

# JPC

11



## Enclosures and accessories for immersion heaters and temperature sensors

- PA66, PP, PVDF, stainless steel enclosures
- Hot forged brass fittings, deep drawn stainless steel fittings
- Stainless steel, titanium pockets and probes
- PA66 connection blocks

**The professional solution:** an extended, rational, and consistent range of products  
**Technical catalogue for R & D department**

**Edition 2018-05-30**

**JPC**

JPC sas, 2 voie Gallo Romaine, ZAC de la Bonne Rencontre, 77860 Quincy Voisins, France  
Tel: +33(0)1 60046644 Fax: +33(0)1 60048444 E-Mail: info@jpcfrance.fr Web: www.jpcfrance.fr

# General Terms of Sales

**GENERAL:** our sales are made under the here below terms of sales. Any contrary conditions provided by the buyer shall not be binding and shall not have any legal effect.

The execution and delivery of any purchase order is made in conformity with the present general terms of sales and it is noted that the buyer first has full knowledge of these terms.

In case of dispute on any of the herein below terms, we will consider ourselves as completely free from any contract related to the execution of any pending order. If some specific conditions are stated by the buyer, these conditions will be considered by us as a formal acceptance only after our written consent.

**ORDER:** we will commit only on orders for which an order acknowledgement has been issued. The sale is regarded executed at the date of order acceptance by JPC. Any cessation or cancellation of pending orders, for whatever reasons, cannot be accepted by JPC without a compensation equal to the ordered goods value.

Any manufactured product being subjected of a prototype or a pre-serie accepted by the customer will be regarded as in compliance with the customer's specifications. No goods can be returned without JPC's written consent. In this case, a credit note valuable on a further purchase order will be issued only if the goods are returned in the original delivery conditions. All manufactured goods made upon a specific order cannot be either returned or be subjected to a credit note.

**PRICES:** our price offers are remitted under the existing conditions at the date of offer, for mentioned quantities. They can be revised after the call period has expired. Orders for lower quantities than quoted: our offers are subjected to price revisions.

Orders with prices related to our general price list can be revised at any time, in accordance to the existing terms at the delivery date. Our prices are VAT exclusive for unpacked materials according to the EXW Incoterm.

For orders less than € 75 Excl. tax exclusive of fees, administrative costs amounting to € 7.62 Excl. tax will be charged to customer.

**DELIVERY TIME:** our delivery times are estimated bona fide. They are purely informative and cannot be considered as commitments. Unless our prior express consent, no overrun will be regarded as a justification of order cancellation or set rights to any compensation or deduction.

**DELIVERY:** Whatever mean of transportation, all risk of loss or damage in transit shall be borne by the purchaser.

The buyer must ensure of the good conditions of the delivered goods and he must make, within the legal terms, all necessary reserves and legal actions in order to preserve his rights against the carrier.

Regarding the conformity and visible quality of delivered goods related to an order, the buyer must send his eventual written claim within an 8 days legal notice from the collection date. Claims will be taken into account only if the goods are kept in the consignment conditions.

For manufacturing reasons, we reserve the right of delivering plus or minus 10 percent of the ordered quantities.

**PAYMENT TERMS:** unless other arrangements expressly provided by special conditions at the bottom of our order acknowledgment, our invoice is resolvable by draft accepted at 30 days end of month .

The invoices less than € 150 Excl. tax, the first order and the files not accepted by our factoring company are resolvable cash on order.

No discount for pre-payment is accepted.

Whatever the mean of payment, we reserve the ability of cancelling or postponing any blanket or purchase order, invoicing any related charges and to ask for an immediate payment of all pending invoices and all implemented collection charges until total settlement has been completed.

In no way, payments due to JPC can be postponed or be subjected to either deduction nor compensation unless JPC's express written consent.

We reserve the right to require an agreed guarantee of the customer's execution of commitments, even during the execution of a blanket or purchase order.

Any refuse from the customer will open JPC's right to partial or total order cancellation.

Any payment to JPC will apply to due amounts whatever the cause, starting with the oldest due amounts.

**RETENTION OF PROPERTY:** our goods are sold with a retention of property.: according to the terms of the 1980/05/12 Law and the 1985/01/25 Law (amended 1994/06/10), the Seller shall keep the ownership of the Products until the full payment of the agreed price is made including any other payments outstanding, if any, from the Purchaser to the Seller. However, the Purchaser shall bear the risk of the loss, damages, harms, deterioration or destruction of the sold Products since such Products are at the disposal of the Purchaser and he must have subscribed any related insurance.

In the event of payment delayed by the Purchaser and 8 days after receipt of a registered reminder letter remained unfruitful, the contract shall be regarded as executed. In such an event, JPC will reserve the right to take back the goods and all related settlements by the Purchaser will not be refunded and regarded as damages, without any restitution or compensation claim from the Purchaser related to an eventual resell.

To prevail over the aforesaid clause and in the event of collective judicial proceedings, JPC will notify its such express will to the Purchaser or to its official representative, by registered letter, to have the goods returned.

**PROPERTY OF TOOLS:** the tools that have been fully settled to JPC are the customer's property. They remain at his entire disposal at JPC's facility if the end product is made by JPC, or in the sub-contractor's French or Foreign facility if the product is sub-contracted or imported.

Unless otherwise written consent from the Purchaser, all tools unused for more than 2 years will be considered as abandoned and will be destroyed. Storage charges can be invoiced if the customer wishes to keep unused tools.

Tools for which a partial amount has been invoiced to the Purchaser remain the property of JPC. The tools are made to fit the manufacturing equipment, Norms or Standards in force at JPC's or at its sub-contractors. Unless otherwise specified, their lifetimes are equal to 3 years life according to the annual quantities provided by the Purchaser during original negotiation or on the original order. In the meantime, all maintenance and repairs charges shall be borne by JPC. For additional quantities than provided, all maintenance and repairs charges shall be borne by the Purchaser.

**WARRANTY:** goods manufactured by JPC are covered by a 1 year warranty coming into force at the delivery date.

For all imported good, our warranty period is limited to the manufacturer's warranty. We cannot be held as responsible for any manufacturing ascertained default on goods re-sold as are. We forward the claims on delivered goods and apply the eventual warranty clauses after agreement receipt from our constituents.

To benefit the warranty, The Purchaser must send a written claim to JPC, providing all ascertained defaults and give JPC all means to ascertain and bring corrective actions.

Packing, freight, return, carriage, un-assembly and re-assembly charges shall be borne by the Purchaser.

**LIABILITY LIMITATIONS:** the buyer must ensure that the use of the purchased products complies with Norms and Rules into force, whatever the advices or recommendations shown in the seller's documents. De facto, he resigns all claims against the Seller. No request for compensations for direct or indirect damages or loss is receivable. JPC's liability is strictly limited to the aforesaid obligations.

**APPROPRIATE COURT – APPLICABLE LAWS:** all sales by JPC are subjected to French Laws including the 1980 Vienna Convention on International Sales. Any controversy, dispute or claim arising out of or related to this contract or breach thereof shall be settled by arbitration of The Tribunal de Commerce Court held in Meaux, 77, France.

JPC sas- 2 voie Gallo-Romaine - ZAC de la Bonne Rencontre - 77860 Quincy Voisins - France

RCS Meaux 302 236 641 00049 – APE 2651B - FR10 302 236 641

## Summary



### Technical introduction





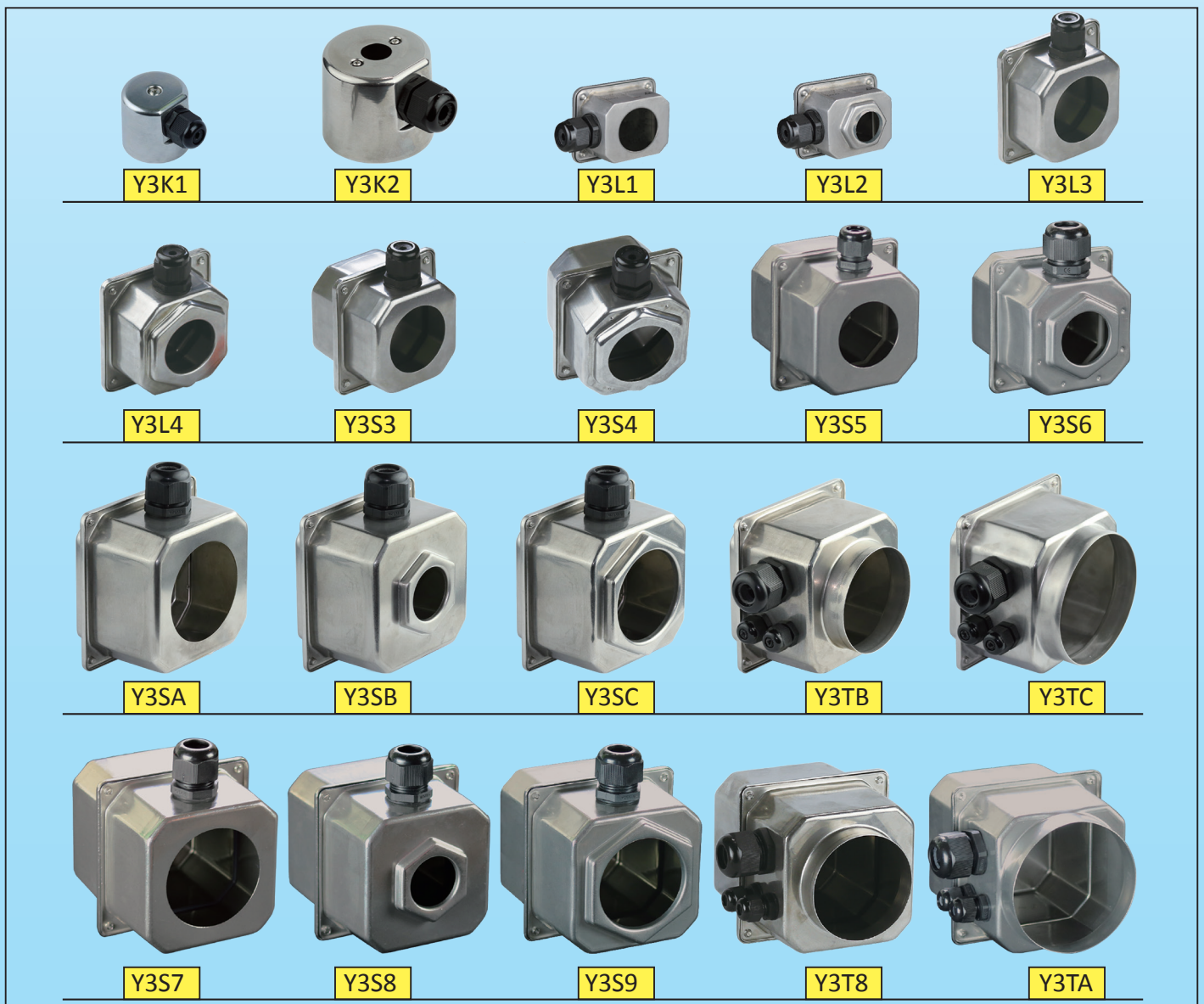







IP protection grades	P25-32
Electric protection	P33-36
Impact protection	P37-42
Corrosion protection of aluminum	P43-46
Stainless steel	P47-50
Characteristics of plastics	P51-58
Surface finish of aluminum and stainless steel	P59-62
Connection blocks	P63-66
Immersion heaters fittings	P67-71
Main drill used in temperature sensors and immersion heater enclosures	P72
Access devices for adjustment or reset	P73-78
Examples of assembly of various products inside enclosures	P79-82













### Summary of deep drawn enclosures for average corrosion conditions, AISI 304 or AISI 316 stainless steel



Because of permanent improvement of our products, drawings, descriptions, features used on these data sheets are for guidance only and can be modified without prior advice

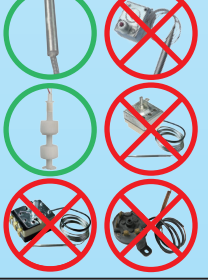

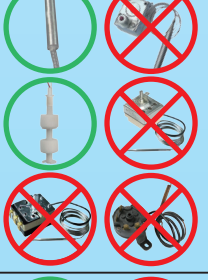

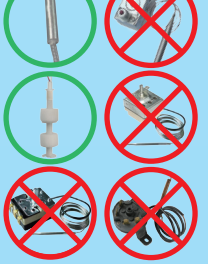









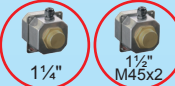

# Summary of deep drawn enclosures for average corrosion conditions, AISI 304 or AISI 316 stainless steel

Logo chart explanation	 Single pole bulb and capillary thermostat	 Manual reset 3 pole bulb and capillary limiter	 Digital display electronic temperature controller, 77x35mm	 Level float switch	 Electro-mechanical power contactor
	 Manual reset single pole bulb and capillary limiter	 Electronic thermostat or limiter, knob adjustment	 Digital display electronic temperature controller, 48x48mm	 Single pole solid state relay	
	 3 pole bulb and capillary thermostat	 Temperature sensor probe	 Din rail mounting 47x52mm digital display temperature controller	 3 pole solid state relay	

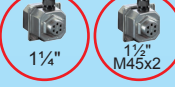
Type	Compatibility with fittings	Sizes without cable gland	IP, IK	Features	Compatibility with controls	Page
Y3K1	 	Dia. 54 x 50 mm (105cm <sup>3</sup> , 74g)	IP69K, IK7	<b>Round miniature simplified immersion heater enclosure</b> - Mounting on single thread brass or stainless steel fittings 1"1/4, 1"1/2 and M45x2, but also on fittings with <b>M4 centre thread</b> - Output by M20 cable gland		85
Y3K2	 	Dia. 86 x 72 mm (390 cm <sup>3</sup> , 180g)	IP69K, IK7	<b>Round, large diameter, simplified immersion heater enclosure</b> - Mounting with an internal bracket on single thread brass or stainless steel fittings, 2"1/2 and M45x2 - Output by M25 cable gland		86
Y3L1	 	75 x 60 x 44 mm (111cm <sup>3</sup> , 137g)	IP69K, IK7	<b>Miniature enclosure for temperature sensor or level sensor</b> - Flat lid - Bottom side without hole or with hole for fitting - Hole for M20 cable gland		87
Y3L2	 	75 x 60 x 52 mm (119cm <sup>3</sup> , 146g)	IP69K, IK7	<b>Miniature enclosure for temperature sensor or level sensor</b> - Flat lid - Bottom side with stamped hexagon 35mm on flat, for TIG welded 1/2" or 3/4" fittings - Hole for M20 cable gland		88
Y3L3	 	90 x 90 x 45 mm (206cm <sup>3</sup> , 198g)	IP69K, IK7	<b>Miniature enclosure for immersion heater, temperature sensor or level sensor</b> - Flat lid - Bottom side without hole, or with hole for orientable fitting with ring or inside nut - Hole for M20 cable gland		89









Because of permanent improvement of our products, drawings, descriptions, features used on these data sheets are for guidance only and can be modified without prior advice

# Summary of deep drawn enclosures for average corrosion conditions, AISI 304 or AISI 316 stainless steel

Type	Compatibility with fittings	Sizes without cable gland	IP, IK	Features	Compatibility with controls	Page
Y3L4	 	90 x 90 x 52 mm (232cm <sup>3</sup> , 207g)	IP69K, IK7	<b>Enclosure for small storage heater immersion heater</b> - Flat lid - Bottom side with stamped 61mm hexagon, can be used on orientable fitting with ring or inside nut - Hole for M20 cable gland - Can receive a standard storage heater immersion heater, with 1/1/4 brass fitting, with 54 mm on flat hexagon		90
Y3S3	 	90 x 90 x 75 mm (392cm <sup>3</sup> , 262g)	IP69K, IK7	<b>Immersion heater or temperature sensor enclosure</b> - High lid - Bottom side without hole, or with hole for orientable fitting with ring or internal nut - Hole for M20 cable gland		91
Y3S4	 	90 x 90 x 82 mm (418cm <sup>3</sup> , 271g)	IP69K, IK7	<b>Immersion heater enclosure with built-in hexagon for fitting</b> - High lid - Bottom side with stamped 61mm hexagon, can be used on orientable fitting with ring or inside nut - Can be used with 1 1/4 or 1 1/2 or M45 TIG welded fittings - Hole for M20 cable gland - Can receive a standard storage heater immersion heater, with 1/1/4 brass fitting, with 54mm on flat hexagon		92
Y3S5	 	105 x 105 x 102 mm (757cm <sup>3</sup> , 420g)	IP69K, IK7	<b>Medium size enclosure for immersion heater or temperature sensor</b> - Bottom side without hole, or with hole for orientable fitting with ring or internal nut up to 2 1/2 - Fits the 2" plastic nut for swimming pools, spas and aquarium heaters and electronic thermostat control - Hole for M25 cable gland		93
Y3S6	 	105 x 105 x 110 mm (781cm <sup>3</sup> , 426g)	IP69K, IK7	<b>Medium size immersion heater enclosure with built-in hexagon for fitting</b> - Bottom side with stamped hexagon 58mm on flat, for 1 1/4 or 1 1/2 or M45 TIG welded fittings - Hole for M25 cable gland		94
Y3SA	 	125 x 125 x 85 mm (970cm <sup>3</sup> , 610g)	IP69K, IK7	<b>Immersion heater or temperature sensor, flat cover</b> - Bottom side without hole, or with hole for orientable fitting with ring or internal nut, up to M77 or 2 1/2 - Fits the 2" plastic nut for swimming pools, spas and aquarium heaters and electronic thermostat control and electronic manual reset thermostat - Hole for one M25 cable gland, or holes for one M25 and two M16 - Optional hole for pilot light		95





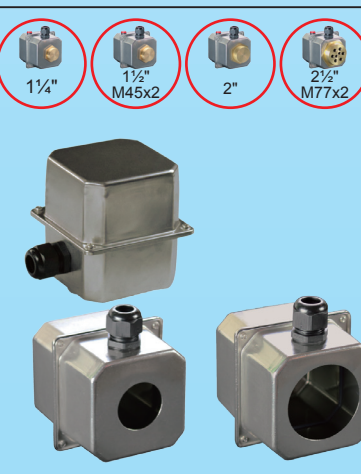
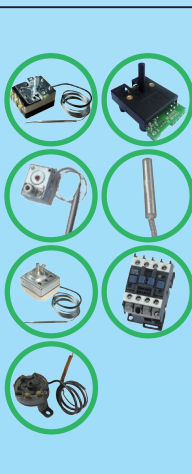

Because of permanent improvement of our products, drawings, descriptions, features used on these data sheets are for guidance only and can be modified without prior advice

# Summary of deep drawn enclosures for average corrosion conditions, AISI 304 or AISI 316 stainless steel

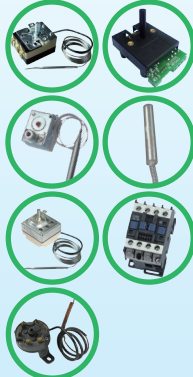
Type	Compatibility with fittings	Sizes without cable gland	IP, IK	Features	Compatibility with controls	Page
Y3SB		125 x 125 x 93 mm (1000cm <sup>3</sup> , 624g)	IP69K, IK7	<b>Big immersion heater enclosure, with flat cover and stamped hexagon</b> - Bottom side with stamped 58mm on flat hexagon, for 1 "1/4, 1 "1/2 or M45 TIG welded fittings - Hole for one M25 cable gland, or holes for one M25 and two M16 - <b>Optional hole for pilot light</b>		96
Y3SC		125 x 125 x 85 mm (1000cm <sup>3</sup> , 610g)	IP69K, IK7	<b>Big immersion heater enclosure, with flat cover and stamped hexagon, for big immersion heaters</b> - Bottom side with stamped 85mm on flat hexagon, for 2 "1/2 or M77 TIG welded fittings - Hole for one M25 cable gland, or holes for one M25 and two M16 - <b>Optional hole for pilot light</b>		97
Y3TB		125 x 125 x 105 mm (1138cm <sup>3</sup> , 489g)	IP69K, IK7	<b>Big enclosure, for immersion heaters or instruments, with flat cover, for welding on tubes</b> - Bottom side with stamped hole with welding lips for direct welding on in line heaters body or on dia. 80mm tubes. - Hole for one M25 cable gland, or holes for one M25 and two M16 - <b>Optional hole for pilot light</b>		98
Y3TC		125 x 125 x 105 mm (1138cm <sup>3</sup> , 489g)	IP69K, IK7	<b>Big enclosure, for immersion heaters or instruments, with flat cover for welding on tubes</b> - Bottom side with stamped hole with welding lips for direct welding on in line heaters body or on dia. 100mm tubes. - Hole for one M25 cable gland, or holes for one M25 and two M16 - <b>Optional hole for pilot light</b>		99
Y3S7		125 x 125 x 130 mm (1505cm <sup>3</sup> , 652g)	IP69K, IK7	<b>Big size enclosure for immersion heater or temperature sensor</b> - Bottom side without hole, or with hole for orientable fitting with ring or internal nut, up to M77 or 2 "1/2 - Fits the 2" plastic nut for swimming pools, spas and aquarium heaters and electronic thermostat control and electronic manual reset thermostat - Hole for one M25 cable gland, or holes for one M25 and two M16 - <b>Optional hole for pilot light</b> - <b>Can receive one or two power relays</b>		100

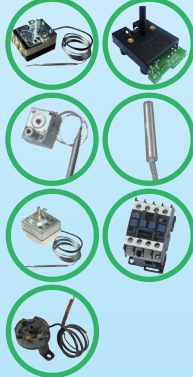
Because of permanent improvement of our products, drawings, descriptions, features used on these data sheets are for guidance only and can be modified without prior advice

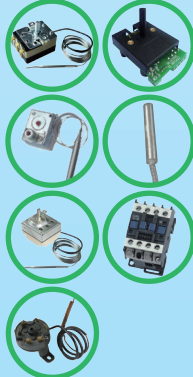
# Summary of deep drawn enclosures for average corrosion conditions, AISI 304 or AISI 316 stainless steel

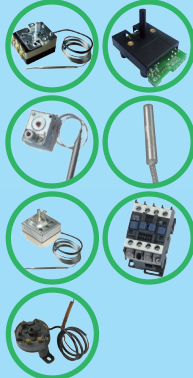
Type	Compatibility with fittings	Sizes without cable gland	IP, IK	Features	Compatibility with controls	Page
Y3S8		125 x 125 x 138 mm (1525cm <sup>3</sup> , 656g)	IP69K, IK7	<p><b>Big size enclosure for immersion heater with built-in hexagon</b></p> <ul style="list-style-type: none"> <li>- Bottom side with stamped 58mm on flat hexagon, for 1 "1/4, 1 "1/2 or M45 TIG welded fittings</li> <li>- Hole for one M25 cable gland, or holes for one M25 and two M16</li> <li>- <b>Optional hole for pilot light</b></li> <li>- <b>Can receive one or two power relays</b></li> </ul>		101
Y3S9		125 x 125 x 138 mm (1551cm <sup>3</sup> , 643g)	IP69K, IK7	<p><b>Big size enclosure with built in hexagon for large size immersion heaters</b></p> <ul style="list-style-type: none"> <li>- Bottom side with stamped 85mm on flat hexagon, for 2 "1/2 or M77 TIG welded fittings</li> <li>- Hole for one M25 cable gland, or holes for one M25 and two M16</li> <li>- <b>Optional hole for pilot light</b></li> <li>- <b>Can receive one or two power relays</b></li> </ul>		102
Y3T8		125 x 125 x 135 mm (1668cm <sup>3</sup> , 634g)	IP69K, IK7	<p><b>Big size immersion heater or controls enclosure, for direct welding on pipes</b></p> <ul style="list-style-type: none"> <li>- Bottom side with stamped hole with welding lips for direct welding on in line heaters body or on dia. 80 or 100mm tubes.</li> <li>- Hole for one M25 cable gland, or holes for one M25 and two M16</li> <li>- <b>Optional hole for pilot light</b></li> <li>- <b>Can receive one or two power relays</b></li> </ul>		103
Y3TA		125 x 125 x 135 mm (1668cm <sup>3</sup> , 634g)	IP69K, IK7	<p><b>Big size immersion heater or controls enclosure, for direct welding on pipes</b></p> <ul style="list-style-type: none"> <li>- Bottom side with stamped hole with welding lips for direct welding on in line heaters body or on dia. 100mm tubes.</li> <li>- Hole for one M25 cable gland, or holes for one M25 and two M16</li> <li>- <b>Optional hole for pilot light</b></li> <li>- <b>Can receive one or two power relays</b></li> </ul>		104

Because of permanent improvement of our products, drawings, descriptions, features used on these data sheets are for guidance only and can be modified without prior advice

## Summary

# Enclosures for immersion heaters and temperature sensors in PA66 and PC for industrial environment



<b>Logo chart explanation</b>		Single pole bulb and capillary thermostat		Manual reset 3 pole bulb and capillary limiter		Digital display electronic temperature controller, 77x35mm		Level float switch	 Electro-mechanical power contactor
		Manual reset single pole bulb and capillary limiter		Electronic thermostat or limiter, knob adjustment		Digital display electronic temperature controller, 48x48mm		Single pole solid state relay	
		3 pole bulb and capillary thermostat		Temperature sensor probe		Din rail mounting 47x52mm digital display temperature controller		3 pole solid state relay	











Type	Pictures	Sizes	IP, IK	Features	Compatible	Page
Y3A1		61 x 33 x 30 mm (52cm <sup>3</sup> , 30g)	IPX4, IK8	<b>Sub-miniature enclosure for temperature sensor, level sensor, electronic printed circuit or cartridge heater</b> - Can receive a drill up to 21 mm (1/2 ") for sensor rod outlet - Includes mounting bosses for PCBs - Includes a removable 3-way 2.5mm <sup>2</sup> terminal block in the version with M16 cable gland output - Output via M12 connector, Cnomo connector or M16 cable gland		107
Y3A2		70 x 33 x 33 mm (72cm <sup>3</sup> , 37g)	IPX4, IK8	<b>Sub-miniature enclosure for temperature sensor, level sensor, electronic printed circuit or cartridge heater</b> - Includes a moulded pilot light lens - Can receive a drill up to 21 mm (1/2 ") for sensor rod outlet - Includes mounting bosses for PCBs - Includes a removable 3-way 2.5mm <sup>2</sup> terminal block in the version with M16 cable gland output - Output via M12 connector, Cnomo connector or M16 cable gland		108

Because of permanent improvement of our products, drawings, descriptions, features used on these data sheets are for guidance only and can be modified without prior advice



## Summary









# Enclosures for immersion heaters and temperature sensors in PA66 and PC for industrial environment

Type	Pictures	Sizes	IP, IK	Features	Compatible	Page
Y3A3		100 x 56 x 37 mm (208cm <sup>3</sup> , 80g)	IP69K, IK10	<b>Miniature enclosure for temperature sensor, level sensor, electronic printed circuit or cartridge heater</b> - Includes two removable brackets for wall mounting - Can receive a drill up to 21 mm (1/2 ") for sensor rod outlet - Includes mounting bosses for PCBs - Includes a removable 5-way 2.5mm <sup>2</sup> terminal block - Output via M20 cable gland		109
Y3A4		100 x 56 x 48 mm (216cm <sup>3</sup> , 89g)	IP69K, IK10	<b>Miniature enclosure for temperature sensor, level sensor, electronic printed circuit or cartridge heater</b> - Includes two removable brackets for wall mounting - Can receive a drill up to 21 mm (1/2 ") for sensor rod outlet - Includes mounting bosses for PCBs - Can eventually receive a removable 5-way 2.5mm <sup>2</sup> terminal block - Output via an IP66 M21 connector, 2 to 5 ways		110
Y301		48 x 48 x 41 mm (93cm <sup>3</sup> , 32g)	IPX5, IK8	<b>Miniature enclosure for temperature sensor, level sensor, electronic printed circuit or cartridge heater</b> - Can accommodate 1/2" threaded fittings with internal lock nut or 3/4" or 1" brass fittings with 2 x M4 screws (Use a flat gasket) - Includes a removable internal 3-way 2.5mm <sup>2</sup> terminal block - PG11 cable gland outlet		111
Y302		Dia. 54 x 66 mm (160cm <sup>3</sup> , 26g)	IP69K, IK8	<b>Simplified immersion heater enclosure for fittings with M4 central screw</b> - Mounting on brass fittings 1 "1/4, 1" 1/2 and M45x2 - Output by M20 cable gland		112
Y3C1		Dia. 54 x 74 mm (180cm <sup>3</sup> , 70g)	IP69K, IK8	<b>Immersion heater enclosure for standard fittings with three M4 mounting screws at 120°</b> - For 1 "1/4, 1" 1/2 and M45x2 fittings - Features a removable, elevated, 6-way 2.5mm <sup>2</sup> terminal block - Output by M20 cable gland		113

Because of permanent improvement of our products, drawings, descriptions, features used on these data sheets are for guidance only and can be modified without prior advice

## Summary

# Enclosures for immersion heaters and temperature sensors in PA66 and PC for industrial environment

Type	Pictures	Sizes	IP, IK	Features	Compatible	Page
Y3C2		Dia. 65x 66 mm (200cm <sup>3</sup> , 33.7g)	IP69K, IK8	<b>Miniature Enclosure for 2" fittings</b> <b>- Fits the 2" plastic fitting for spas and swimming pools heaters</b> using cartridge heaters diameter 25mm, stainless steel or titanium - Clamping of the tube by silicone or Viton (FKM) compression seal - The 2 " thread and the swivel nut allow attachment to spa heaters, pool or flange heaters, or 2" PVC hoses used on surface treatment baths - Includes a removable 6-way 2.5mm <sup>2</sup> terminal block - Main output by M20 cable gland - M12 connector, 4 ways, auxiliary output is in option for temperature sensor		114
Y3C3		Dia. 86x 75 mm (416cm <sup>3</sup> , 55g)	IP69K, IK9	<b>Simplified round enclosure for 2"1/2 and M77x2 fittings.</b> <b>Fits all fittings with 3 screws M5 for rotation ring.</b> <b>Main output by M25 cable gland</b>		115
Y3B1		105 x 88 x 58.5 mm (550cm <sup>3</sup> , 170g)	IP69K, IK10	<b>Temperature sensor, thermostat or level sensor enclosure</b> - The lid includes a moulded pilot light lens - Includes 2 removable wall mounting brackets - Can receive a hole on the backside for probe - Features a sealed system for lateral sensor cable exit - Optional sensor pocket bracket - Output by one or two M20 cable glands		116
Y3B2		105 x 88 x 84.5 mm (633cm <sup>3</sup> , 200g)	IP69K, IK10	<b>Immersion heater housing for commercial water heater tanks</b> - Extension on the back for mounting 1"1/4, 1"1/2 and M45x2 immersion heaters fittings with double thread and internal nut, or single thread with rotating ring - The lid includes a moulded pilot light lens - Can be fitted with one or two watertight screwed caps on the lid allowing access to internal settings - Output by one or two M20 cable glands		117

Because of permanent improvement of our products, drawings, descriptions, features used on these data sheets are for guidance only and can be modified without prior advice

## Summary

# Enclosures for immersion heaters and temperature sensors in PA66 and PC for industrial environment

Type	Pictures	Sizes	IP, IK	Features	Compatible	Page
Y306		Dia. 100 x 100 mm (700cm <sup>3</sup> , 168g)	IP69K, IK10	<p><b>Round enclosure for immersion heater or temperature sensor</b></p> <ul style="list-style-type: none"> <li>- Drilling on the bottom possible for probes, or immersion heater fittings</li> <li>- Can receive a boot or a M20 thread on the lid for access to internal adjustment</li> <li>- Features bosses for internal bracket</li> <li>- Admits double threaded or rotating ring fittings up to 2 "</li> <li>- Cable outlet up to M25 (2 cable glands possible)</li> </ul>		118
Y3C4		Dia. 100 x 125 mm (783cm <sup>3</sup> , 200g)	IP69K, IK10	<p><b>Round enclosure for immersion heater or temperature sensor with extension</b></p> <ul style="list-style-type: none"> <li>- Drilling on the bottom possible for probes, or immersion heater fittings</li> <li>- Can receive a boot or a M20 thread on the lid for access to internal adjustment</li> <li>- Features bosses for internal bracket</li> <li>- Extension on the rear side for mounting, for 1"1/4, 1"1/2 and M45x2 immersion heaters fittings with double thread and internal nut, or single thread with rotating ring</li> <li>- Cable outlet up to M25 (2 cable glands possible)</li> </ul>		120
Y3F1		Dia. 105 x 66 mm (500cm <sup>3</sup> , 225g)	IP69K, IK10	<p><b>Wall mounting temperature sensor enclosure</b></p> <ul style="list-style-type: none"> <li>- Transparent polycarbonate cover</li> <li>- Features a sealed sensor cable exit system at the top</li> <li>- Includes mounting bosses for printed circuit boards</li> <li>- Includes mounting holes for a 4-20mA temperature converter</li> <li>- Includes two wall brackets</li> <li>- Includes a removable 2.5mm<sup>2</sup> 6-way terminal block</li> <li>- Output by two M20 cable glands</li> </ul>		121

Because of permanent improvement of our products, drawings, descriptions, features used on these data sheets are for guidance only and can be modified without prior advice

## Summary









# Enclosures for immersion heaters and temperature sensors in PA66 and PC for industrial environment

Type	Pictures	Sizes	IP, IK	Features	Compatible	Page
Y3F2		Dia. 105 x 66 mm (500cm <sup>3</sup> , 220g)	IP69K, IK10	<p><b>Immersion heater, level sensor or temperature sensor enclosure</b></p> <ul style="list-style-type: none"> <li>- Transparent polycarbonate cover.</li> <li>- Includes two brackets for mounting on tank edge board.</li> <li>- Drilling of different diameters possible on the back for direct probes or for 1" 1/4, 1" 1/2 and M45x2 immersion heaters with double thread and internal nut, or single thread with rotating ring.</li> <li>- Includes a removable 6-way 2.5mm<sup>2</sup> terminal block.</li> <li>- Output by two M20 cable glands</li> </ul>		122
Y3F3		Dia. 105 x 87 mm (583cm <sup>3</sup> , 255g)	IP69K, IK10	<p><b>Immersion heater enclosure with extension</b></p> <ul style="list-style-type: none"> <li>- Transparent polycarbonate cover</li> <li>- Includes two wall brackets</li> <li>- Extension on the back for 1" 1/4, 1" 1/2 and M45x2 immersion heaters with double thread and internal nut, or single thread with rotating ring</li> <li>- Removable 6-way terminal block</li> <li>- Output by two M20 cable glands</li> </ul>		123
Y307		130 x 130 x 150 mm (2530cm <sup>3</sup> , 515g)	IP69K, IK10	<p><b>Big size enclosure for immersion heater, temperature sensor, level sensor or controls</b></p> <ul style="list-style-type: none"> <li>- Can receive one or more waterproof boots or screwed caps on the lid, allowing access to internal adjustment</li> <li>- The cover can also receive multiple holes for pilot lights, switches, etc</li> <li>- Can receive one or two power contactors on internal Din rail</li> <li>- Features bosses and slides for PCBs</li> <li>- Backside can receive drills for temperature sensor probes, level sensor or immersion heater fittings, up to M77x2</li> <li>- Internal removable connection block (up to 12 ways, 2.5, 6 and 10mm<sup>2</sup>)</li> <li>- Several models of cable gland plate holder, with many possibilities, including for flat cables, from 1 to 4 outlets, size up to M25</li> </ul>		124

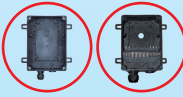
Because of permanent improvement of our products, drawings, descriptions, features used on these data sheets are for guidance only and can be modified without prior advice

## Summary

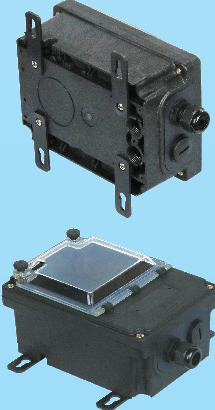
# Enclosures for immersion heaters and temperature sensors in PA66 and PC for industrial environment

Type	Pictures	Sizes	IP, IK	Features	Compatible	Page
Y3M1	 	130 x 130 x 190 mm (2836cm <sup>3</sup> , 650g)	IP69K, IK10	<p><b>Big size enclosure with extension, for immersion heater</b></p> <ul style="list-style-type: none"> <li>- Can accommodate 1"1/4, 1"1/2, M45x2, 2", 2"1/2, and M77x2 double thread and internal nut fittings, or single thread with rotation ring</li> <li>- Can receive one or more waterproof boots or screwed caps on the lid, allowing access to internal adjustment</li> <li>- The cover can also receive multiple holes for pilot lights, switches, etc</li> <li>- Can receive one or two power contactors on internal Din rail</li> <li>- Features bosses and slides for PCBs</li> <li>- Internal removable connection block (up to 12 ways, 2.5, 6 and 10mm<sup>2</sup>)</li> <li>- Several models of cable gland plate holder, with many possibilities, including for flat cables, from 1 to 4 outlets, size up to M25</li> </ul>		126
Y3N1	 	130 x 180 x 80 mm (1870cm <sup>3</sup> , 1150g)	IP69K, IK10	<p><b>Enclosure for controls, connection, temperature sensor, thermostat, level sensor. Removable wall mounting legs</b></p> <ul style="list-style-type: none"> <li>- Black polycarbonate cover</li> <li>- Includes 4 removable wall brackets</li> <li>- Possibility of PCBs assembly</li> <li>- Can receive a hole on the back side for temperature sensor probe, thermostat rod or level detector probe</li> <li>- Several models of removable internal terminal blocks are available (up to 12 channels, 2.5, 6 and 10mm<sup>2</sup>)</li> <li>- Several models of cable gland plate holder, with many possibilities, including for flat cables, from 1 to 4 outlets, up to M25</li> </ul>		128
Y3N2	 	130 x 180 x 95 mm (2010cm <sup>3</sup> , 1200g)	IP69K, IK10	<p><b>Enclosure with window, for controls, connection, temperature sensor, thermostat, level sensor, GFCI</b></p> <ul style="list-style-type: none"> <li>- Front panel with hinged polycarbonate porthole</li> <li>- Includes 4 removable wall brackets</li> <li>- Possibility of PCBs assembly</li> <li>- Can receive a hole on the back side for temperature sensor probe, thermostat rod or level detector probe</li> <li>- Several models of removable internal terminal blocks are available (up to 12 channels, 2.5, 6 and 10mm<sup>2</sup>)</li> <li>- Several models of cable gland plate holder, with many possibilities, including for flat cables, from 1 to 4 outlets, up to M25</li> </ul>		129

Because of permanent improvement of our products, drawings, descriptions, features used on these data sheets are for guidance only and can be modified without prior advice

## Summary

# Enclosures for immersion heaters and temperature sensors in PA66 and PC for industrial environment

Type	Pictures	Sizes	IP, IK	Features	Compatible	Page
Y3N3		130 x 180 x 120 mm (2093cm <sup>3</sup> , 1230g)	IP69K, IK10	<p><b>Enclosure with window for immersion heaters, with extension</b></p> <ul style="list-style-type: none"> <li>- Extension on the back for 1 "1/4, 1" 1/2 and M45x2 immersion heaters with double thread and internal nut, or single thread with rotating ring</li> <li>- Front panel with hinged polycarbonate porthole</li> <li>- Several models of removable internal terminal blocks are available (up to 12 channels, 2.5, 6 and 10mm<sup>2</sup>)</li> <li>- Several models of cable gland plate holder, with many possibilities, including for flat cables, from 1 to 4 outlets, up to M25</li> </ul>		130
Y3N4		130 x 180 x 132 mm (2580cm <sup>3</sup> , 1650g)	IP69K, IK10	<p><b>Enclosure with window, for immersion heater with electronic temperature control with heat sink for solid state relay (SSR)</b></p> <ul style="list-style-type: none"> <li>- Aluminum extension on rear side with heat exchanger, allows the assembly of static relays</li> <li>- Extension on the back accepts 1 "1/4, 1" 1/2 and M45x2 immersion heaters with double thread and internal nut, or single thread with rotating ring</li> <li>- Front panel with hinged polycarbonate porthole</li> <li>- Several models of removable internal terminal blocks are available (up to 12 channels, 2.5, 6 and 10mm<sup>2</sup>)</li> <li>- Several models of cable gland plate holder, with many possibilities, including for flat cables, from 1 to 4 outlets, up to M25</li> </ul>		131

Because of permanent improvement of our products, drawings, descriptions, features used on these data sheets are for guidance only and can be modified without prior advice

# Summary

## Immersion heaters and temperature sensors enclosures for highly corrosive environments



Y3C6



Y3C7

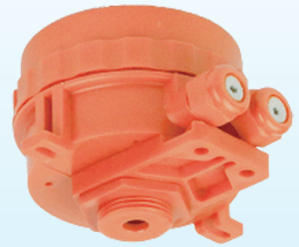

Y3C8



Y3E6



Y3E7



Y3E8









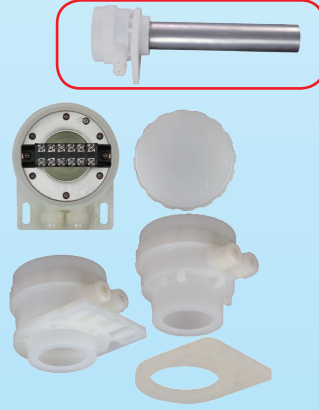

Logo chart explanation		Single pole bulb and capillary thermostat		Manual reset 3 pole bulb and capillary limiter		Digital display electronic temperature controller, 77x35mm		Level float switch		Electro-mechanical power contactor
		Manual reset single pole bulb and capillary limiter		Electronic thermostat or limiter, knob adjustment		Digital display electronic temperature controller, 48x48mm		Single pole solid state relay		
		3 pole bulb and capillary thermostat		Temperature sensor probe		Din rail mounting 47x52mm digital display temperature controller		3 pole solid state relay		

Type	Pictures	Sizes without cable gland	Material, IP, IK	Features	Compatible	Page
Y3C6		Dia. 105 x 95 mm (663cm <sup>3</sup> , 174g)	 Corrosive environments IP69K, IK10	<b>Polypropylene immersion heater enclosure for surface treatment baths and highly corrosive environments</b> - Viton gasket system for immersion heater pocket with steatite heating element - 2 integrated M20 cable glands with Viton gaskets - Removable polypropylene plate for mounting at the edge of tank - Titanium external screws - Removable 6-way terminal block		132
Y3C7	 	Dia. 105 x 95 mm (663cm <sup>3</sup> , 174g)	 Corrosive environments IP69K, IK10	<b>Polypropylene immersion heater enclosure for surface treatment baths and highly corrosive, environments</b> - Compatible with conventional 1 "1/4, 1" 1/2, M45 double thread or rotating ring couplings - 2 integrated M20 cable glands with Viton gaskets - Removable polypropylene plate for mounting at the edge of tank - Titanium external screws - Removable 6-way terminal block		133

Because of permanent improvement of our products, drawings, descriptions, features used on these data sheets are for guidance only and can be modified without prior advice

## Summary

# Immersion heaters and temperature sensors enclosures for **highly corrosive environments**

Type	Pictures	Sizes without cable gland	Material, IP, IK	Features	Compatible	Page
Y3C8		Dia. 105 x 82 mm (525cm <sup>3</sup> , 159g)	 <b>Corrosive environments</b> <b>IP69K, IK10</b>	<b>Polypropylene temperature sensor enclosure for surface treatment baths and highly corrosive environments</b> - Built-in 1" thread, with lock nut and mounting plate - Viton seal system for temperature sensor tube, thermostat, or level sensor - Polypropylene 1" nut and plate for mounting to the edge of tank - 2 integrated M20 cable glands with Viton gaskets - Removable 6-way terminal block		134
Y3E6		Dia. 105 x 95 mm (663cm <sup>3</sup> , 310g)	 <b>highly corrosive environments</b> <b>IP69K, IK10</b>	<b>PVDF immersion heater enclosure for surface treatment baths and highly corrosive environments</b> - Viton gasket system for immersion heater pocket with steatite heating element - 2 integrated M20 cable glands with Viton gaskets - Removable PVDF plate for mounting at the edge of tank - Titanium external screws - Removable 6-way terminal block		135
Y3E7		Dia. 105 x 95 mm (663cm <sup>3</sup> , 310g)	 <b>highly corrosive environments</b> <b>IP69K, IK10</b>	<b>PVDF immersion heater enclosure for surface treatment baths and highly corrosive environments</b> - Compatible with conventional 1" 1/4, 1" 1/2, M45 double thread or rotating ring couplings - 2 integrated M20 cable glands with Viton gaskets - Removable PVDF plate for mounting at the edge of tank - Titanium external screws - Removable 6-way terminal block		136
Y3E8		Dia. 105 x 82 mm (525cm <sup>3</sup> , 284g)	 <b>highly corrosive environments</b> <b>IP69K, IK10</b>	<b>PVDF temperature sensor enclosure for surface treatment baths and highly corrosive environments</b> - Built-in 1" thread, with lock nut and mounting plate - Viton seal system for temperature sensor tube, thermostat, or level sensor - PVDF 1" nut and plate for mounting to the edge of tank - 2 integrated M20 cable glands with Viton gaskets - Removable 6-way terminal block		137

Because of permanent improvement of our products, drawings, descriptions, features used on these data sheets are for guidance only and can be modified without prior advice



## Summary

# Die cast immersion heaters aluminum enclosures, for industrial applications requesting the highest shock resistance



Y303



Y304



Y305



Y3P1



Y3P3



Y3P4



Y3P5



Y3P6



Y3H1



Y3H2



Y3H3



Y3G1



Y3G2



Y309



Y3J1



Y3J2



Y310

















Logo chart explanation		Single pole bulb and capillary thermostat		Manual reset 3 pole bulb and capillary limiter		Digital display electronic temperature controller, 77x35mm		Level float switch		Electro-mechanical power contactor
		Manual reset single pole bulb and capillary limiter		Electronic thermostat or limiter, knob adjustment		Digital display electronic temperature controller, 48x48mm		Single pole solid state relay		
		3 pole bulb and capillary thermostat		Temperature sensor probe		Din rail mounting 47x52mm digital display temperature controller		3 pole solid state relay		

Type	Pictures	Sizes without cable gland	IP, IK	Features	Fits thermostat or limiter	Page
Y303		78 x 66 x 50 mm (210cm <sup>3</sup> , 180g)	IP69K, IK10	<b>Miniature enclosure for immersion heater, level sensor or temperature sensor</b> - Can receive a drill on the back side for immersion heater fitting up to 1"1/2 (double threaded model, only with case tapping) - Can receive a drill on the back side for temperature sensor or level sensor - Output by M20 cable gland		141

Because of permanent improvement of our products, drawings, descriptions, features used on these data sheets are for guidance only and can be modified without prior advice

## Summary

# Die cast immersion heaters aluminum enclosures, for industrial applications requesting the highest shock resistance

Type	Pictures	Sizes without cable gland	IP, IK	Features	Fits thermostat or limiter	Page
Y304	 	78 x 78 x 74 mm (410cm <sup>3</sup> , 270g)	IP69K, IK10	<p><b>Enclosure for immersion heater, level sensor or temperature sensor</b></p> <ul style="list-style-type: none"> <li>- Can receive a drill on the back for 1"1/4, 1"1/2 and M45x2 fittings with double thread and inner nut, or single thread with rotating ring</li> <li>- Can receive a 2" double thread fitting (only with thread on the enclosure)</li> <li>- Can receive a drill on the back for temperature sensor or level sensor</li> <li>- Has mounting bosses for internal adjustment backplate</li> <li>- Available in lightened version with reduced wall thickness to 1.7mm instead of 3mm</li> <li>- Output by cable gland M20 or M25</li> </ul>	 	143
Y305	 	105 x 105 x 96 mm (858cm <sup>3</sup> , 490g)	IP69K, IK10	<p><b>Enclosure for immersion heater</b></p> <ul style="list-style-type: none"> <li>- Can receive a drill on the back side for 1"1/4, 1"1/2 and M45x2 fittings with double thread and inner nut, or single thread with rotating ring</li> <li>- Can also accommodate a 2" double threaded fitting (only with threaded ring)</li> <li>- Has mounting bosses for internal adjustment backplate</li> <li>- Output via an M20 or M25 cable gland</li> </ul>	 	145
Y3P1	 	64 x 84 x 104 mm (510cm <sup>3</sup> , 326g)	IP69K, IK10	<p><b>Small size enclosure for immersion heater, finned heaters or controls</b></p> <ul style="list-style-type: none"> <li>- Can receive backside holes for 1"1/4, 1"1/2 and M45x2 fittings with double thread and inner nut, or single thread with rotating ring</li> <li>- Can also receive back side holes for finned heating elements</li> <li>- Output by one or two M20 or M25 cable glands</li> </ul>	 	147
Y3P3	 	66 x 89 x 114 mm (650cm <sup>3</sup> , 417g)	IP69K, IK10	<p><b>Medium size enclosure for immersion heater, finned heaters or controls</b></p> <ul style="list-style-type: none"> <li>- Can receive backside holes for 1"1/4, 1"1/2, M45x2, fittings with double thread and inner nut, or single thread with rotating ring</li> <li>- Can accommodate stainless steel wall mounting brackets</li> <li>- Output by one or two M20 or M25 cable glands</li> </ul>	 	149

Because of permanent improvement of our products, drawings, descriptions, features used on these data sheets are for guidance only and can be modified without prior advice

## Summary

# Die cast immersion heaters aluminum enclosures, for industrial applications requesting the highest shock resistance

Type	Pictures	Sizes without cable gland	IP, IK	Features	Fits thermostat or limiter	Page
Y3P4		110 x 110 x 70 mm (725cm <sup>3</sup> , 342g)	IP69K, IK10	<p><b>Medium size enclosure for immersion heater, finned heaters with external adjustment knob</b></p> <ul style="list-style-type: none"> <li>- Cover has deep recess for protected external knob, access from front or side of cover</li> <li>- Can receive backside holes for 1"1/4, 1"1/2, M45x2, fittings with double thread and inner nut, or single thread with rotating ring</li> <li>- Can accommodate wall mounting brackets</li> <li>- Can also receive back side holes for finned heating elements</li> <li>- Output by one M20 or M25 cable glands</li> </ul>		151
Y3P5		92 x 124 x 159 mm (1790cm <sup>3</sup> , 902g)	IP69K, IK10	<p><b>Large size enclosure for immersion heater, finned heaters or controls</b></p> <ul style="list-style-type: none"> <li>- Can receive backside holes for 1"1/4, 1"1/2, M45x2, 2", 2"1/2 and M77x2, fittings with double thread and inner nut, or single thread with rotating ring.</li> <li>- Can accommodate <b>stainless steel wall mounting brackets</b></li> <li>- Can also receive back side holes for <b>finned heating elements</b></li> <li>- Output by one, two or three M20 or M25 cable glands</li> </ul>		152
Y3P6		89 x 124 x 155 mm (1600cm <sup>3</sup> , 525g)	IP69K, IK10	<p><b>Large size enclosure for immersion heater, finned heaters with external adjustment knob</b></p> <ul style="list-style-type: none"> <li>- Cover has deep recess for <b>protected external knob</b>, access from front or side of cover</li> <li>- Can receive backside holes for 1"1/4, 1"1/2, M45x2, 2", 2"1/2 and M77x2, fittings with double thread and inner nut, or single thread with rotating ring.</li> <li>- Designed to receive <b>toggle switch and pilot light</b> on cover, protected against shocks</li> <li>- Can accommodate <b>wall mounting brackets</b></li> <li>- Can also receive back side holes for <b>finned heating elements</b></li> <li>- Output by one or two M20 or M25 cable glands</li> </ul>		154

Because of permanent improvement of our products, drawings, descriptions, features used on these data sheets are for guidance only and can be modified without prior advice

## Summary

# Die cast immersion heaters aluminum enclosures, for industrial applications requesting the highest shock resistance

Type	Pictures	Sizes without cable gland	IP, IK	Features	Fits thermostat or limiter	Page
Y3H1		81 x 132 x 182 mm (1870cm <sup>3</sup> , 1070g)	IP69K, IK10	<p><b>Enclosure with aluminum body, black or transparent polycarbonate cover, for immersion heater or solid state relays (SSR) controls</b></p> <ul style="list-style-type: none"> <li>- The rear side has fins to cool the solid state relays</li> <li>- Size compatible with <b>3-pole static relay or 4 single pole solid state relays</b></li> <li>- Includes slides for printed circuits</li> <li>- The 96x132mm face can receive piercing for 1 "1/4, 1" 1/2 and M45x2 fittings, double thread and inner nut, or single twist ring thread</li> <li>- Output from one, two or three M20 or M25 cable glands on 182 x 96mm faces</li> </ul>		156
Y3H2		95 x 132 x 182 mm (2010cm <sup>3</sup> , 1120g)	IP69K, IK10	<p><b>Enclosure with aluminum body, and plastic cover with transparent window, for immersion heater or solid state relays (SSR) controls</b></p> <ul style="list-style-type: none"> <li>- The rear side has fins to cool the solid state relays</li> <li>- Size compatible with <b>3-pole static relay or 4 single pole solid state relays</b></li> <li>- Includes slides for printed circuits</li> <li>- The 96x132mm face can receive piercing for 1 "1/4, 1" 1/2 and M45x2 fittings, double thread and inner nut, or single twist ring thread</li> <li>- Output from one, two or three M20 or M25 cable glands on 182 x 96mm faces</li> </ul>		157
Y3H3		96 x 132 x 182 mm (2050cm <sup>3</sup> , 1450g)	IP69K, IK10	<p><b>All aluminum enclosure, for immersion heater or solid state relays (SSR) controls</b></p> <ul style="list-style-type: none"> <li>- The rear side has fins to cool the solid state relays</li> <li>- Size compatible with <b>3-pole static relay or 4 single pole solid state relays</b></li> <li>- Includes slides for printed circuits</li> <li>- The 96x132mm face can receive piercing for 1 "1/4, 1" 1/2 and M45x2 fittings, double thread and inner nut, or single twist ring thread</li> <li>- Output from one, two or three M20 or M25 cable glands on 182 x 96 mm faces</li> </ul>		158

Because of permanent improvement of our products, drawings, descriptions, features used on these data sheets are for guidance only and can be modified without prior advice

## Summary







# Die cast immersion heaters aluminum enclosures, for industrial applications requesting the highest shock resistance

Because of permanent improvement of our products, drawings, descriptions, features used on these data sheets are for guidance only and can be modified without prior advice

Type	Pictures	Sizes without cable gland	IP, IK	Features	Fits thermostat or limiter	Page
Y3G1		182 x 132 x 130 mm (2435cm <sup>3</sup> , 1210g)	IP69K, IK10	<p><b>Aluminum and plastic composite enclosure, with polycarbonate cover, for immersion heater with 30 mm offset fitting</b></p> <ul style="list-style-type: none"> <li>- Can accommodate all types of fittings up to M77x2 (with threaded ring or rotating ring)</li> <li>- Up to 2" the fittings are mounted on an aluminum plate that can be rotated to <b>orient the enclosure during installation, without having to open it</b></li> <li>- Can receive a power contactor</li> <li>- Can receive an internal connection block up to 12 ways and up to 10mm<sup>2</sup></li> <li>- Output by one or two M25 cable glands</li> </ul>		159
Y3G2		182 x 132 x 144 mm (2575cm <sup>3</sup> , 1255g)	IP69K, IK10	<p><b>Aluminum and plastic composite enclosure, with transparent window cover, for immersion heater with 30 mm offset fitting</b></p> <ul style="list-style-type: none"> <li>- Can accommodate all types of fittings up to M77x2 (with threaded ring or rotating ring)</li> <li>- Up to 2", the fittings are mounted on an aluminum plate that can be rotated to <b>orient the enclosure during installation, without having to open it</b></li> <li>- Can receive a power contactor</li> <li>- Can receive an internal connection block up to 12 ways and up to 10mm<sup>2</sup></li> <li>- Output by one or two M25 cable glands</li> </ul>		161
Y309		182 x 132 x 144 mm (2795cm <sup>3</sup> , 1565g)	IP69K, IK10	<p><b>All aluminum enclosure, for immersion heater with 30 mm offset fitting</b></p> <ul style="list-style-type: none"> <li>- Can accommodate all types of fittings up to M77x2 (with threaded ring or rotating ring)</li> <li>- Up to 2", the fittings are mounted on an aluminum plate that can be rotated to <b>orient the enclosure during installation, without having to open it</b></li> <li>- Can receive a power contactor</li> <li>- Can receive an internal connection block up to 12 ways and up to 10mm<sup>2</sup></li> <li>- Output by one or two M25 cable glands</li> </ul>		163

## Summary

# Die cast immersion heaters aluminum enclosures, for industrial applications requesting the highest shock resistance

Type	Pictures	Sizes without cable gland	IP, IK	Features	Fits thermostat or limiter	Page
Y3J1		182 x 132 x 210 mm (3066cm <sup>3</sup> , 1540g)	IP69K, IK10	<p><b>Composite aluminum and plastic enclosure, with polycarbonate plain cover, for immersion heater with high 120mm offset fitting</b></p> <ul style="list-style-type: none"> <li>- Compatible only with 2 "½ and M77x2 fittings with rotating ring</li> <li>- The fittings are mounted on an aluminum extension that can be rotated to <b>orient the case during installation, without having to open it</b></li> <li>- Can receive an internal connection block up to 12 terminals and up to 10mm<sup>2</sup></li> <li>- Can receive a power contactor</li> <li>- Output by one or two M25 cable glands</li> </ul>		165
Y3J2		182 x 132 x 225 mm (3206cm <sup>3</sup> , 1290g)	IP69K, IK10	<p><b>Composite aluminum and plastic enclosure, with polycarbonate transparent window, for immersion heater with high 120mm offset fitting</b></p> <ul style="list-style-type: none"> <li>- Compatible only with 2 "½ and M77x2 fittings with rotating ring</li> <li>- The fittings are mounted on an aluminum extension that can be rotated to <b>orient the case during installation, without having to open it</b></li> <li>- Can receive an internal connection block up to 12 terminals and up to 10mm<sup>2</sup></li> <li>- Can receive a <b>power contactor</b></li> <li>- Output by one or two M25 cable glands</li> </ul>		167
Y3I0		182 x 132 x 225 mm (3426cm <sup>3</sup> , 1895g)	IP69K, IK10	<p><b>All aluminum enclosure, with polycarbonate plain cover, for immersion heater with high 120mm offset fitting</b></p> <ul style="list-style-type: none"> <li>- Compatible only with 2 "½ and M77x2 fittings with rotating ring</li> <li>- The fittings are mounted on an aluminum extension that can be rotated to <b>orient the case during installation, without having to open it</b></li> <li>- Can receive an internal connection block up to 12 terminals and up to 10mm<sup>2</sup></li> <li>- Can receive a power contactor</li> <li>- Output by one or two M25 cable glands</li> </ul>		169

Because of permanent improvement of our products, drawings, descriptions, features used on these data sheets are for guidance only and can be modified without prior advice

## Summary

### Pockets, fittings, gaskets, connection blocks, relay boards

Pictures	Fits types	Features	Page
	Compatible with almost all enclosures	<b>Stainless steel fitting, with 3 screws rotating ring, deep drawn body and machined thread, for medium corrosive environments.</b> <ul style="list-style-type: none"> <li>- Fully 316L or 304L stainless steel</li> <li>- Available in 1" 1/4, 1" 1/2, M42x2, 2" 1/2 and M77x2</li> <li>- Allows the assembly of heating elements by <b>TIG welding, brazing or resin filling.</b></li> <li>- Built-in ground terminal</li> <li>- Molded gasket, Silicone or FKM (Viton)</li> <li>- Rotary ring stainless steel.</li> <li>- Stainless steel screws.</li> <li>- Available in <u>unassembled version</u> (to allow TIG welding of the lower plate on the heating elements) or <u>assembled version</u> (for brazing).</li> </ul>	173 174 175 176
	Fits only large enclosures	<b>Stainless steel fitting with wide rotating flange</b> <ul style="list-style-type: none"> <li>- Fully 316L or 304L stainless steel.</li> <li>- Available in 1" 1/4, 1" 1/2, M42x2.</li> <li>- Allows the assembly of heating elements by <b>TIG welding, brazing or resin filling.</b></li> <li>- Ground terminal.</li> <li>- Silicone gasketed or FKM (Viton), type O-Ring.</li> <li>- Stainless steel ring.</li> <li>- Stainless steel screws.</li> <li>- Available in <u>unassembled version</u> (to allow TIG welding heating elements on the lower disk) or <u>assembled version</u> (for brazing).</li> </ul>	177 178 179 180
	All enclosure receiving hole for 2" fitting, and specially the Y3C2 enclosure	<b>2" plastic fittings for corrosive liquids like swimming pool, spas and aquariums waters. With or without built-in pockets</b> <ul style="list-style-type: none"> <li>- Designed to receive dia 25mm cartridge heating elements, 316 stainless steel or titanium. Includes a compression gasket in silicone or FKM (Viton) for these heaters.</li> <li>- Exists with or without 2 built-in pockets for electronic temperature controls and safety.</li> </ul>	181 182
	Compatible with almost all enclosures	<b>Brass fittings, double thread</b> <ul style="list-style-type: none"> <li>- Available from 1" to M 77 x 2.</li> <li>- Ground terminal.</li> <li>- Flat silicone gasket.</li> <li>- Available with brass hexagonal counter nut or threaded rotary ring with three M4 screws, nickel plated steel.</li> </ul>	183
	Compatible with almost all enclosures	<b>Single thread fitting, with or without rotation ring, for usual immersion heaters</b> <ul style="list-style-type: none"> <li>- Available from 1" to M 77 x 2.</li> <li>- Allows the assembly of heating elements by silver solder, tin solder or resin filler.</li> </ul>	184 185 186 187 188
	All fittings types	<b>Fittings gaskets for immersion heaters, thermostats, temperature sensors or level sensors</b> <ul style="list-style-type: none"> <li>- Flat seals in NBR, asbestos-free fiber, silicone, Viton, PTFE.</li> <li>- For sealing the fittings through wall.</li> <li>- Dimensions from 1/2" to M77x2.</li> </ul>	191 192 193 194 195 196
	All fittings types	<b>Lock nuts for fittings used in immersion heaters or thermostats, temperature sensors or level sensors</b> <ul style="list-style-type: none"> <li>- Brass, or stainless steel 304 or 316.</li> <li>- For tightening the fittings through wall.</li> <li>- Dimensions from 1/2" to M77x2.</li> </ul>	197
	Most immersion heater enclosures, except miniature models	<b>Mounting accessories for access to internal and external adjustments</b> <ul style="list-style-type: none"> <li>- Counter brackets for installation of thermostats inside enclosures.</li> <li>- Gasket for thermostat shaft with external knob adjustment.</li> <li>- Silicone boot for access to internal adjustment.</li> <li>- M20 threaded cap for access to internal adjustment with tool.</li> <li>- M25x1.5 waterproof device for 50mm external knob</li> </ul>	198 199 201 202 203

Because of permanent improvement of our products, drawings, descriptions, features used on these data sheets are for guidance only and can be modified without prior advice

## Summary

# Pockets, fittings, gaskets, connection blocks, relay boards

Pictures	Fits types	Features	Page
	Variable models according to enclosures.	<b>Din Rails</b> - 304 stainless steel. - For internal mounting of one or two contactors, a GFCI or other accessories. - Fixing on existing bosses in the enclosures.	200
	Types adapted to each model of enclosure	<b>Plastic connection blocks for installation in immersion heater housings, temperature sensors and level sensors.</b> - Numerous models from 3 to 12 ways, from 2.5mm <sup>2</sup> to 10mm <sup>2</sup> , - Surface or raised mounting to escape the heating elements terminals. - Heat resistant polyamide body. - Screw terminals with clamping elastic square washer, captive.	204 205 206 207
	Y3C6 and Y3E6 only	<b>Dia. 55mm immersion heaters thermowells, without thread, for corrosive baths.</b> - Available in 304L, 316L stainless steel, or titanium. - Length on request - Other diameters on request - Multiple lips gasket in FKM (Viton). - Compatible with the barrels of the standard heating elements in steatite dia. 52mm. - Built in ground terminal.	208
	All enclosure using 2"1/2 and M77x2 fittings	<b>Dia. 55mm immersion heaters thermowells, with 2"1/2 and M77x2 thread.</b> - Available in 304L or 316L stainless steel. - Length on request - Other diameters on request - Compatible with the barrels of the standard heating elements in steatite dia. 52mm. - Built in ground terminal.	209
	Y3C2 only	<b>Dia. 25mm immersion heaters thermowells, without thread, for corrosive baths.</b> - Available in 304L, 316L stainless steel, or titanium. - Length on request - Other diameters on request - Multiple lips gasket in FKM (Viton). - Compatible with the barrels of the standard heating elements in steatite dia. 23mm.	210
	Y3C8 and Y3E8 only	<b>10mm diameter pockets for temperature sensors, thermostats or level detectors, without thread, for corrosive baths</b> - Can be made in stainless steel 304L, 316L, stainless steel, Teflon and titanium sheathed. - Length on request. - Compatible with probes up to 8mm in diameter. - Multiple lips gasket in FKM (Viton). - Build-in ground terminal.	211
	For TIG welding on stainless steel enclosures with deep drawn hexagon	<b>Solid or mechanically welded stainless steel fittings for immersion heaters, temperature sensors, level detectors</b> - Can be made on request in 304, 304L, 316, 316L stainless steel. - Dimensions from 1/2" to M77x2.	212 213 214
	Fittings 2", European standard, and 2"1/2 and 3", US standard	<b>Split nuts for spas and swimming pools heaters. Exist for 2 "BSP, 2" 1/2 and 3 "Ansi B1.9 threads (USA).</b>	215
	Available on some enclosures	<b>Relay boards</b> , with one to 6 miniature relays, rating 16A 250V, coil 220/240V. One of their application is to convert single pole devices into 3 poles.	217 218 219
	Usable on some specific enclosures	<b>Various accessories, shutters, external rotation rings. Internal mounting boards for enclosure with controls</b>	216 220 222 223 224 225 226

Because of permanent improvement of our products, drawings, descriptions, features used on these data sheets are for guidance only and can be modified without prior advice





## Technical introduction

We have been building protection boxes for electrical equipment for almost 70 years.

Initially intended to protect rod thermostats, they are now made for many other applications. During their development, we strive to make them in compliance with existing and updated standards, for **professional** applications.

All specifications of our products are thoroughly designed and their performances are **verified**.

Our control laboratory, equipped with more than **600** test machines, is unique, and it is with pleasure that we allow its visit to convince you.

The devices we manufacture aim for the **highest possible quality** and total customer satisfaction.

In our product range:

**No enclosure said « waterproof », but with water ingress,**

**No stainless steel enclosures that rust,**

**No knobs or enclosures in ABS that deform at low temperature,**

**No plastics that do not tolerate UV or transmit inflammation.**





## IP protection classification (Ingress protection)

Because of permanent improvement of our products, drawings, descriptions, features used on these data sheets are for guidance only and can be modified without prior advice

## IP protection (Ingress protection)

### The first 2 characters of IP codification (upon IEC 60259)

The IP rating defined by the IEC 60529 specifies the degree of protection against ingress of solid bodies (first digit) and against the ingress of water (second digit). Third and fourth characters, optional, provide information on the level of protection. The classification is done by increasing efficiency. There are 7 levels against solid (0: no protection, 6 fully protected) and 9 levels against water (0: no protection, 8: protected against immersion under pressure).

For example, "IP21" means protected against solid objects greater than 12.5 mm (e.g. a finger) and resistant to condensation.

**Caution:** Some IP Protection grades can be given for a specified enclosure position.

#### X letter in the codification:

The letter X is used in any place in the code where specifying a digit is meant to be avoided. There may be various reasons for choosing this coding variant, such as marketing considerations. Thus, e.g. an IPX7 rating for a consumer device specifies that the device has water protection up to limited immersion, but gives deliberately no information as to whether the device has any protection against mechanical ingress or dust. Among other common IP ratings using the letter X are IPX4. IP2X is frequently used on electrical items to specify the item must prevent finger access to live terminals i.e. plug sockets are IP2X.

### First digit (Solid particle protection)

The first digit indicates the level of protection that the enclosure provides against access to hazardous parts (e.g., electrical conductors, moving parts) and the ingress of solid foreign objects

**Note:** The first digit of the IP marking is not required by EN 60335-1.

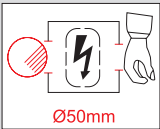
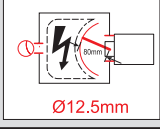
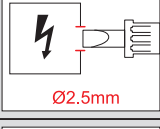
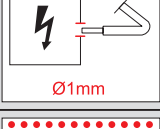
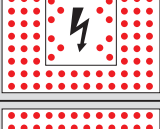
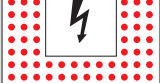
First digit	IP	Pic	Protection type	Features
0	IP0X		No protection	No protection against contact and ingress of objects
1	IP1X		Protected against solid particles >50 mm	Protected against any large surface of the body, such as the back of a hand, but no protection against deliberate contact with a body part.
2	IP2X		Protected against solid particles >12.5 mm	Protected against fingers or similar objects.
3	IP3X		Protected against solid particles >2.5 mm	Protected against tools, thick wires, etc.
4	IP4X		Protected against solid particles >1 mm	Protected against most wires, screws, etc.
5	IP5X		Dust protected	Ingress of dust is not entirely prevented, but it must not enter in sufficient quantity to interfere with the satisfactory operation of the equipment. Completely protected against contact.
6	IP6X		Dust tight	Completely protected against ingress of dust. Completely protected against contact.

# Technical introduction: Ingress protection

## Second digit (Liquid ingress protection)

The second digit indicates the level of protection that the enclosure provides against harmful ingress of water.

IPX1	IPX2	IPX3	IPX4

Second digit	Protection type	Effective protection	Test description
0	Not protected		
1	Dripping water	Dripping water (vertically falling drops) shall have no harmful effect.	- Water equivalent to 1 mm rainfall per minute. - Test duration: 10 minutes
2	Dripping water when tilted up to 15°	Vertically dripping water shall have no harmful effect when the enclosure is tilted at an angle up to 15° from its normal position.	- Water equivalent to 3 mm rainfall per minute. - Test duration: 10 minutes
3	Spraying water	Water falling as a spray at any angle up to 60° from the vertical shall have no harmful effect.	- Water volume: 0.7 liters per minute - Pressure: 80–100 kPa - Test duration: 5 minutes
4	Splashing water	Water splashing against the enclosure from any direction shall have no harmful effect.	Test duration: 5 minutes Water volume: 10 liters per minute Pressure: 80–100 kPa

IPX5	IPX6	IPX7	IPX8

Second digit	Protection type	Effective protection	Test description
5	Water jets	Water projected by a 6.3 mm dia. nozzle against enclosure from any direction shall have no harmful effects.	- Water volume: 12.5 litres per minute - Pressure: 30 kPa - Distance: 3 m - Test duration: 3 minutes
6	Powerful water jets	Water projected in powerful jets (12.5 mm nozzle) against the enclosure from any direction shall have no harmful effects.	- Water volume: 100 litres per minute - Pressure: 100 kPa - Distance: 3 m - Test duration: 3 minutes
7	Immersion up to 1 m	Ingress of water in harmful quantity shall not be possible when the enclosure is immersed in water under defined conditions of pressure and time (up to 1 m of submersion).	- Immersion at depth of at least 1 m measured at bottom of device, and at least 15 cm measured at top of device - Test duration: 30 minutes
8	Immersion beyond 1 m	The equipment is suitable for continuous immersion in water under conditions which shall be specified by the manufacturer. Normally, this will mean that the equipment is hermetically sealed. However, with certain types of equipment, it can mean that water can enter but only in such a manner that it produces no harmful effects.	Test duration: continuous immersion in water. Depth is specified by manufacturer

Because of permanent improvement of our products, drawings, descriptions, features used on these data sheets are for guidance only and can be modified without prior advice

# Technical introduction: Ingress protection

## First additional letter

Additional letters that can be appended to classify only the level of protection against access to hazardous parts by persons	
Letter	Protected against access to hazardous parts with
A	Back of hand
B	Fingers
C	Tools
D	Wires

## Second additional letter

Further letters can be appended to provide additional information related to the protection of the device	
Letter	Meaning
H	High voltage device
M	Device moving during water test
S	Device standing still during water test
W	Weather conditions

## IP69K (DIN 40050-9)

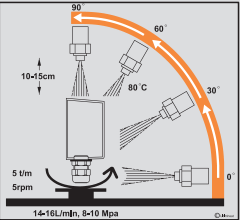
Description	Test description
 <p>Specific ingress protection rating for high-pressure, high-temperature washing applications. Such enclosures must not only be dust tight (IP6X), but also able to withstand high-pressure and steam cleaning</p>	<ul style="list-style-type: none"> <li>- Water volume: 14-16L liters per minute</li> <li>- Water temperature: 80°C</li> <li>- Pressure: 8-10 Mpa (80-100 bar)</li> <li>- Distance: 10 to 15cm from the tested device at angles of 0°, 30°, 60° and 90° for 30s each. The test device sits on a turntable that rotates once every 12s</li> </ul>

## Examples of ingress protection requested by standard and applications

Examples of standards which we recommend you refer to define technical needs for domestic appliances: Room heaters (IEC60335-2-30), Heaters that are built into air conditioners (IEC 60335-2-40); Clothes dryers and towel rails (IEC 60335-2-43); Heaters for saunas (IEC 60335-2-53); Thermal-storage room heaters (IEC 60335-2-61); Heating appliances for breeding and rearing animals (IEC 60335-2-71); Foot warmers and heating mats (IEC 60335-2-81); Flexible sheet heating elements for room heating (IEC 60335-2-96); Heating cables (IEC 60800).





Areas	Minimal IP requirements	Electrical protection
<b>Bath rooms, swimming pools and assimilated</b>	These rooms are divided in 4 area volumes: 0,1,2,3. These volumes and installation rules are described in the French standard NFC15100, International standard Cenelec HD384 and European standard IEC6.364	
0	All electric heaters are prohibited. Other equipments: <u>Bathrooms:</u> IPX7 <u>Pools and similar:</u> IPX8	SELV limited to 12V DC or 30V AC
1	All electric heaters are prohibited. Other equipments: <u>Bathrooms:</u> IPX4, but IPX5 if this volume can be subjected to water jets for cleaning in public baths. <u>Pools and similar:</u> IPX5	SELV limited to 12V DC or 30V AC
2	<u>Bathrooms:</u> IP24 mini heaters are authorized Other equipments: IPX3, but IPX5 if this volume can be subjected to water jets for cleaning in public baths. <u>Indoors Pools:</u> IP24 mini heaters authorized Other equipment: IPX2, but IPX5 if this volume can be subjected to water jets for cleaning. <u>Outdoors Pools:</u> IPX5	<ul style="list-style-type: none"> <li>- Class 2 devices</li> <li>- Controls should not be accessible from the shower or bath.</li> <li>- Heaters must not be powered by a wall mounted socket.</li> <li>- Line must be protected by a 30 mA residual current circuit breaker</li> </ul>
3	<u>Bathrooms:</u> IP21 mini heaters are authorized Other equipments: IPX1 <u>Pools:</u> Heaters authorized IP21 mini Other equipments: IPX1, but IPX5 if this volume can be subjected to water jets for cleaning. <u>Outdoors Pools:</u> IPX5	<ul style="list-style-type: none"> <li>- Class 1 or Class 2 devices</li> <li>- Heaters must not be powered by a wall mounted socket.</li> <li>- Line must be protected by a 30 mA residual current circuit breaker</li> </ul>
<b>Saunas</b>	Electrical equipment must have a minimum degree of protection IP24.	
<b>Underfloor heating</b>	The heating elements intended to be embedded in a concrete or other similar material must be IPX7	
<b>Electrical devices that are permanently outdoor</b>	The degree of protection shall be at least IPX4.	

# Technical introduction: Ingress protection

<b>Residential, Offices, Schools</b>	Generally clean, dry and free from harmful deposits of dust, but some condensate may be present due to atmospheric conditions. Minimum protection is typically IP2X for dry conditions.
<b>Control rooms/ Sub-Stations</b>	Generally dry and free from harmful deposits of dust, but some condensate may be present due to atmospheric conditions. Where access is restricted to skilled or instructed persons, IP2X is the typical minimum requirement for dry conditions.
<b>Commercial, Light industrial premises</b>	It may not be clean, but normally dry and free from harmful deposits of dust. Suitable minimum protection: - Where condensate is not present: IP2X - Where condensate may be present: IP21. - Equipment installed within range of fire sprinkler systems: IP22.
<b>Machine control equipment</b>	Where fluids may be present, e.g. lathes, millers etc., minimum protection typically requested is IP54. Consideration should also be given to the corrosive properties of certain fluids.
<b>Heavy Industrial, Chemical.</b>	These environments are not usually totally clean, with possible presence of corrosive elements and harmful deposits of dust. Protection to IP54 will be typically required, with special consideration given to the corrosion resisting properties of the enclosure. When risk of explosion exists, enclosures and equipment should meet the specifications of these environments.
<b>Food Processing</b>	Will vary depending on the type of food being processed and the possible requirement for washing down. Where fine powders are present, a minimum of IP53 should be used. This should be increased to IP54/65 if the equipment needs to be washed or hosed down. If the equipment is to be washed with hot or cold water under high pressure, the degree of protection IP65 may be insufficient and IP69K may be necessary.
<b>Dump trucks, cement mixers, food industry, car wash</b>	In these high-pressure, high-temperature wash-down applications, enclosures must not only be dust tight (IP6X), but also able to withstand high-pressure and steam cleaning. The recommended protection rating is IP69K. (DIN40050-9)
<b>Weatherproof equipment</b>	If subjected to exposure to any specific weather condition, an agreement between the User and Manufacturer is necessary, with consideration given to specific testing conditions, including the corrosion resisting properties of the enclosure, fittings and cable glands.

## Other classifications

NFC 15100 standard also refers to a "water drop" marking that household appliances and lightings can wear depending on their degree of protection. This marking is different from the IP marking. Double marking, the water drops and the IP code, is not allowed because the tests are different.

Description	Protected against vertical water drops	Protected against rainfall	Protected against splashing water	Protected against water jets	Protected against immersion up to 1 m
IP equivalent	IPX1	IPX3	IPX4	IPX5	IPX7
Standard logo					

## NEMA (USA) rating equivalences with IP

The United States National Electrical Manufacturers Association (NEMA) also publishes protection ratings for enclosures similar to the IP rating system published by the International Electro-technical Commission (IEC). However, it also dictates other product features not addressed by IP codes, such as corrosion resistance, gasket aging, and construction practices. Thus, while it is possible to map IP Codes to NEMA ratings that satisfy or exceed the IP Code criteria, it is not possible to map NEMA ratings to IP codes, as the IP Code does not mandate the additional requirements. The table above indicates the minimum NEMA rating that satisfies a given IP code, but can only be used in that way, not to map IP to NEMA.

North American enclosure rating systems are defined in NEMA 250, UL 50, UL 508, and CSA C22.2 N°. 94.

Equivalent IP Code	Min. NEMA Enclosure rating to satisfy IP Code.
IP20	NEMA-1
IP54	NEMA-3
IP66	NEMA-4, NEMA-4X
IP67	NEMA-6
IP68	NEMA-6P

# Technical introduction: Ingress protection

## IPx5 and IPx6 testing of enclosures in our laboratory



IPx4 test

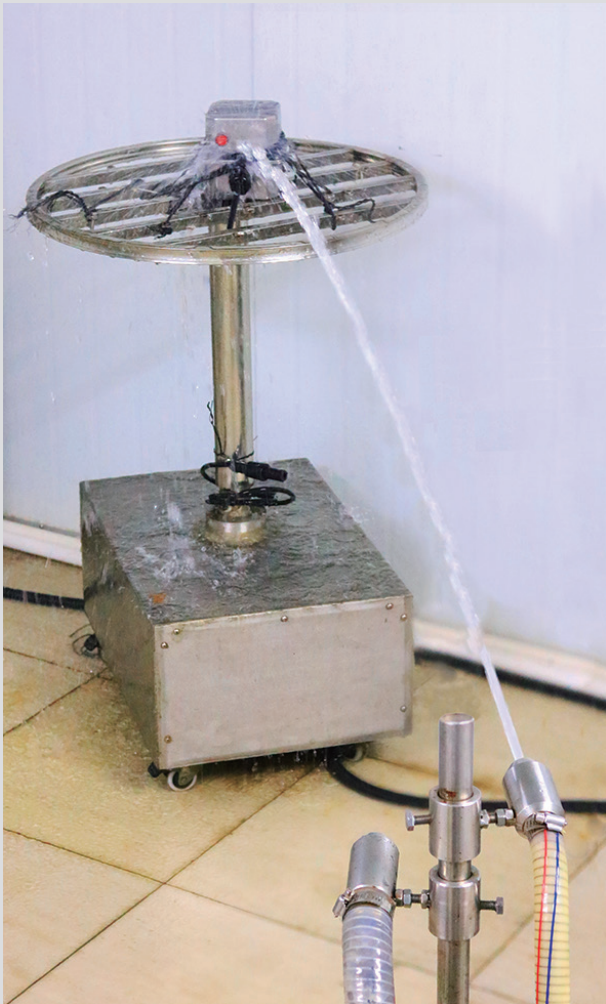

IPx5 test



IPx6 test

Because of permanent improvement of our products, drawings, descriptions, features used on these data sheets are for guidance only and can be modified without prior advice



## Technical introduction: Ingress protection

### IP5x and IP6x (Protection against dust) testing of enclosures in our laboratory



Test chamber



Enclosure during IP6x test

### IPx9K testing of enclosures in our laboratory (water jets at High pressure and high temperature)



Test chamber



Enclosure during IPx9k test

Because of permanent improvement of our products, drawings, descriptions, features used on these data sheets are for guidance only and can be modified without prior advice

# Technical introduction: Ingress protection

---

Because of permanent improvement of our products, drawings, descriptions, features used on these data sheets are for guidance only and can be modified without prior advice



## Electrical protection

Because of permanent improvement of our products, drawings, descriptions, features used on these data sheets are for guidance only and can be modified without prior advice

# Technical introduction: electrical protection



## Electrical protection classes

There are two main types of electrical protection, protection against the risk of **direct contact** (functional isolation) and protection against **indirect contact** hazards.

The functional isolation is not sufficient in case of electrical failure and it is necessary to add protection against the risks of indirect contacts, which can be achieved by the following means:

- The earthing of all metal parts.
- Double or reinforced insulation.
- A low voltage supply via a transformer.

The combination of these protections determines the class of electrical protection device.

Class	Symbole	Description
0		Equipment with only functional insulation but not binding to the metal parts. Banned in Europe.
1		Material with a functional isolation and earthing of metal parts. These devices must be connected to earth.
2		Equipment with dual insulation of live parts (functional insulation and physical insulation). No earthing of metal parts. This double insulation ensures that no accessible part may be subject to dangerous voltages even after a first insulation fault The advantage of this class of appliances is a higher protection to the user regardless of the electrical sockets used (With or without earth terminal). These devices do not need be connected to earth.
3		Equipment class 2 transformer with a SELV (Safety Extra Low Voltage). This solution ensures that no accessible part may be subject to dangerous voltages even after a first and a second insulation fault. The electrical isolation of a device by a transformer located in the gap eliminates the risks for electrical ground return of a user would be accidentally contacted by an electric leakage. On the other hand, the low voltage SELV severely limits the current that can pass through the human body in contact with two elements of the device under different potentials. The advantage of this class of appliances is a higher protection to the user regardless of the electrical sockets used (With or without earth terminal). These devices must not be connected to earth.

## Earthing provisions of metal enclosures and fittings

The design of the grounding connections was made to meet all the points of the EN60335-1 standard, and to ensure a safe grounding, and specially the following requirements:

EN60335-1, § 27.1: Accessible metal parts of class I appliances that may become live in the event of an insulation fault, shall be permanently and reliably connected to an earthing terminal within the appliance.

*To meet this normative obligation, our metal housings and our brass and stainless steel fittings are equipped with at least one grounded terminal. For stamped sheet metal housings, the grounding is performed by a welded terminal having at least two soldering points.*

EN60335-1, § 27.2: The clamping means of earthing terminals shall be adequately secured against accidental loosening. It shall not be possible to loosen the conductors without the aid of a tool.

*To meet this normative obligation, earthing is made by screws needing a screwdriver to screw and unscrew, and have dented washers.*

EN60335-1, § 27.4: All parts of the earthing terminal intended for the connection of external conductors shall be such that there is no risk of corrosion resulting from contact between these parts and the copper of the earthing conductor or any other metal in contact with these parts.

*To meet this normative obligation, the choice of terminal materials and screws is made taking into account the galvanic voltage between materials, to avoid bimetallic corrosion, and favoring, whenever possible, the stainless steel screws and terminals.*

EN60335-1, § 28.1: Earth connections which failures may provide a lack of earthing continuity shall withstand the mechanical stresses occurring in normal use.

Screws used for connections providing earthing continuity shall screw into metal.

*To meet this normative obligation, earth terminals withstand more than one and a half times the nominal tightening torque required by the standards and are threaded in the mass of the metal of the housing or fitting.*

# Technical introduction: electrical protection

---

EN60335-1, § 28.2 Connections providing earthing continuity shall be constructed so that contact pressure is not transmitted through insulating material that is liable to shrink or to distort.

- Thread-cutting (self-tapping) screws shall not be used if they are likely to be operated by the user or installer.
- At least two screws must be used for each connection providing earthing continuity unless the screw forms a thread having a length of at least half the diameter of the screw.

*In order to meet this normative obligation, the earthing terminals of the connectors are designed so that, even when they are used with a plastic housing with an interposed gasket, the tightening of the conductor is done only on metallic parts.*

EN60335-1, § 28.2: Self-tapping screws shall not be used if they can be used by the installer or the user. At least two screws shall be used for each earth connector unless the screw forms a thread having a length of at least half the diameter of the screw.

*To meet this normative obligation, self-tapping screws are never used for grounding, and when the grounding is performed by a screw in a tapping, the length of it is always greater to the value given by the standard.*

28.4 Screws and nuts that make a mechanical connection between different parts of the appliance shall be secured against loosening if they also make connections providing earthing continuity.

- Sealing compound that softens on heating provides satisfactory security only for screw connections not subject to torsion in normal use.

*To meet this normative obligation, the screws of metal covers include a mechanical device avoiding accidental loosening. No sealing compound is used on the screws.*

# Technical introduction: electrical protection

---

Because of permanent improvement of our products, drawings, descriptions, features used on these data sheets are for guidance only and can be modified without prior advice



## Mechanical impact resistance

Because of permanent improvement of our products, drawings, descriptions, features used on these data sheets are for guidance only and can be modified without prior advice

# Technical introduction: Mechanical impact resistance

## Mechanical impact resistance

This mechanical impact is identified by the energy needed to qualify a specified resistance level, which is measured in joules (J). Protection class impact resistance was eventually given previously by the third digit of the IP rating. It was dropped during the 3rd edition of IEC60529 (1978), and replaced by an independent marking specified by the EN62262 standard. There is not an exact correspondence of values between the old and new standards.

Although dropped from the 3rd edition of IEC 60529 onwards, and not present in the EN version, older enclosure specifications will sometimes be seen with an optional third IP digit denoting impact resistance. Newer products are likely to be given an IK rating instead.

### Analysis of the results of the impact tests:

The tests are carried out as follows:

#### For plastics:

1 / On test pieces of identical size (60 mm x 60 mm), thickness 3 mm. A single shock is made in the center of the test piece This provides a comparative table of strength of different materials.

2 / The tests are then carried out on the apparatus, on the cover and on the lateral faces. A first shock is produced in the middle of each face. It is then followed by 4 other shocks evenly distributed over the rest of the surface.

The test is considered successful when the plastic is not split or broken. Of course, the apparatus must retain its ability to function and its degree of tightness.

#### For aluminum or stainless steel cases:

A first shock is produced in the middle of each of the faces of the devices. It is then followed by 4 other shocks evenly distributed over the rest of the tested face.

The test is considered **inconclusive** when the largest deformation measured on the metal at any location of the different impacts is greater than **2mm** Indeed, **although this value is not specified in the standard**, we considered that this permanent deformation would not allow the mounting of accessories.

#### For accessories:

When the cases are equipped with instruments, it is often the accessory which will be the most fragile part and will determine the classification. If the case is equipped with accessories (handle, indicator light, cover, switch, cable gland, etc.), a test is performed in the center of this accessory and in two orthogonal directions. The glands have varying degrees of resistance because they exist in polyamide plastic and also in metal.

The test is considered successful when this accessory is not broken and retains its function.

## IK mechanical impact resistance values upon EN 62262

IK number	Impact energy (Joules)	Equivalent drop mass and height
00	Unprotected	No test
01	0.15	200 g dropped from 7.5 cm
02	0.2	200 g dropped from 10 cm
03	0.35	200 g dropped from 17.5 cm
04	0.5	200 g dropped from 25 cm
05	0.7	200 g dropped from 35 cm
06	1	500 g dropped from 20 cm
07	2	500 g dropped from 40 cm
08	5	1.7 kg dropped from 29.5 cm
09	10	5 kg dropped from 20 cm
10	20	5 kg dropped from 40 cm

## For information: IP third number mechanical impact resistance

**(Obsolete)**





IP third digit	Impact energy (Joules)	Equivalent drop mass and height
0	Unprotected	No test
1	0.225	150 g dropped from 15 cm
2	0.375	250 g dropped from 15 cm

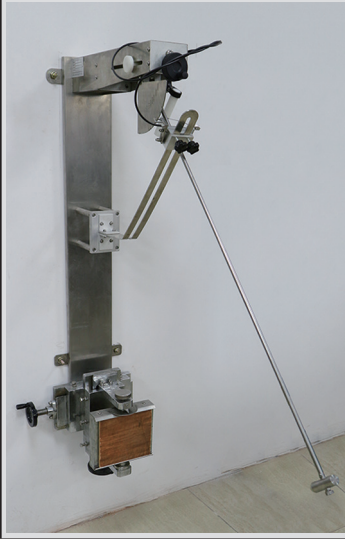

# Technical introduction: Mechanical impact resistance

IP third digit	Impact energy (Joules)	Equivalent drop mass and height
3	0.5	250 g dropped from 20 cm
5	2	500 g dropped from 40 cm
7	6	1.5 kg dropped from 40 cm
9	20	5.0 kg dropped from 40 cm

## IK testing of enclosures in our laboratory

			
Test equipment for IK04 to IK06	Test equipment for IK07 to IK10	IK 10 testing on specimen	IK10 test on enclosure

### Comparative test results of 60 x 60mm plastic specimens, 3mm thickness

Material	PA66, 25%GF	PC	PVDF	PP
IK	10	10	09	10

### Comparative test results of metal specimens of 60 x 60mm, in thicknesses used on enclosures\*

	304 stainless steel			Aluminum		
Thickness	1mm	1.2mm	2mm	1.7mm	2mm	3mm
IK10 impact bump	10.6mm	7.5mm	4.4mm	11.8	9.7	0.45

\* the value of the IK10 impact deformation of flat specimens is indicative but is not representative of the deformation of stamped or molded parts, because the shape is then predominant.

# Technical introduction: Mechanical impact resistance

## IK grade of usual accessories (For information only)

Description	Photos	IK	Description	Photos	IK
Unprotected external knob dia. 40mm		IK09	Internal access soft boot		IK10
External knob dia. 50mm inside a protection recess		IK10	Internal access M25 cap in PA6		IK10
Built in pilot light dia 8mm		IK08	M16 cable gland in PA6		IK10
Unprotected dia. 16mm pilot light		IK08	M20 cable gland in PA6		IK10
Dia 16mm pilot light inside a protection recess		IK10	M25 cable gland in PA6		IK10
Unprotected dia. 22mm pilot light		IK08	M16 cable gland in nickel plated brass		IK10
Unprotected toggle switch		<IK04	M20 cable gland in nickel plated brass		IK10

Because of permanent improvement of our products, drawings, descriptions, features used on these data sheets are for guidance only and can be modified without prior advice

# Technical introduction: Mechanical impact resistance

Description	Photos	IK	Description	Photos	IK
Toggle switch inside recess		IK10	M25 cable gland in nickel plated brass		IK10
Unprotected dome switch		IK10	Miniature Cnomo connector, wall mounted part		<IK04
Dome switch inside recess		IK10	Miniature Cnomo connector, assembled with mobile part		<IK04
Miniature M12 connector, wall mounted part		IK08	M21 connector, wall mounted part		IK10
Miniature M12 connector, assembled with mobile part		<IK04	M21 connector, assembled with mobile part		<IK04
External manual reset cap		IK10			

Because of permanent improvement of our products, drawings, descriptions, features used on these data sheets are for guidance only and can be modified without prior advice

# Technical introduction: Mechanical impact resistance

---

Because of permanent improvement of our products, drawings, descriptions, features used on these data sheets are for guidance only and can be modified without prior advice



## Corrosion resistance of aluminum

Because of permanent improvement of our products, drawings, descriptions, features used on these data sheets are for guidance only and can be modified without prior advice

## Corrosion resistance of aluminum Chemical composition of standard alloy used

Standard	Si	Cu	Mg	Zn	Mn	Fe	Ni	Sn	Ti	Al
ADC12 (JIS H5302:2000)	9.6-12.0	1.5-3.5	<0.3	<1.0	<0.5	0.6-0.9	<0.5	<0.2	-	Remainder

### General corrosion resistance of aluminum enclosures when used outdoor

#### General information on the corrosion of aluminum

Aluminum and alloys generally have good resistance to atmospheric corrosion, in marine, urban and industrial environments. Molded under pressure, aluminum enclosures offer many possibilities of forms and treatments of the surface, require little maintenance and resist well in the time. In addition, with a view to sustainable development, aluminum is one of the metals whose recycling is the most economical. Aluminum remelting is only 5% of the energy required to make the metal from the ore. Aluminum naturally overlies with an oxide layer, which protects it most often against corrosion. In neutral aqueous solutions (4 <pH <9), this oxide film has a thickness of 50 Å and protects the metal (passivation). Aluminum is corroded homogeneously only in a very acidic solution, or in an alkaline solution. The strength and stability of the oxide layer depend on the ambient environment, the alloy composition and the microscopic structure of the metal (depending on the heat treatments applied). The electrochemical behavior of aluminum is influenced by the natural oxide film that governs the corrosion.

The boxes are massive and thick-walled (2 to 4mm); the corrosion is then superficial and affects only the appearance, without modifying the mechanical strength. In neutral environments, the overall corrosion rate of passive aluminum alloys is very small, but it is never totally zero. It thus keeps a value of the order of 5 µm per year, which can lead in the long run to a gradual change in the surface state to an unsightly appearance due to a change in roughness (orange peel).

The most common alteration is in the form of pitting corrosion which develops as cavities of varying depths. This is a very complex phenomenon, the mechanism of which is not fully determined.

In common industrial environments, aluminum housings can therefore be used without surface treatment other than deburring and standard vibration polishing.

### Aluminum Galvanic corrosion, also called Bimetallic Corrosion

Aluminum enclosures may be subject to a particular phenomenon which reduces their service life, can go as far as the perforation of the envelope or the complete locking of the closure screws. It is galvanic or bimetallic corrosion.

Although most standards specify that appropriate safeguards must be in place to prevent galvanic corrosion on aluminum enclosures, none advocates a solution or requires specific material or composition of alloys. However, even if the aluminum is in an unfavorable position in the galvanic scale, it is most often covered with its passive film, which ennobles it considerably and makes it much less sensitive to corrosion.

Galvanic (Bi-Metallic) corrosion is the additional corrosion that occurs when dissimilar metals are in contact in the presence of an electrolyte (e.g. water, sea water). The corrosion of a metal, the anode, results from the positive current flowing from the anode to the less reactive (more noble) metal, the cathode, through the electrolyte.

This process is similar to the conventional corrosion of a single, uncoupled metal but generally proceeds at a higher rate depending on the difference in electrochemical reactivity of the anode and cathode metal.

There is a potential difference between the two metals that depends on both the metal and the solution. Two different metals or two alloys in contact with the same medium usually take two different potentials. If these two metals are electrically connected, their potential difference gives rise to electrochemical reactions and to the circulation of an electric current.

The most negative (the least noble) metal is positively polarized and the most positive metal is negatively polarized. In the vast majority of cases, this configuration corresponds to an increase in the corrosion rate of the most corrodible metal (the most negative), and a decrease in the corrosion rate of the least corrodible metal (the most positive).

### Galvanic corrosion only occurs if the following 4 conditions are present and simultaneous:

- A: An electrolyte bridging the two metals.

When the conductivity of the electrolyte is low, corrosion is localized to the contact areas between the two metals. As the conductivity of the electrolyte increases, the corroded surface increases.

- B: An electrical contact between the two metals.

# Technical introduction: Corrosion resistance of aluminum

If the electrical contact is not established between the two metals by the interposition of an insulator (aluminum oxide, phosphating, paint, oil, etc.), the current does not circulate, there is no corrosion.

- C: A difference in potential between the metals to enable a significant galvanic current.

The higher this value, the greater the electromotive force of the phenomenon. A difference of several hundred millivolts will result in strong galvanic corrosion, whereas a difference of less than 200-300mV will not have significant consequences. These galvanic corrosion potentials are given by a table which gives the electric potential of metals, usually measured by a so-called "Standard Calomel Electrode (S.C.E.)" technique. (See below)

- D: A sustained cathodic reaction on the more noble of the two metals.

## The ratio of the surfaces of the two metals

- The most unfavorable case is that of a large cathodic surface (the most positive material) electrically connected to a small anodic surface (the most negative metal). The corrosion rate of the most negative metal can be multiplied by 100 see per 1000.

For example, stainless steel screws enclosing an aluminum housing will be prone to corrosion due to surface differences.

## Corrosion of the noble metal, and influence of the salts produced by its corrosion

- The corrosion resistance of the noblest metal, regardless of its potential, has a considerable influence on the behavior of the bimetallic corrosion. If the noblest metal corrodes, its corrosion products may, by displacement, accelerate the corrosion of the most corrodable metal. For example, copper, although considered as a noble metal and whose galvanic torque with aluminum is small, produces oxides that can corrode aluminum, which is a critical parameter when designing earth terminal blocks on aluminum housings that can accommodate copper conductors.

## Sacrificial metal coatings

By applying to the cathodic side a sacrificial coating having a potential similar to or near that of the anodic member, the galvanic corrosion is reduced.

Main design rule:

- The sacrificial element should be on the anodic side and smaller.
- Be careful to use fasteners that have an intact coating.

Example:

Zinc plating on steel fasteners will sacrifice the zinc instead of corroding the Aluminum (Potential difference 100 to 200mV).

**Caution:**

Do not use nickel plated steel fasteners, as the potential difference (450mV) between aluminum and nickel is too high and will corrode aluminum.

## Specific issue of galvanic corrosion between Stainless steel and aluminum

The corrosion potentials of the stainless steels are "cathodics" and located in the "noble" area and the corrosion potentials of aluminum are "Anodic" and located in the "non-noble" area, with a large potential difference. This means that there will be no galvanic corrosion on stainless steel when placed in contact with aluminum while aluminum will corrode.

Although aluminum is anodic to stainless steel, large relative surface areas of aluminum to stainless steel can be acceptable, dependent on local conditions.

Stainless steel fasteners in aluminum plates or sheets or massive parts are normally considered safe. Even with no insulation between the metals, there should be little risk of corrosion.

In contrast, in a marine environment, severe localized pitting corrosion to the aluminum treads has been observed where un-insulated stainless steel screws were used.

## Mechanical methods of reducing galvanic corrosion between aluminum and stainless steel

- Isolating the two materials by means of an electrical insulating material, like plastic, wherever practical.
  - Avoid relatively small areas of the less noble metal (Aluminum) and large areas of the more noble metal (Stainless steel).
- NB: Coupling a relatively wide area of aluminum with a small surface area of a cracked stainless steel part can cause a rapid attack of the material inside the crevice and corrode the stainless steel.
- Protect against the electrolyte presence around the bimetallic junction. For example, if possible, paint both metals.
  - Apply corrosion inhibitors under screw heads and threads
  - Apply an insulating organic coating to the contact surfaces before assembly.

# Technical introduction: Corrosion resistance of aluminum

Table of electrochemical voltage between aluminum alloys (Names highlighted in yellow and blue) and other common metals, in a 2% salt water solution.

There is no noticeable occurrence of corrosion when the value of the galvanic torque is less than 300mV.

	Pt (Platinum/ Platine)	Au (Gold/ Or)	Ti (Titanium / Titane)	AISI 316L (passive/passif)	Ag (Silver/ Argent)	Ni (Nickel/ Nickel)	Ni Cu 30 (Monel 400)	NiCr15 Fe8 (Inconel 600)	Cu55 Zn23 Ni22 (Arcap)	Cu (Copper/ Cuivre)	Al10 Sn66 Pb34	Cu Zn34 (Brass/ Laiton)	Cu88 Sn12 (Bronze)	Sn (Tin/ Etain)	Pb (Lead / Plomb)	Al Cu Mg1 (Duralumin)	Mild steel / Acier doux	Al Si 10Mg (Alpax H)	Al 99.5 (Aluminium)	Hard steel/ Acier dur	Al Mg5 (Duralinox)	ADC12 (Aluminium alloy)	Cd (Cadmium/ Cadmium)	Fe (Steel / Fer)	Cr (Chromium/ Chrome)	Al Mg Si0.7 (Almasilium)	Sn75 Zn25	Zn (Zinc/ Zinc)	Al PVD (Physical vapor deposition)	Mg (Magnesium)
Pt (Platinum/ Platine)	0	130	250	250	350	430	430	430	450	570	600	650	770	800	840	940	1000	1065	1090	1095	1100	1100	1100	1105	1200	1200	1350	1400	1400	1900
Au (Gold/ Or)	130	0	110	110	220	300	300	300	320	410	470	520	610	670	710	810	870	935	960	965	970	970	970	975	1070	1070	1230	1270	1270	1820
Ti (Titanium / Titane)	250	110	0	0	110	180	180	180	200	320	350	400	520	550	590	690	750	815	840	845	850	850	855	950	950	1100	1150	1150	1700	
AISI 316L (passive/passif)	250	110	0	0	110	180	180	180	200	320	350	400	520	550	590	690	750	815	840	845	850	850	855	950	950	1100	1150	1150	1700	
Ag (Silver/ Argent)	350	220	100	100	0	80	80	80	100	220	250	300	420	450	490	590	650	715	740	745	750	750	755	850	850	1010	1050	1050	1600	
Ni (Nickel/ Nickel)	430	300	180	180	80	0	0	0	20	110	170	220	340	370	410	510	570	635	660	665	670	670	675	770	770	930	970	970	1520	
Ni Cu 30 (Monel 400)	430	300	180	180	80	0	0	0	20	110	170	220	340	370	410	510	570	635	660	665	670	670	675	770	770	930	970	970	1520	
NiCr15 Fe8 (Inconel 600)	430	300	180	180	80	0	0	0	20	110	170	220	340	370	410	510	570	635	660	665	670	670	675	770	770	930	970	970	1520	
Cu55 Zn23 Ni22 (Arcap)	450	320	200	200	100	20	20	20	0	120	150	200	320	350	380	490	550	615	640	645	650	650	655	750	750	910	950	950	1500	
Cu (Copper/ Cuivre)	570	440	320	320	220	140	140	140	120	0	30	80	200	230	270	370	430	495	520	525	530	530	535	630	630	780	830	830	1380	
Al10 Sn66 Pb34	600	470	350	350	250	170	170	170	150	30	0	50	170	200	210	310	400	465	490	495	500	500	505	600	600	760	800	800	1350	
Cu Zn34 (Brass/ Laiton)	650	520	400	400	300	220	220	220	200	80	50	0	120	150	190	290	350	415	410	445	450	450	455	550	550	710	750	750	1300	
Cu88 Sn12 (Bronze)	770	640	520	520	420	340	340	340	320	200	170	120	0	30	70	170	230	295	320	325	330	330	335	430	430	590	630	630	1180	
Sn (Tin/ Etain)	800	670	550	550	450	370	370	370	350	230	200	150	30	0	40	140	200	265	290	295	300	300	305	400	400	560	600	600	1150	
Pb (Lead / Plomb)	840	710	590	590	490	410	410	410	380	270	240	190	70	40	0	100	160	225	250	255	260	260	265	360	360	520	660	660	1110	
Al Cu Mg1 (Duralumin)	940	810	690	690	590	510	510	510	490	370	340	290	170	140	100	0	60	125	150	155	160	160	165	260	260	420	560	560	1010	
Mild steel / Acier doux	1000	870	750	750	650	570	570	570	550	430	400	350	230	200	150	60	0	65	90	95	100	100	105	200	200	360	400	400	950	
Al Si 10Mg (Alpax H)	1065	935	815	815	715	635	635	635	615	495	465	415	295	265	225	125	65	0	25	30	35	35	40	135	135	295	355	355	885	
Al 99.5 (Aluminium)	1090	960	840	840	740	660	660	660	640	520	490	440	320	290	250	150	90	25	0	5	10	10	10	15	110	110	270	310	310	860
Hard steel/ Acier dur	1095	965	845	845	745	665	665	665	645	525	495	445	325	295	255	155	95	30	5	0	5	5	10	105	105	265	305	305	855	
Al Mg5 (Duralinox)	1100	970	850	850	750	670	670	670	650	530	500	450	330	300	260	160	100	35	10	5	0	0	5	100	100	260	300	300	850	
ADC12 (Aluminium alloy)	1100	970	850	850	750	670	670	670	650	530	500	450	330	300	260	160	100	35	10	5	0	0	5	100	100	260	300	300	850	
Cd (Cadmium/ Cadmium)	1100	970	850	850	750	670	670	670	650	530	500	450	330	300	260	160	100	35	10	5	0	0	5	100	100	260	300	300	850	
Fe (Steel / Fer)	1105	975	855	855	755	675	675	675	655	535	505	455	335	305	265	165	105	40	15	10	5	5	5	0	95	95	255	295	295	845
Cr (Chromium/ Chrome)	1200	1070	950	950	850	770	770	770	750	630	600	550	430	400	380	260	200	135	110	105	100	100	100	95	0	160	200	200	750	
Al Mg Si0.7 (Almasilium)	1200	1070	950	950	850	770	770	770	750	630	600	550	430	400	380	260	200	135	110	105	100	100	100	95	0	160	200	200	750	
Sn75 Zn25	1350	1230	1110	1110	1010	930	930	930	910	790	760	710	590	650	520	420	360	295	270	265	260	260	260	225	160	160	0	40	40	590
Zn (Zinc/ Zinc)	1400	1270	1150	1150	1050	970	970	970	950	830	800	750	630	600	560	460	400	335	310	305	300	300	295	200	200	40	0	0	550	
Zn Al4 (Zamak3/Zamac 3)	1400	1270	1150	1150	1050	970	970	970	950	830	800	750	630	600	560	460	400	335	310	305	300	300	295	200	200	40	0	0	550	
Al PVD (Physical vapor deposition)	1400	1270	1150	1150	1050	970	970	970	950	830	800	750	630	600	560	460	400	335	310	305	300	300	295	200	200	40	0	0	550	
Mg (Magnesium)	1900	1820	1700	1700	1600	1600	1600	1600	1520	1500	1390	1300	1180	1150	1110	1010	950	885	860	850	850	850	850	845	845	845	590	560	560	0

	<b>0-300 mV</b>
	<b>301-500 mV</b>
	<b>501-800 mV</b>
	<b>&gt; 800 mV</b>





## Stainless steel specifications

Because of permanent improvement of our products, drawings, descriptions, features used on these data sheets are for guidance only and can be modified without prior advice

# Technical introduction: Stainless steel specifications

## Main stainless steels used in enclosures

Designation upon American standard AISI	Designation upon European standard EN10027	Designation upon French Afnor standard NF A 35573	Specific gravity (g/cm <sup>3</sup> )	HRB hardness	Tensile Strength, (N/mm <sup>2</sup> )	Elongation (%)
Aisi 304	X5CrNi18-10 1.4301	Z7CN18-09	7.93	<92	>485	>40
Aisi 304L	X2CrNi18-09 1.4307	Z3CN18-10	7.93	<92	>485	>40
Aisi 316L	X2CrNiMo17-12-02 1.4404	Z2CND17-12	7.98	<95	>485	>40

**Note:** in bolts, the A2 marking means a composition similar to Aisi 304L stainless steel, and the A4 marking means a composition similar to Aisi 316L.

## Composition

Type	C	Si	Mn	P	S	Ni	Cr	Mo
Aisi 304	≤ 0.05%	≤ 1.00%	≤ 2%	≤ 0.045%	≤ 0.03%	8-10%	17-19%	-
Aisi 304L	≤ 0.03%	≤ 1.00%	≤ 2%	≤ 0.045%	≤ 0.03%	9-13%	18-20%	-
Aisi 316L	≤ 0.03%	≤ 1.00%	≤ 2%	≤ 0.045%	≤ 0.03%	16-18%	12-15%	2.5-3%

## Main applications

AISI	Overview	Usable in contact with:	Not usable in contact with:
AISI 304	Can be used in contact with water or humid environment. It is the cheapest material mentioned in this list.	<ul style="list-style-type: none"> <li>- Fresh water and natural atmosphere with low chloride content.</li> <li>- Nitric acid up to 52% at all temperatures and 98% cold: 304 or 304L stainless steel resists it particularly well, due to the passivation of its surface. 316L should be used if nitric acid contains impurities.</li> <li>- Organic acids diluted and cold.</li> <li>- Alkaline solutions: the cold solutions have practically no action but it is not the same for concentrated and hot solutions.</li> <li>- Saline solutions not containing chlorides, sulphides and sulphates.</li> <li>- Food products: generally no corrosion problem except with some products that contain sulfur.</li> </ul>	<ul style="list-style-type: none"> <li>- Hydrochloric acid: corrosion increases steadily as the concentration increases.</li> <li>- Chlorinated and hot products.</li> <li>- Bleach at over 60°C and at a high concentration.</li> <li>- Nitric acid mixed with saturated brines.</li> <li>- Saline solutions containing chlorides, sulphides and sulphates.</li> <li>- Food products containing sulfur, such as mustard and white wines.</li> </ul>
AISI 304L	The low carbon content (< 0,03 %) provides better intergranular corrosion resistance after TIG welding than 304. Same chemical resistance than 304.	Similar to AISI 304	Similar to AISI 304
AISI 316L	Excellent resistance to corrosion. The presence of molybdenum enhances chloride resistance by increasing the stability of the superficial passivation layer. The low carbon content (<0.03%) ensures excellent resistance to intergranular corrosion especially after TIG welding. Use in the presence of saline or saline water, and marine environment.	<ul style="list-style-type: none"> <li>- Marine and industrial atmospheres.</li> <li>- Phosphoric acids at all concentrations up to 40°C.</li> <li>- Sulfuric acids less than 10% and more than 80% at 20°C.</li> <li>- Sulphonic mixtures up to 70°C</li> <li>- Sulphurous solutions and vapors, even boiling.</li> <li>- Saline solutions except chlorides.</li> <li>- Alkaline solutions all concentrations below 100°C.</li> <li>- In general: Organic, food and pharmaceutical products.</li> </ul>	<ul style="list-style-type: none"> <li>- Hydrochloric acid: corrosion increases steadily as the concentration increases.</li> <li>- Chlorinated and hot products.</li> <li>- Bleach at over 60°C and at a high concentration.</li> <li>- Nitric acid mixed with saturated brines.</li> </ul>

Because of permanent improvement of our products, drawings, descriptions, features used on these data sheets are for guidance only and can be modified without prior advice

# Technical introduction: Stainless steel specifications

## Resistance to atmospheric corrosion

- The resistance to atmospheric corrosion being improved by a polished surface, the standard finish of the enclosures consists of polishing by vibrations in the last manufacturing step.
- All hardware is in stainless steel to avoid electrochemical corrosion.
- Submitted to a 5% salt spray corrosion test, according to the ASTM 117 standard, the enclosures in Aisi 304 and Aisi 304L do not show any trace of corrosion after 1000 hours, and those in Aisi 316L after 2000 hours.

## Salt spray testing of enclosures in our laboratory

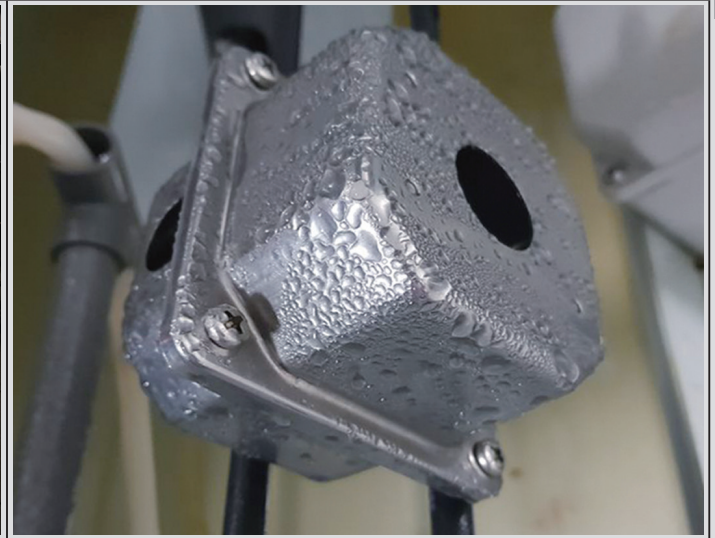

## Galvanic corrosion of stainless steel enclosures

- Galvanized steel in contact with stainless steels is not normally considered to be a serious corrosion risk, except possibly in severe (marine type) environments.

In these situations, precautions such as insulating barriers are usually considered adequate to avoid bimetallic corrosion in most practical situations.

## Stainless steel Rohs compliance

According to the Directive 2011/65/ dated June 8, 2011 (Rohs), stainless steel alloys are allowed to have a maximum of 0.1% by weight of lead, mercury, hexavalent chromium, PBB (Polybrominated biphenyls), PBDE (PolybrominatedDiphenyl Ethers) and 0.01% of Cadmium in weight. (Provisions of Article 4 and paragraph 1 of Annex II)

# Technical introduction: Stainless steel specifications

---

Because of permanent improvement of our products, drawings, descriptions, features used on these data sheets are for guidance only and can be modified without prior advice



## Characteristics of plastics

Because of permanent improvement of our products, drawings, descriptions, features used on these data sheets are for guidance only and can be modified without prior advice

# Technical introduction: characteristics of plastics

## Electrical and mechanical characteristics of plastics used in immersion heater and temperature sensor housings

### Summary of characteristics

Material	Heat deflection temperature under load according to ISO 75 (Values provided by comparative testing made in our laboratory)	Impact resistance on 3 mm thickness board, at 25°C, according to EN50102	Loss of mechanical strength After 1000h UV tests, according to ISO4892-1*	Flammability according to UL94	Mecanical strength according to ISO 572-2	Glow wire flammability index (GWFI), according to IEC 60695-2-12	Main use in enclosures
PC (Transparent)	120°C (1.8 Mpa)	IK10**	Average: loss of 11% of mechanical strength after 1000h	UL94-5V	70 Mpa	850°C	Used for clear covers because it offers very good light transmission (85 to 90%), excellent shock resistance, and withstands high ambient temperatures. Its good UV resistance makes it suitable for outdoor use. <b>Limited resistance to acids, oils and fuels.</b>
25% Fiber glass reinforced PA66 (Black)	226°C (1.8 Mpa)	IK10**	Excellent : loss of only 7% of mechanical strength after 1000h	UL94 VO and UL94-5V depending of thickness	150 Mpa	960°C	The best compromise between impact resistance, temperature resistance, fire resistance and UV resistance. Usable in most industrial applications, including outdoors exposed to the sun and inclement weather. Its high resistance to deformation under load at high temperatures is recommended for applications in immersion heaters. <b>Sensitive to concentrated acids, good resistance to hydrocarbons.</b>
PP (Orange)	64°C (1.8 Mpa)	IK10**	17.53%	UL94V0	26 MPa	725°C	Economical solution for acid resistance. Fragile at low temperature, sensitive to hydrocarbons, solvents, acetones and oils. <b>Must not be used at ambient temperatures above 90 ° C.</b>
PVDF (White)	80°C (1.8 Mpa)	IK09	24.78%	UL94V0	57 MPa	960°C	The ultimate solution for applications in the presence of concentrated acids, but low resistance to deformation under load and temperature. <b>Must not be used at ambient temperatures above 70 ° C</b>

\*: UV resistance is improved by the addition of black pigment (carbon black), and this is the main reason for the black colour of most of boxes for outdoor use.

\*\* : IK10 is the maximum class of impact resistance.

Because of permanent improvement of our products, drawings, descriptions, features used on these data sheets are for guidance only and can be modified without prior advice

# Technical introduction: characteristics of plastics

## Chemical resistance of plastics (indicative list according to data available from different suppliers)

Material	Good resistance to	Non resistant to
<b>PC (Transparent)</b>	<p>Acetamide, Amyl Acetate, Ethyl Acetate, Methyl Acetate, Acetone, Acetylene, Butyric Acid, Carboic Acid (Phenol), Chloroacetic Acid, 30-100% Hydrochloric Acid, 50% Chromic Acid, Cresyl Acid, Mono-Chloroacetic Acid, Hydrogen Fluoride from 20 to 100%, Benzo-Sulfonic Acid, Sulfuric Acid (75-100%), Acrylonitrile, Benzoic Aldehyde, Butyl Amine, Amines, Ammonia 10%, Ammonia Liquid, Ammonia Anhydrous, Acetic Anhydride, Aniline, Dimethyl Aniline, Antifreeze, Aqua regia (80% HCl, 20% HNO<sub>3</sub>), Asphalt, Benzene, Benzol, Bisulfate and Calcium bisulfite, Carbon bisulfide, Butadiene, Butyl acetate, Butylene, Ethyl-Methyl-Ketone, Ketones, Mono-Chlorobenzene, Chloroform, Ethyl Chloride, Ferrous Chloride, Cresols, Copper Cyanide, Cyclohexanone, Diacetyl Alcohol, Dichlorobenzene, Dichloroethane, Diethylamine, Diethyl Ether, Dimethyl Formamide, Furfural, Hexane, Hydrazine, Hydroxide e barium, Lithium Hydroxide, Calcium Hypochlorite, Kerosene, Lacquers, Calcium Hydroxide CaC (OH) 2, Potassium Hydroxide KOH, Sodium Hydroxide NaCOH (50% and 80%), Morpholine, Barium Nitrate, Copper Nitrate, Nitrobenzene, Nitromethane, Perchloroethylene, Butyl phthalate, Pyridine, Barium sulphate, Turpentine, Tetrachlorethylene, Carbon tetrachloride, Toluene (Toluol), Xylene</p>	<p>20% Acetic Acid, Arsenical Acid, Carbonic Acid, Citric Acid, Cupric Acid, Fluosilicic Acid, Formic Acid, Nitric Acid (5-10%), Phosphoric Acid (&gt; 40%), Salicylic Acid, Stearic Acid, Sulfuric Acid (&lt; 10%), Butyl Alcohol, Isopropyl Alcohol, Barium Chloride, Benzo-Nitrile, Beer, Barium Carbonate, Gasoil, Ferric Chloride, Cider, Detergents, Petrol, Ferric Nitrate, Formaldehyde 100%, Formaldehyde 40%, Glycerin Engine, Sodium Hydroxide (20%), Aviation Fuel (JP3, JP4, JP5), Lubricants, Calcium Nitrate, Pentane, Brine (Saturated NaCl), Lead Sulphate, Calcium Sulphate, Copper Sulphate, Ferrous Sulphate, Sulfate ferric</p>
<b>20% Fiber glass reinforced PA66 (Black)</b>	<p>Acetaldehyde, Acetamide, Lead Acetate, Ethyl Acetate, Methyl Acetate, Acetone, Methyl Acetone, Acetylene, Carbonic Acid, Citric Acid, Gallic Acid, Maleic Acid, Malic Acid, Oleic Acid, Salicylic Acid, Stearic Acid, Fatty Acids, Acrylonitrile, Amyl Alcohol, Ethyl Alcohol, Isobutyl Alcohol, Benzoic Aldehyde, Aluns Butyl Amine, Ammonia 10%, Ammonia, Anhydrous, Acetic Anhydride, Carbon Anhydride, Aniline, Dimethylaniline, Asphalt, Barium Chloride, Benzene, Beer, Carbon Bisulfide, Calcium bisulfite, Borax (Sodium borate), Butylacetate, Calgon, Barium carbonate, Calcium carbonate, Gas oil, Ethyl-methyl-ketone, Ketones, Chloroform, Benzyl chloride, Calcium chloride, Ethyl chloride, Ferric chloride, Cider, Barium cyanide, Cyclohexane, Detergents, Diacetone alcohol, Dichloroethane, Diethylamine, Lacquer thinner, Carbonated water, Petrol, Ethanol, Ethanolamine, Ether, Butyl Ether, Diethyl Ether, Ethyl Ether, Ethylene Glycol, Ferric Nitrate, Fuels, Formaldehyde 40%, Dimethyl Formamide, Gelatin, Glycerine, Diethylene Glycol, Heptane, Motor Oil, Mineral and Synthetic Hydraulic Oils, Motor Oils ( 1, 2, 3, 5A, 5B, 6), Diesel Oils (20, 30, 40, 50), Mineral and Synthetic Oils, Linseed Oil, Barium Hydroxide, Calcium Hydroxide, Sodium Hydroxide (20% and 50%) %, Sodium Hydroxide (50%), Iodine, Iso-octane, Cane Juice, Grape Juice, Kerosene, Ketchup, Lacquers, Calcium Hydroxide CaC (OH) 2, Sodium Hydroxide NaCOH, Lubricants, Molasses, Naphtha, Barium nitrate, Calcium nitrate, Carbon monoxide, Pentane, Petroleum, Trisodium phosphate, Butyl phthalate, Brine (saturated NaCl), Arsenic salts, Silicone, Liquid beet sugar, Barium sulphate, Ferric sulphate, Barium sulphide, Tetrachlorethylene, Toluene, Varnish, White Spirits, Xylene</p>	<p>Acetic Acid, Benzoic Acid, Hydrobromic Acid, Carboic Acid (Phenol), Chloroacetic Acid, Hydrochloric Acid, Chloric Acid, Chlorosulfonic Acid, Chromic Acid, Cresylic Acid, Cupric Acid, Fluoboric Acid, Monochloroacetic Acid, Hydrogen Fluoric Acid, Fluosilicic Acid, Formic Acid, Hydrofluorosilic acid, Hydrofluorosilic acid, Nitric acid, Perchloric acid, Benzo-sulphonic acid, Sulfuric acid, Sulfuric acid, Butyl alcohol, Isopropyl alcohol, Propyl alcohol, Amines, Antifreeze, Aqua regia (80% HCl, 20% HNO<sub>3</sub>), Benzol, Bromine, Chlorine, Chlorobenzene (mono), Copper Chloride, Ferrous Chloride, Cresols, Copper Cyanide, Dichlorobenzene, Ethane, Fluorine, Formaldehyde, Calcium Hypochlorite, Sodium Hypochlorite (100%), Sodium Hypochlorite (&lt;20% ), Copper nitrate, Oleum, Phenol, Calcium sulphate, Copper sulphate, Ferrous sulphate, Carbon tetrachloride, Sulfur trioxide</p>

Because of permanent improvement of our products, drawings, descriptions, features used on these data sheets are for guidance only and can be modified without prior advice

# Technical introduction: characteristics of plastics

Material	Good resistance to	Non resistant to
PP (Orange)	Acetaldehyde, Acetamide, Lead Acetate, Ethyl Acetate, Acetone, Acetylene, Acetic Acid 20 to 90%, Arsenic Acid, Boric Acid, 20% Hydrogen Bromide, Carbonic Acid, Citric Acid, Cresyl Acid, Cupric Acid, Fluorometric Acid, Hydrogen Fluoride 20% to 50%, Fluosilicic acid, Formic acid, Gallic acid, Glycolic acid, Hydrofluorosilic acid 20% and 100%, Maleic acid, Malic acid, Nitric acid 5 to 20%, Phosphoric acid > 40%, Salicylic acid, Stearic acid, Sulfuric Acid, Sulfuric Acid <75%, Fatty Acids, Acrylonitrile, Rust Removers, Methyl Alcohol 10%, Benzyl Alcohol, Butyl Alcohol, Ethyl Alcohol, Isobutyl Alcohol, Isopropyl Alcohol, Propyl Alcohol, Aluns, Ammonia 10%, Ammonia Liquid, Ammonia, anhydrous, carbonic anhydride (wet), carbon dioxide (dry), aniline, barium chloride, beer, calcium bisulfite, calcium bisulfide, calgon, barium carbonate, carbon carbonate cium, gas oil, chlorobromomethane, calcium chloride, copper chloride, lithium chloride, ferrous chloride, ferric chloride, cider, copper cyanide, detergents, diacetone alcohol, diethylamine, gasoline, ethanol, diethyl ether, ethylene glycol, nitrate Ferric, Fuel oils, Formaldehyde 40%, Dimethylformamide, Gelatin, Glycerin, Diethylene glycol, Motor oil, Aniline, Flaxseed oil, Citric oils, Calcium hydroxide, Sodium hydroxide (20% to 80%), Calcium hypochlorite, Sodium hypochlorite (<20%), Iso-octane, Aviation fuel (JP3, JP4, JP5), Ketchup, Detergent: Calcium hydroxide CaC (OH) 2, Potassium hydroxide KOH, Sodium hydroxide NaCOH, Lubricants, Methylamine, Barium nitrate, Calcium nitrate, Copper nitrate, Lead nitrate, Calcium oxide, Carbon monoxide, Trisodium phosphate, Pyridine, Brine (Saturated NaCl), Silicone, Liquid beet sugar, Lead sulphamate, Calcium sulphate, Copper sulphate > 5%, Sul Iron Ferric Sulfate, Varnish	Methyl Acetate, Chlorosulfonic Acid, 10% Chromic Acid, Concentrated Nitric Acid, Benzosulfonic Acid, Benzoic Aldehyde, Maleic Anhydride, Dimethylaniline, Antifreeze, Benzene, Carbon Bisulfide, Carbon Bisulfide, Bromine, Anhydrous Liquid Chlorine, Amyl Chloride, Ethyl Chloride, Cresols, Barium Cyanide, Cyclohexanone, Dichloroethane, Lacquer Thinner, Chlorine Water, Ethane, Ethanolamines, Ether, Butyl Ether, Ethyl Ether, Fluorine, Furfural, Mineral and Synthetic Hydraulic Oils, Mineral and Synthetic Hydraulic Oil, Aromatic hydrocarbons, Lacquers, Oleum 25% to 100%, Diphenyl oxide, Pentane, Perchloroethylene, Turpentine, Tetrachlorethylene, Carbon tetrachloride
PVDF (White)	20% Acetic Acid, Acetic Acid, Adipic Acid, Arsenical Acid, Benzoic Acid, Boric Acid, 20% and 100% Hydrogen Bromide, Butyric Acid, Carbolic Acid (Phenol), Carbonic Acid, Chloroacetic Acid, 20% to 100% Hydrochloric Acid, 5% to 50% chromic acid, citric acid, Fluorometric acid, 20% to 100% hydrofluoric acid, Fluosilicic acid, Formic acid, Gallic acid, 20 and 100% hydrofluorosilicate acid, Linoleic acid, Maleic acid, Malic acid, Nitric acid (20%) 90%), Oleic Acid, Perchloric Acid, Salicylic Acid, Stearic Acid, Sulfuric Acid, Sulfuric Acid (10 to 100%)	Acetaldehyde, Ethyl Acetate, Acetone, Methyl Acetone, Chlorosulfonic Acid, Methyl Ethyl Ketone, Cyclohexanone, Diacetone Alcohol, Diethylamine, Dimethyl Formamide, Lacquers, Sodium Hydroxide (NaCOH)

## Heat deflection temperature under load according to ISO 75-2

Determination of the temperature of deflexion under load upon ISO75-1 and 3,, is an important parameter to judge of the ability of a plastic raw material to withstand a temperature rise without losing its mechanical strength. This value is requested by some appliances and commercial standards. As we need to compare the various raw materials used in enclosures, all tests have been made in the same condition, under 1.8 MPa load applied at the center of the 10mm width, on 80 x10 x 4mm specimen (Method Af), The 4mm thickness as been selected as being, in the standard choice, the nearest value to the thickness used on plastic enclosures. The temperature rise is 2°C per minute.

The final temperature is registered when the deflexion has reached 0.34mm

Because of permanent improvement of our products, drawings, descriptions, features used on these data sheets are for guidance only and can be modified without prior advice



# Technical introduction: characteristics of plastics

## Heat deflection temperature under load according to ISO 75, made in our laboratory

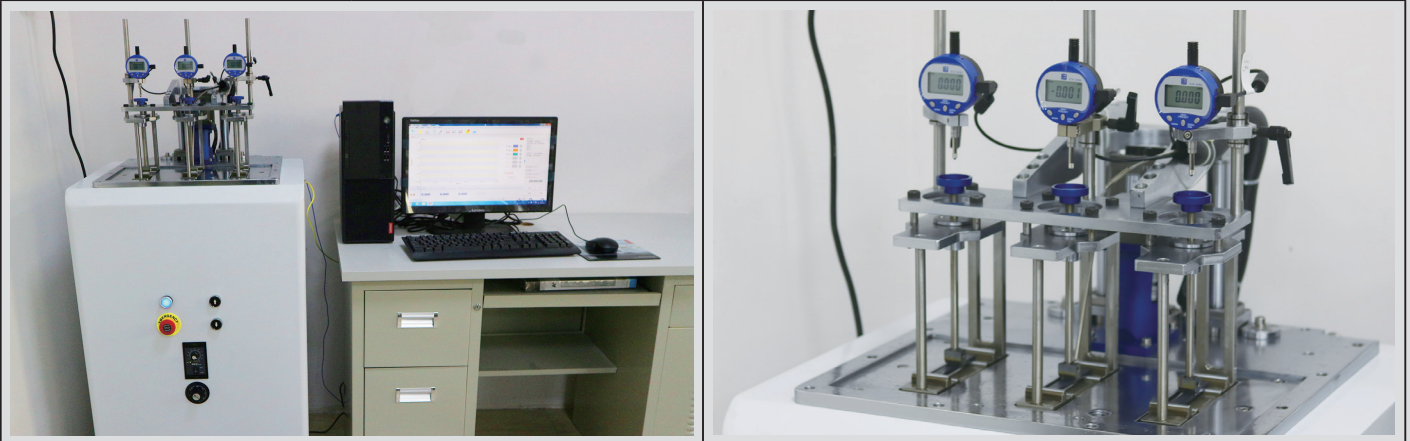

Test Equipment

Test specimens

### Comparative testing values

PP	PC	PA66 25% FG	PVDF
63.6°C	119.6°C	225.6°C	80.4 °C

## UV resistance, upon ISO4892-1

The main problem of plastic cases is their aging in the presence of UV radiation. Most materials, when exposed to solar radiation, become discoloured and lose their mechanical strength. Therefore, the development of our boxes must take into account this parameter.

The validation tests of the boxes are done by subjecting them to a UV flux, wavelength 315 ~ 400nm, on standardized specimens, at a temperature of 55°C, for 1000 hours, equivalent to several years of sun exposure. These tests are carried out according to standard ISO4892-1.

There is no discoloration noticeable on the PA66 cases, and a slight yellowing on the polycarbonate covers.

The loss of Izod mechanical tensile strength is less than 15%, which further complies with UL 746C for enclosures to resist solar exposure.

For information, under the same conditions current boxes in ABS lose 18 to 20% of their resistance.

### 1000 hours UV resistance testing, made in our laboratory, on plastic specimens



UV chamber

# Technical introduction: characteristics of plastics

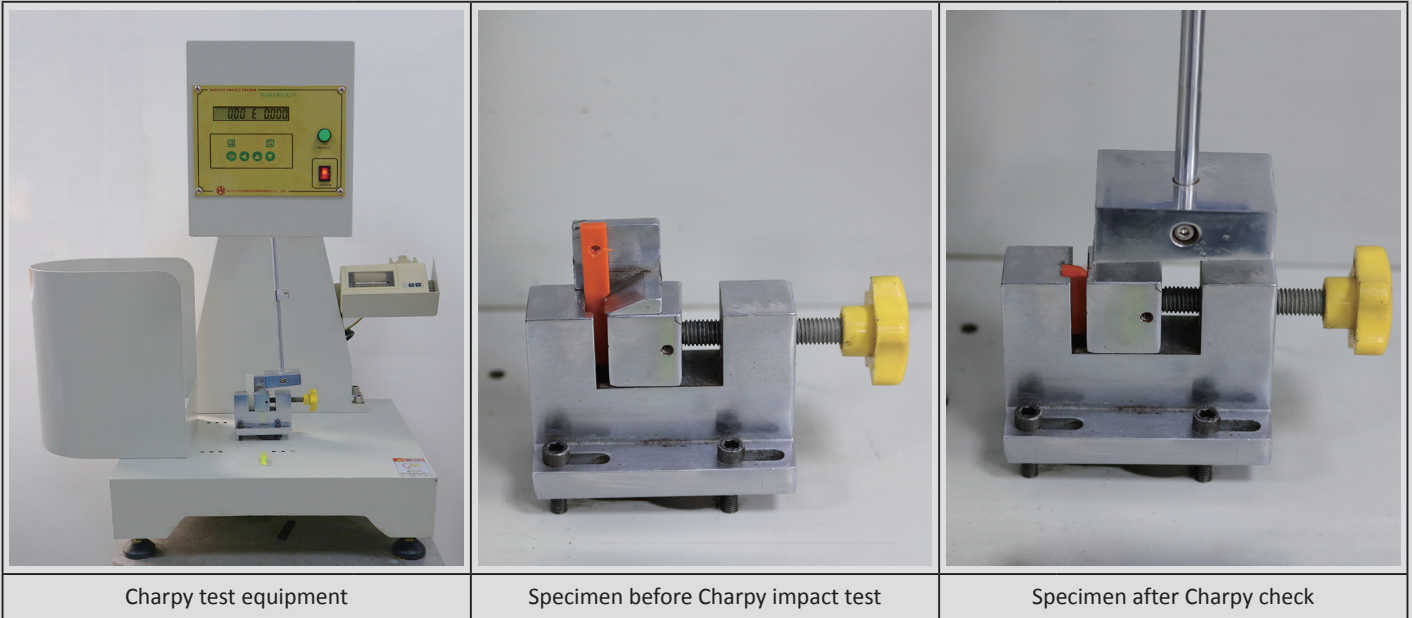

Charpy test equipment

Specimen before Charpy impact test

Specimen after Charpy check

Comparative values of loss of mechanical strength (tests made in our laboratory)

PP	PC	PA66 25% FG	PVDF
17.53%	12%	11.7%	24.78%

## UV colour change measurement (Made in our laboratory)

A comparative examination is carried out between tested and non tested specimens, with measurement of the color change. Color fading is measured with an electronic measurement equipment. Colour change is considered as not visible by a non trained observer when the  $\Delta E$  is lower than 2.5. This is therefore the reason why we selected a  $\Delta E$  of 2.5 as the acceptable limit for this test.

For information, a non trained observer can quite easily see the colour difference with a  $\Delta E$  of 5.

A well trained operator can see an average  $\Delta E$  of 2. The human eyes cannot see a  $\Delta E$  of 1.



Measuring equipment

Measuring  $\Delta E$  on an enclosure cover

Comparative values of color fading after UV (tests made in our laboratory)

PP	PC	PA66 25% FG	PVDF
$\Delta E$ : 4.58	$\Delta E$ : 1.29	$\Delta E$ : 3.19	$\Delta E$ : 2.88

Because of permanent improvement of our products, drawings, descriptions, features used on these data sheets are for guidance only and can be modified without prior advice

## Resistance to corrosion by chlorine, tests performed in our laboratory according to ASTM G48

The test of resistance to corrosion by chlorine is intended to verify the behavior of plastic housings in a chlorinated medium, such as swimming pool and water recreation premise. Test is performed according to ASTM G48: it consists in a 96 hours accelerated corrosion test at 70°C in a concentrated solution of 5.25% sodium hypochlorite (bleach).

- The loss of mechanical strength is observed by a shock test on a Charpy notched specimen before and after the test.
- Weight loss is measured.
- A comparative examination is carried out, with measurement of the color change. As for UV, we selected a  $\Delta E$  of 2.5 as the acceptable limit for this test.

Chlorine resistance test made in our laboratory



	PC	PA66	PP	PVDF
Weight change	+1.06%	+2.34%	+1.47%	0%
Mechanical strength loss	-10%	-12.9%	-10.6%	-11%
Color change	$\Delta E$ : 7.44	$\Delta E$ : 30.67	$\Delta E$ : 13.7	$\Delta E$ : 7.96



## Flammability checking according to UL94, made in our laboratory

The flammability test of the plastics of the enclosures is intended to verify that the accidental ignition of these will not spread and that the ignition will extinguish itself. The class usually required by certification laboratories is UL94-VO, or for some special cases, the highest class, UL94-5V. All the plastics of the boxes are at least UL94-VO in the thicknesses used.

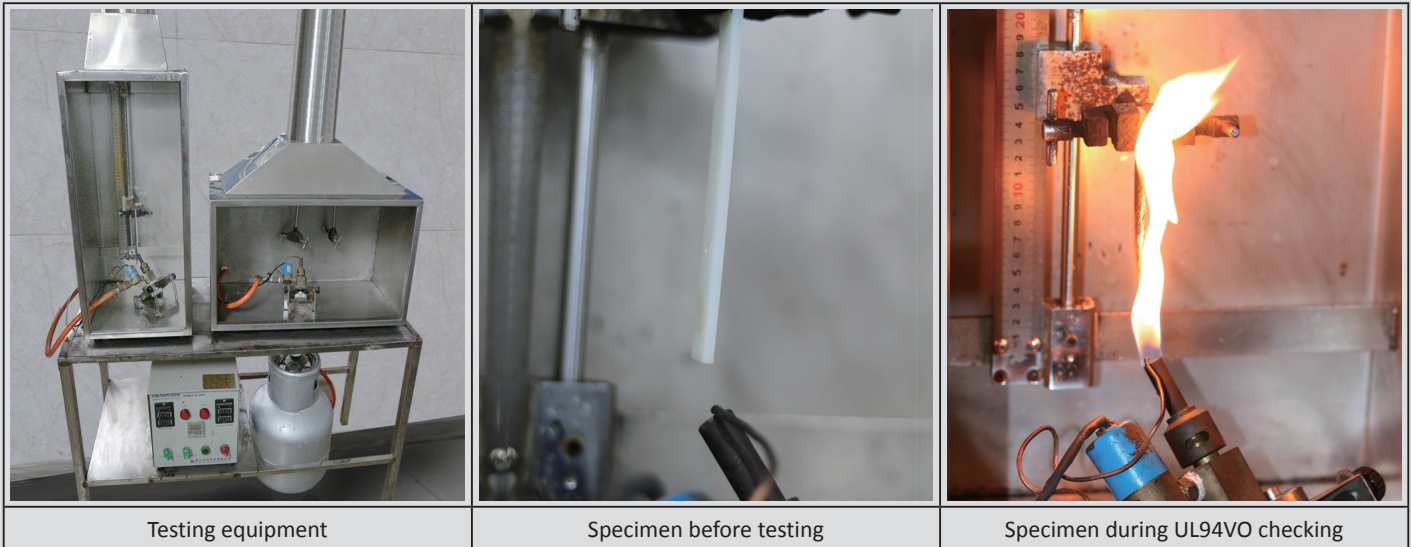

### Gaskets used on enclosures, cable glands and fittings

These gaskets are made of elastomer because it is their flexibility and resilience that guarantees the tightness of the closure. The elastomer used as standard is silicone, because of its flexibility, its resistance to UV and common atmospheric pollutants, and its durability. The joints are molded and applied in specially designed grooves.

However, silicone is not universal, especially when it comes to applications in surface treatment baths or in the presence of acids. It is therefore possible to equip most enclosures with FKM (Viton) fluoroelastomer gaskets

**Indicative and non-limiting list and products not compatible with silicone seals:** Acetone, Hydrobromic Acid, Butyric Acid, Carboic Acid (Phenol), Hydrochloric Acid, Hydrogen Fluoride, Nitric Acid Phosphoric Acid, Sulfuric Acid, Butyl Alcohol, Benzene, Fuel Diesel, Ethyl methyl ketone, Petrol, Tetrachlorethylene, Carbon tetrachloride, Trichlorethylene, White Spirits, Xylene.

**Non-limiting list of products compatible with FKM gaskets:** Acetone, Acetic acid, Hydrobromic acid, Acid, Carboic acid (Phenol), Hydrochloric acid, Chromic acid, Citric acid, Hydrochloric acid Lactic acid, Linoleic acid, Acid Maleic Acid, Oleic Acid, Phosphoric Acid Sulfuric Acid Methyl Alcohol Ethyl, Methyl, Propyl Alcohols; Benzene, Benzol, Chloroform, Calcium Chloride, Detergents, Ether, Ethylene Glycol, Fuel Oil, Hydraulic Oil and Engine Lubricants, Car and Aircraft Fuel, Calcium Hypochlorite, Sodium Hypochlorite, Tetrachlorethylene, Carbon Tetrachloride, Toluene (Toluol), Trichlorethylene, Xylene.

---

## ROHS and Reach

**Rohs:** the materials used in the boxes comply with the European directive 2015/863 Annex II amending Directive 2011/65. Certificates made by an accredited external laboratory available on request.

**Reach:** The materials used in the boxes comply with the REACH European Directives according to the June 2017 directive adding 173 substances SVHC (Substances of Very High Concern) from the list published by ECHA on 12 January 2017, applying to the directive Reach 1907/2006.

Certificates made by an accredited external laboratory available on request.



# Surface finish of metal enclosures

Because of permanent improvement of our products, drawings, descriptions, features used on these data sheets are for guidance only and can be modified without prior advice

## Surface finish of metal enclosures



Surface condition is an essential parameter of resistance against atmospheric corrosion. Both aluminum and stainless steel naturally form a protective oxide layer on the surface. Corrosion occurs only when this protective oxide layer is crossed or destroyed. Microcavities of a rough surface allow atmospheric pollutants to initiate local oxidative conditions. This is particularly critical when these pollutants have a different galvanic potential. For example, iron or iron oxide dust can create favourable conditions for perforating corrosion in stainless steel, as well as zinc in the case of aluminum. It is important that the surface of the metal, if exposed to the weather, be smooth so that these pollutants slide and escape naturally.

### Optional surface treatment





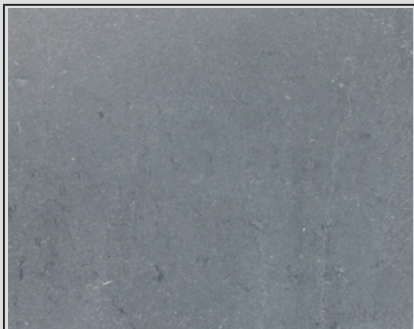



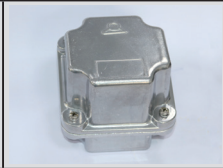
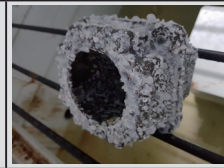
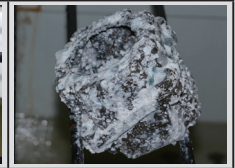

The coating of aluminum boxes with an epoxy-polyester paint will allow them to maintain a better appearance because they cover naturally in the time of an orange-skin-like efflorescent layer, which can be aesthetically detrimental.

This treatment will have the effect of:

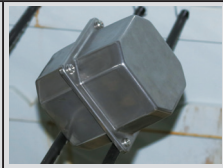
- To improve the general protection of the housing surface against corrosion, when their resistance to natural corrosion is considered insufficient. In addition, this treatment, by interposing an electrically insulating layer between the aluminum and the fasteners or the mounting bracket, will limit the creation of thermoelectric couples initiating corrosion.
- Long-lasting appearance by avoiding pitting corrosion or blackening
- Identify products or product families by their color

	<p>Vibration deburred and polished: this smooth finish improves corrosion resistance. This is the <b>standard</b> surface finish for aluminum and stainless steel enclosures</p>		<p>Epoxy-polyester electrostatic painting, oven polymerized. Colour RAL7035. Enclosures are sand blasted before painted to improve bonding. This is an optional surface finish for aluminum enclosures (other colours on request)</p>
---	--	---	---

## Salt spray testing of metal enclosures in our laboratory

	<b>Material</b>	<b>Starting</b>	<b>After 500h</b>	<b>After 1000h*</b>
	<b>Not painted aluminum</b>			
	<b>Epoxy painted aluminum</b>			
	<b>Stainless steel 304L</b>			
Test equipment	<b>Stainless steel 316L</b>			
<b>Test results</b>				
Aisi 304L and 316L enclosures do not show corrosion, and nor the epoxy painted enclosure. Not painted aluminum enclosure is slightly corroded, and we can see efflorescent white colour bubbles. They can be removed less or more by washing. After rinsing small black corrosion points can be seen with different sizes and depths.				

Because of permanent improvement of our products, drawings, descriptions, features used on these data sheets are for guidance only and can be modified without prior advice

# Technical introduction: Surface finish of metal enclosures

Pictures of the aluminum enclosure, after the 1000h of salt spray test and washing with water

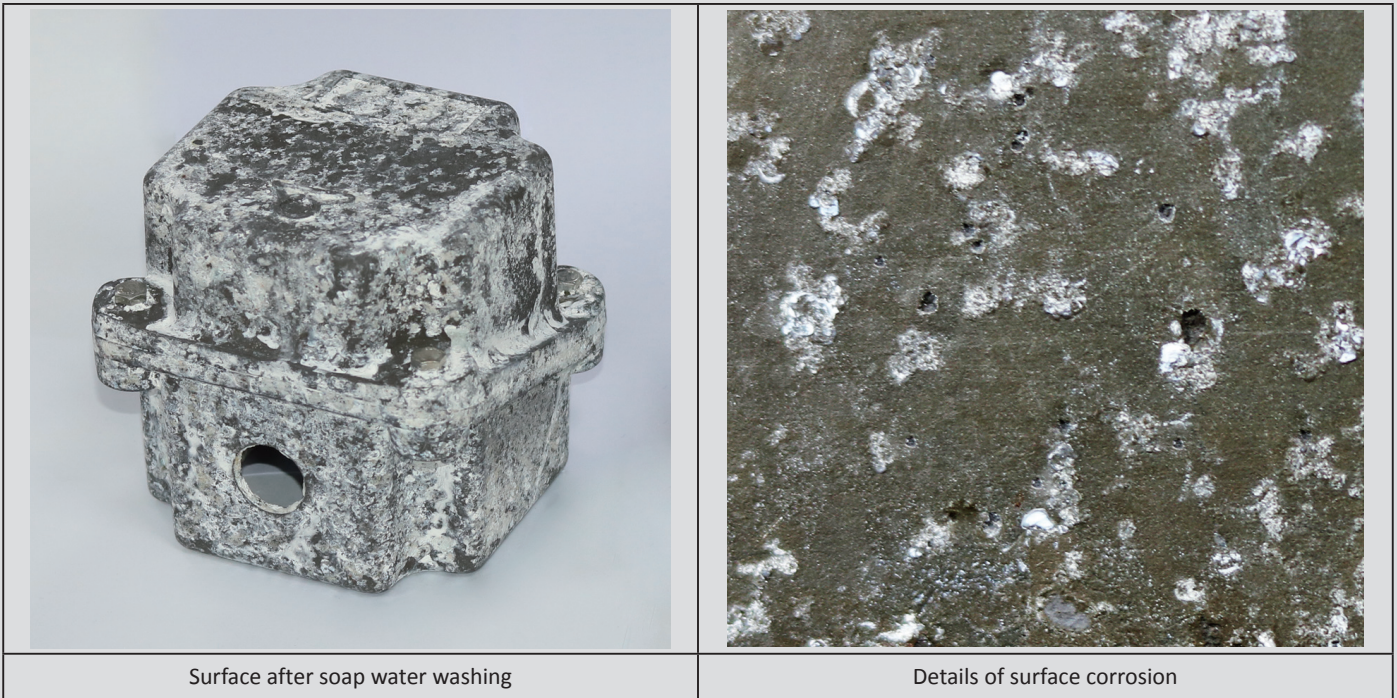

## UV discoloration of epoxy-polyester paint upon ISO4892-1 (comparative tests carried out in our laboratory)

One issue of painted aluminum enclosures cases is their fading in the presence of UV radiation.

The validation tests of the boxes are done by subjecting them to a UV flux, wavelength 315 ~ 400nm, on standardized specimens, at a temperature of 55°C, for 1000 hours, equivalent to several years of sun exposure. These tests are carried out according to standard ISO4892-1.

### 1000 hours UV resistance testing, made in our laboratory, on epoxy painted aluminum enclosures

A comparative examination is carried out between tested and non tested specimens, with measurement of the color change. Color fading is measured with an electronic measurement equipment. As for plastic raw material UV ageing test, colour change is considered as not visible by a non trained observer when the  $\Delta E$  is lower than 5. This is therefore the reason why we selected a  $\Delta E$  of 5 as the acceptable limit for this test.

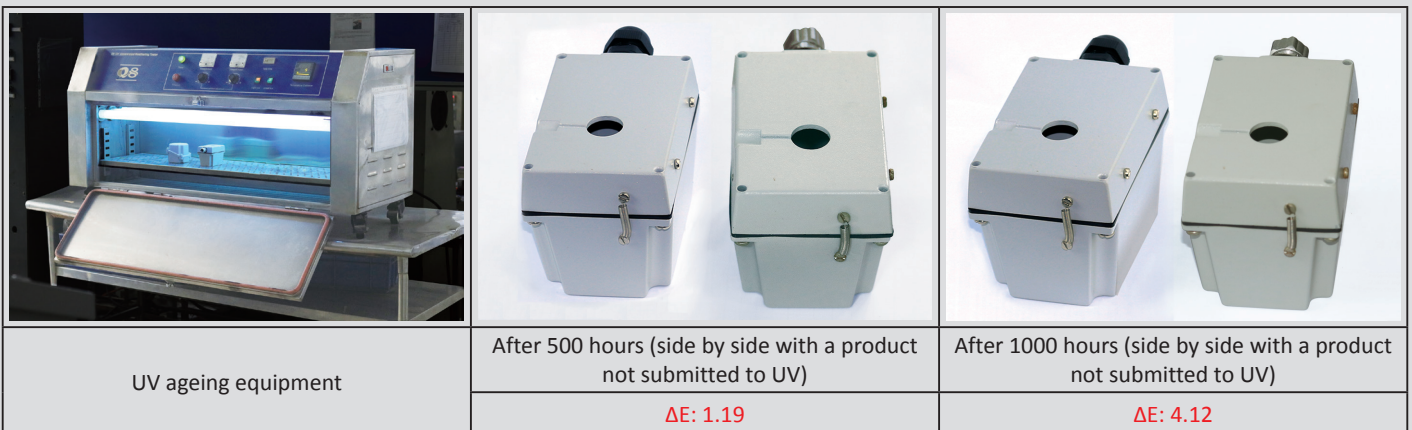

# Technical introduction: Surface finish of metal enclosures

## Resistance to corrosion by chlorine of metal enclosures

### Tests performed in our laboratory according to ASTM G48

The test of resistance to corrosion by chlorine is intended to verify the behaviour of metal housings in a chlorinated medium, such as swimming pool and water recreation premise. Test is performed according to ASTM G48: it consists in a 96 hours accelerated corrosion test at 70°C in a concentrated solution of 5.25% sodium hypochlorite (bleach).

- The loss of mechanical strength is measured by tensile strength at break specimen
- Weight loss is measured.
- A visual comparative examination is carried out, to check corrosion.



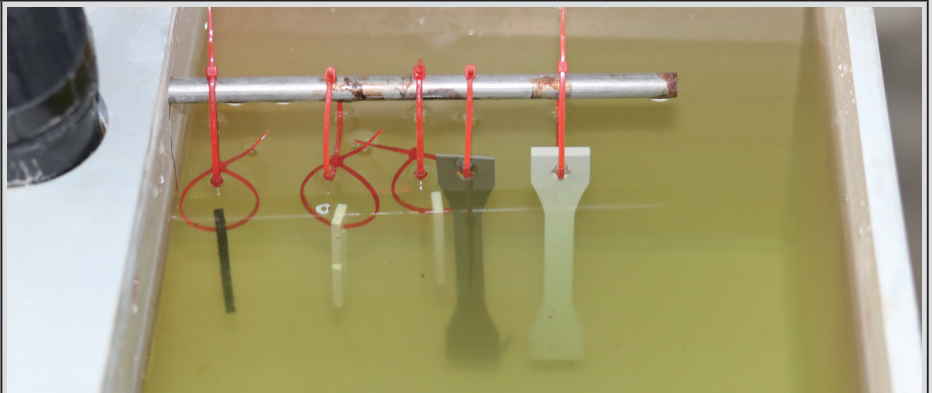

Sodium hypochloride test bath



Specimen location inside the bath

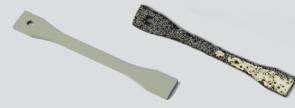

Tensile strength at break measurement equipment

<p><b>Not painted aluminum</b> (before and after 96h test)</p> 		
	<p><b>Epoxy painted aluminum</b></p>	<p>After 24h</p> 
		<p>After 96h</p> 
	<p><b>Aisi 304L stainless steel</b> (before and after 96h test)</p> 	
<p><b>Aisi 316L stainless steel</b> (before and after 96h test)</p> 		

	Specimens tested before and after corrosion test			
	Aluminum	Epoxy painted aluminum	AISI 304L stainless steel	AISI 316L stainless steel
<b>Weight change</b>	Specimen destroyed	Specimen out of use	- 0.1%	- 0.05%
<b>Mechanical strength loss</b> <b>Perte de</b>	100% (Specimen destroyed)	100% (specimen out of use)	56%	45%
<b>Corrosion visual inspection</b>	Specimen quickly fully dissolved	Specimen highly corroded already after 24h	Deep corrosion at some places, initiated by the laser printing.	Slight corrosion marks.

Because of permanent improvement of our products, drawings, descriptions, features used on these data sheets are for guidance only and can be modified without prior advice





## Connection blocks

Because of permanent improvement of our products, drawings, descriptions, features used on these data sheets are for guidance only and can be modified without prior advice

## Connection blocks

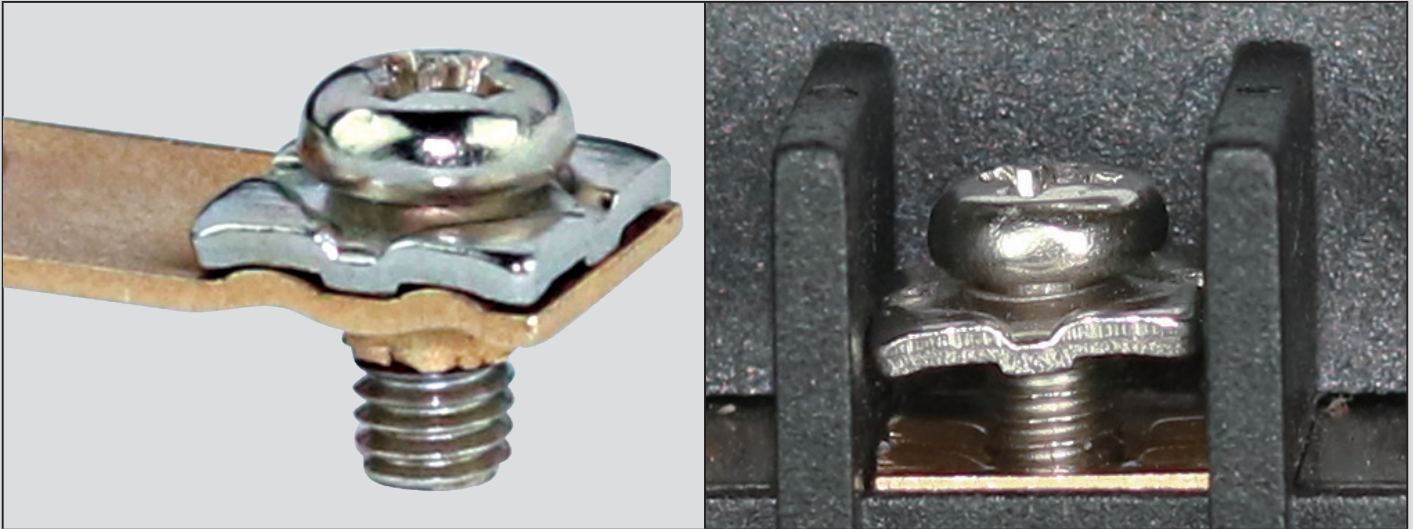

Some enclosures can be supplied with a molded terminal block, standard or optional. These terminal blocks must meet specific specifications because of their application.

However, it is still possible to use ceramic terminal blocks if the ambient temperatures are too high.

### Plastic material

The plastic material of this terminal block, a particular high-end PA66, is different from that of the enclosures, and has been selected to meet the specific constraints of its use.

The most critical constraint that a terminal block can undergo, is a poor tightening of a conductor, the high contact resistance of which causes the terminal to overheat and to melt the plastic material of the support. The class providing the highest resistance to overheating and that of plastics with a GWFI (Glow Wire Ignition Rating) greater than 850°C. **This class is mandatory for applications with unattended use**, according to the specifications of EN60335-1 § 30-2-3-1. The material we use for these terminal blocks has a **GWFI of 960°C**, well above the minimum specifications of this standard. This plastic also offers the best resistance to tracking currents with a CTI > 600 (Class 1, the highest).

Another critical parameter, for these housings intended for immersion heaters or temperature sensors, is the **temperature of deflection under load**. **Measured according to ISO 75**, this plastic material has a particularly high deflection temperature of **282°C** under a 1.8 MPa load.

### Terminals

Depending on the size of the boxes, the terminals include M3, M3.5 or M4 screws. These terminals have the following advantages:

- **Introduction of 2 wires inside each terminal:**

The use of screws with a captive and enveloping square washer, allows to put 2 conductors, even with slightly different size without affecting the quality of tightening.

- **No accidental loosening:**

The elastic effect of the washer also provides good resistance to loosening by vibration.

- **Accept all wires terminations:**

This type of terminal also allows the introduction of single stranded or stranded bare conductors, tinned conductors, fork or eye lugs and conductors with cable shoe.







- **Allows to visualize the good introduction of the wires:**

The end of the terminal, not hidden by a plastic, makes possible to clearly visualize the correct introduction of the wire, frequent source of problems in the terminal boxes with cage, where often it is introduced by mistake under the cage and is not tightened.

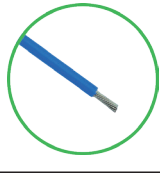
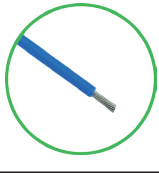
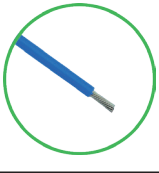
- **Recommended tightening torques: M3: 50 N.cm; M3.5 N.cm: 80; M4: 120 N.cm**

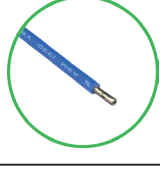
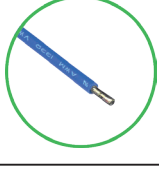
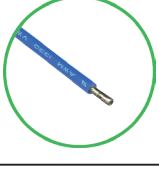
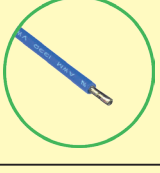
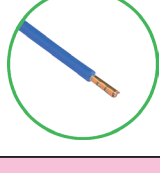
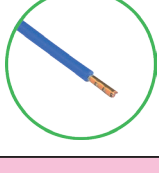
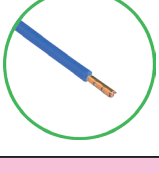
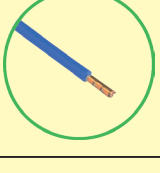
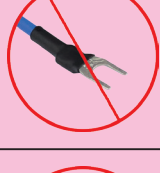
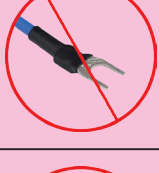
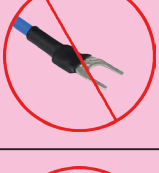
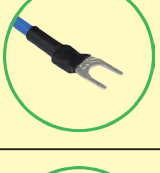
# Technical introduction: Connections blocks

Comparative table of connection types accepted by the different terminal styles

Wires termination styles	Terminal style			
	Direct screw	Screw with plate	Cage terminal	Screw with notched square washer
Bare wire (solid or stranded)				
Bare tinned wire				
Cable shoe				
Spade terminal				
Eyelet terminal				

## Wire pull-out force and vibration loosening resistance

(Tests made in the worst case: a multi-stranded conductor with crimped cable shoe)

Vibration resistance is an important parameter for enclosures terminal blocks, especially if they are installed on trucks, trains or near an engine. In order to verify the effectiveness of the accidental loosening resistance of the terminals, these were subjected to cycles of 10 minutes of variable sinusoidal vibrational sequences covering the range of 1.7 Hz to 5 Hz with variable accelerations from 0.3 to 2.6 G for 48 hours, and the pull-out forces were again measured.

Type	Tightening torque (DaN)	0.5mm <sup>2</sup>	0.75mm <sup>2</sup>	1mm <sup>2</sup>	1.5mm <sup>2</sup>	2mm <sup>2</sup>	2.5mm <sup>2</sup>	4mm <sup>2</sup>
M3 screw (before vibrations)	50 N.cm	65	105	134	151	160	211	
M3 screw (after vibrations)	50 N.cm	62	102	131	147	155	202	
M3.5 screw (before vibrations)	80 N.cm	68	105	142	165	171	220	

Because of permanent improvement of our products, drawings, descriptions, features used on these data sheets are for guidance only and can be modified without prior advice

# Technical introduction: Connections blocks

Type	Tightening torque (DaN)	0.5mm <sup>2</sup>	0.75mm <sup>2</sup>	1mm <sup>2</sup>	1.5mm <sup>2</sup>	2mm <sup>2</sup>	2.5mm <sup>2</sup>	4mm <sup>2</sup>
M3.5 screw (after vibrations)	80 N.cm	65	102	132	162	170	218	
M4 screw (before vibrations)	120 N.cm	86	110	145	157	190	235	260
M4 screw (after vibrations)	120 N.cm	84	107	138	153	185	231	248
Minimum values requested by EN61210		60	85	108	150	200	230	310

## Pull tests, made in our laboratory



Pull test bench



Jaws detail

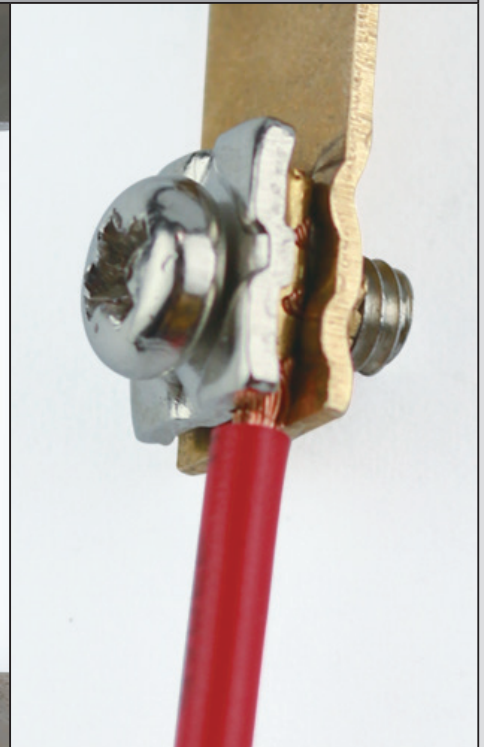

Terminal detail

## Vibration resistance tests, made in our laboratory



Vibration test equipment

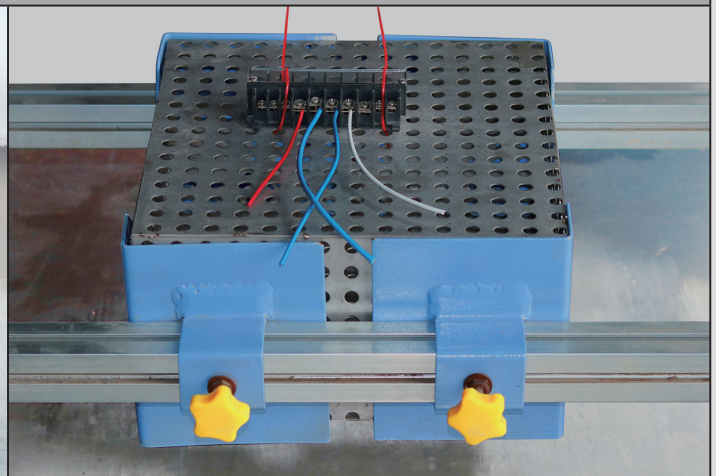

Connection block during test

Because of permanent improvement of our products, drawings, descriptions, features used on these data sheets are for guidance only and can be modified without prior advice



## Immersion heater fittings

Because of permanent improvement of our products, drawings, descriptions, features used on these data sheets are for guidance only and can be modified without prior advice

# Technical introduction: Immersion heater fittings

## Main threads dimensions in Europe

Standard size	1/2"	3/4"	1"	1"1/4	1"1/2	M45x2	2"	2 "1/2	M77x2
Old French designation	15-21	20-27	26-34	33-42	40-49	X	50-60	66-76	X
Outside dia.	21mm	26.4mm	33.3mm	41.9 mm	47.8 mm	45mm	59.6 mm	75.2 mm	77 mm

## Threads main features

In Europe there are two common types of threads used on immersion heaters fittings.

-Threads according ISO 228-1, also said BSPP or cylindrical gas thread (G).

- 2mm pitch metric thread according ISO965-1, little used, which was the subject of an attempt to replace the ISO228-1 in the middle of the 20th century.

The threads are still sometimes described, particularly in France, according to their internal and external diameters.

All these threads are parallel, and therefore requiring a gasket surface to ensure proper sealing. They are mounted on female nozzles, or throw wall with a nut.

Selecting a thread diameter is mainly imposed by the minimum possible bending diameter of sheathed elements brazed or soldered on them. Threads of 1" and below are therefore used on the cartridge heaters.

Heaters are often screwed on nozzles welded on the wall of a tank or heater. The seal is obtained by tightening a gasket, it is impossible to predict in advance what will be the position of the fitting and its connection box when tightening will be effective.

For this reason, internal ring fittings have been developed which allow the case to be rotated after tightening on the tank.

## Comparison of the different systems for fixing immersion heater fittings to enclosures

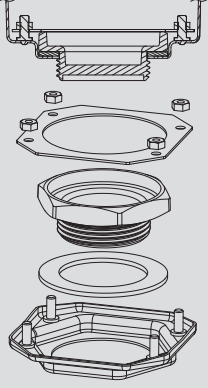
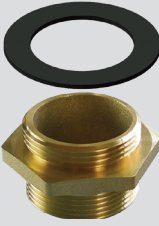
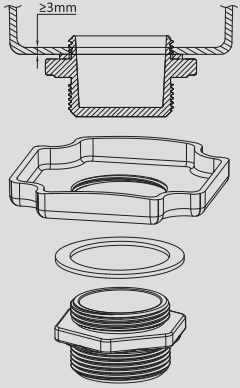
System	Pic	Assembly view	Disadvantages	Advantages
Simple thread fitting, simplified and lightened			<ul style="list-style-type: none"> <li>- This type of fitting, designed for small domestic storage water heaters does not have any device to add an enclosure.</li> <li>- Only specially designed enclosures can be added (Y3L4 and Y3S4)</li> </ul>	<ul style="list-style-type: none"> <li>- The cheapest of all models of fittings. Allows assembly of heating elements by soldering, brazing, or filling with epoxy and PU resins.</li> <li>- Allows to use heating elements with ¼"QC terminals, that can be directly connected on rod thermostats.</li> </ul>
Double thread fitting, screwed directly on taped enclosure			<ul style="list-style-type: none"> <li>- Double thread fitting is expensive</li> <li>- Tapping large diameters is difficult and taps are expensive.</li> <li>- No possibility of adjustment of angular position during assembly on field.</li> <li>- Only possible on thick walls, preferably metal.</li> <li>- Obligation to use a wide flat gasket between the housing and the fitting to prevent it from creeping during tightening.</li> </ul>	<ul style="list-style-type: none"> <li>- Good grounding on the metal housings, without the need for a ground terminal on the fitting.</li> <li>- Economical because no need for locknut or threaded ring.</li> </ul>



Because of permanent improvement of our products, drawings, descriptions, features used on these data sheets are for guidance only and can be modified without prior advice

# Technical introduction: Immersion heater fittings

Because of permanent improvement of our products, drawings, descriptions, features used on these data sheets are for guidance only and can be modified without prior advice

System	Pic	Assembly view	Disadvantages	Advantages
Double thread fitting, assembled through hole, tightened with internal hexagonal nut			<ul style="list-style-type: none"> <li>- The double thread fitting is expensive.</li> <li>- The inner nut is expensive especially in large diameters.</li> <li>- A special tightening wrench is required to tighten the nut.</li> <li>- The large size of the nut limits the placement in the housings.</li> <li>- Obligation to use a wide flat seal between the housing and the fitting to prevent it from creeping during tightening.</li> <li>- The grounding does not meet the standards due to the flexible seal, unless the fitting has its own ground terminal.</li> </ul>	<ul style="list-style-type: none"> <li>- The hole is easy to make.</li> <li>- The orientation of the enclosure is possible during the installation on field.</li> </ul>
Double thread fitting, mounted trough hole, tightened by internal threaded round ring			<ul style="list-style-type: none"> <li>- The double thread fitting is expensive.</li> <li>- The internal threaded ring is expensive especially in large diameters.</li> <li>- The threaded ring must have slots to tighten it with a special tool.</li> <li>- The grounding does not comply with the standards due to the flexible seal, unless the connection has its own earth terminal.</li> <li>- Obligation to use a wide flat seal between the housing and the fitting to prevent it from escaping during tightening.</li> </ul>	<ul style="list-style-type: none"> <li>- The hole is easy to make.</li> <li>- The internal threaded ring is less expensive than a nut.</li> <li>- The size of the ring is smaller than that of a hexagonal nut.</li> <li>- The orientation of the enclosure is possible during the installation on field.</li> </ul>
Double thread fitting, mounted trough hole, pressed by internal threaded ring with 2 or 3 tightening screw M4 or M5			<ul style="list-style-type: none"> <li>- The double thread fitting is expensive.</li> <li>- The internal threaded ring is expensive especially in large diameters.</li> <li>- The grounding does not comply with the standards due to the flexible seal, unless the connection has its own earth terminal.</li> <li>- Obligation to use a wide flat gasket between the housing and the coupling to prevent it from creeping during tightening.</li> </ul>	<ul style="list-style-type: none"> <li>- The hole is easy to make.</li> <li>- The internal threaded ring is less expensive than a nut.</li> <li>- Easy and accessible assembly and tightening of the threaded ring, which does not require special tools.</li> <li>- Orientation of the enclosure is possible during the installation on field.</li> </ul>

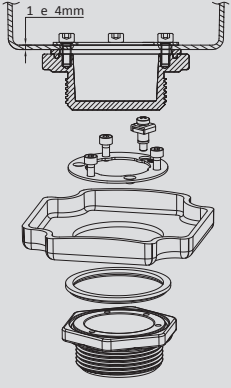

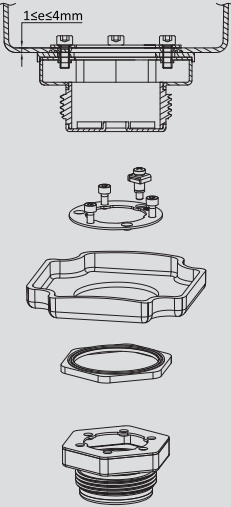
# Technical introduction: Immersion heater fittings

System	Pic	Assembly view	Disadvantages	Advantages
Single thread fitting, with internal rotation ring, tightening with 3 screws			<ul style="list-style-type: none"> <li>- No disadvantage when used with heating elements brazed on the brass fitting.</li> <li>- If the fittings are solid stainless steel, machining is expensive, and the realization of TIG welding on the heating elements is difficult because of differences in thickness.</li> </ul>	<ul style="list-style-type: none"> <li>- Hole easy to make in the enclosure</li> <li>- Single thread fitting approximately 30% cheaper than double thread.</li> <li>- Stamped rotation washer is much cheaper than a threaded internal ring.</li> <li>- Self-centering of the rotation washer provided by 3 bosses</li> <li>- Grounding is made directly on the fitting, independent of the material of the housing and of the seal.</li> <li>- Excellent guiding of the O-Ring type seal, which is maintained in a groove</li> <li>- Easy and accessible assembly and tightening of the ring, which does not require special tools.</li> <li>- Easy orientation of the enclosure during the installation on field.</li> </ul>
Stainless steel single thread fitting, deep drawn body, with internal rotation ring, tightening with 3 screws			<ul style="list-style-type: none"> <li>- Available only in 1" ¼, 1" 1/2, M45x2, 2"1/2 and M77x2</li> <li>- a special gasket must be used to obtain a good seal with the enclosure.</li> </ul>	<ul style="list-style-type: none"> <li>- Much cheaper than a solid machined fitting.</li> <li>- In the assembled version, allows the assembly of brazed heating elements or resin filling</li> <li>- In the unassembled version, allows the assembly of TIG welded heating elements, providing 100% stainless steel immersion heaters.</li> <li>- In this version, easy welding of the heating elements on the cup, made before TIG welding of the cup on the body.</li> <li>- Hole easy to make in enclosure</li> <li>- Stamped rotation washer is much cheaper than a threaded internal ring.</li> <li>- Self-centering of the rotation washer provided by 3 bosses</li> <li>- Grounding is made directly on the fitting, independent of the material of the housing and of the seal.</li> <li>- Excellent guiding of the O-Ring type seal, which is maintained in a groove</li> <li>- Easy and accessible assembly and tightening of the ring, which does not require special tools.</li> <li>- Easy orientation of the enclosure during the installation on field.</li> </ul>

Because of permanent improvement of our products, drawings, descriptions, features used on these data sheets are for guidance only and can be modified without prior advice

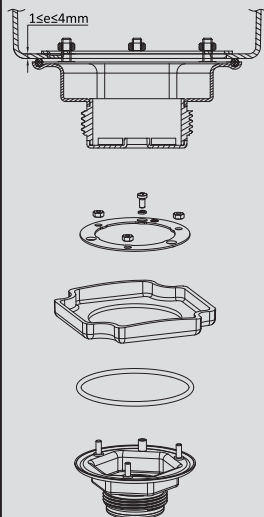

# Technical introduction: Immersion heater fittings

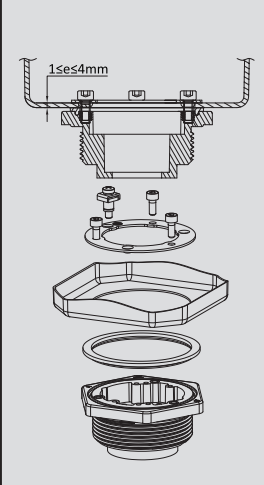
System	Pic	Assembly view	Disadvantages	Advantages
Single thread fitting with large deep drawn flange, tightening by 3 screws on rotation ring			<ul style="list-style-type: none"> <li>- Available only with 1"1/4, 1"1/2 and M 45 x 2 stainless steel fittings.</li> <li>- Cannot be used on small housings due to the big footprint of the flange.</li> </ul>	<ul style="list-style-type: none"> <li>- Hole easy to make.</li> <li>- TIG welding or brazing of heating elements are both possible.</li> <li>- The welded stainless steel fitting on a stamped plate has a removable base allowing to weld TIG directly on heating element tubes.</li> <li>- Stamped rotating washer is much cheaper than a threaded internal ring.</li> <li>- Grounding is made directly on the fitting, independent of the material of the housing and the gasket.</li> <li>- Good guidance of the O-Ring gasket, that is held in a groove.</li> <li>- Easy and accessible assembly and tightening of the washer, which does not require special tools.</li> <li>- Orientation of the enclosure is during the installation on field.</li> </ul>
PPS single-threaded plastic fitting 2" with compressive clamping system for a 25mm diameter tubular heating element. Tightening with 3 screws on a rotating inner washer or 2 screws on a bracket.			<ul style="list-style-type: none"> <li>- Only tooled in 2" thread, for swimming pool heating applications, aquariums and spas with heating by dia. 25mm cartridge.</li> </ul>	<ul style="list-style-type: none"> <li>- Intended for screwing on 2" female PVC fittings commonly used in pools, spas and professional aquariums.</li> <li>- Excellent resistance to saline or chlorinated water, (better than 316L or 316Ti stainless steel).</li> <li>- Allows the mounting of simple and economical stainless steel or titanium heating cartridges.</li> <li>- Can accommodate different sizes of stainless steel enclosures, and PA66 enclosures, with or without thermostat.</li> <li>- One of the versions has two pockets, independent of the heating cartridge, allowing the assembly of temperature sensors.</li> </ul>

## Characteristics of brass used for fittings

GB/T5231-2001 Designation	Nearest equivalences	Specific gravity	HB hardness	Tensile strength Rp0,2 (Mpa)	Extension %
H59Pb1	CuZn39-Pb2 (Afnor-51-104) CuZn37-Pb0.5, (Din 17760) C37000 (ASTM) CW617N (EN12165)	8.4	80-120	350	15-30%

## Composition

Cu	Fe	Pb	Ni	Zn	Impurities total
57~60%	≤ 0.5%	0.08-1.9%	≤1 %	surplus	≤1%

## Brass Rohs compliance

According to the Directive 2011/65/ dated June 8, 2011 (Rohs), copper alloys are allowed to have a maximum of 4% by weight of lead as an alloying element. (Provisions of Article 4 and paragraph 1 of Annex II, limit value set by 6c of Annex III)

# Main drill used in temperature sensors and immersion heater enclosures

Drill diameter (mm)	Main uses
8	Level switches with M8 thread
10	- Thermostat with outside manual reset button - Not waterproof outside adjustment thermostat shaft
10.5	M12 x 1.5 thread for cable glands that must be tapped in the enclosure
12	- M12 x 1.5 cable glands with inside nut - Dia. 12 pilot light
14.5	- M16 x 1.5 thread for cable glands that must be tapped in the enclosure - Dia. 16 pilot light - Dia. 16 main switch
16	-M16 x 1.5 cable glands with inside nut
17.5	½" BSPP stainless steel fitting TIG soldered on bottom of enclosure (hole has a soldering lip)
18.5	-M20 x 1.5 thread for cable glands that must be tapped in the enclosure
19	1/2" BSPP thread that must be tapped in the enclosure
20	M20 x 1.5 cable glands with inside nut
21	½" BSPP thread fitting with inside nut
22	- Dia. 22 pilot light - Dia. 22 main switch
22.5	M24 x 1.5 thread for cable glands that must be tapped in the enclosure
23	¾" BSPP stainless steel fitting TIG soldered on bottom of enclosure (hole has a soldering lip)
23.5	-M25 x 1.5 thread for cable glands or external waterproof thermostat shaft, that must be tapped in the enclosure - Silicone cap for outside access adjustment
24	M24 x 1.5 cable glands with inside nut
24.5	¾" BSPP thread that must be tapped in the enclosure.
25	M25 x 1.5 cable glands with inside nut
26.5	¾" BSPP thread fitting with inside nut
28.5	M30 x 1.5 thread for cable glands that must be tapped in the enclosure
30	M30 x 1.5 cable glands with inside nut
30.5	1" BSPP thread that must be tapped in the enclosure
33.5	1" BSPP thread fitting with inside nut
34.5	1.1/4" BSPP thread that must be tapped in the enclosure
40.6	1.½" BSPP and M45x2 stainless steel fitting TIG soldered on bottom of enclosure (hole has a soldering lip)
42	1.1/4" BSPP thread fitting with inside nut
43	M45x2 thread that must be tapped in the enclosure
45	- M45 thread fitting with inside nut, - 1½" BSPP thread that must be tapped in the enclosure
50	1.1/4" BSPP, 1½" BSPP or M45 thread fitting with inside rotation ring
57	2" BSPP thread that must be tapped in the enclosure, or inside ring
60	2" BSPP thread fitting with inside nut
70	2.½" BSPP and M77x2 stainless steel fitting TIG soldered on bottom of enclosure (hole has a soldering lip)
72.5	2"1/2 BSPP thread that must be tapped in the enclosure
75	M77x2 thread that must be tapped in the enclosure
77	2"1/2 or M77x2 thread fitting with inside nut or rotation ring
80.5	TIG soldering on dia. 80mm tube (hole has a soldering lip)
100.5	TIG soldering on dia. 100mm tube (hole has a soldering lip)

Because of permanent improvement of our products, drawings, descriptions, features used on these data sheets are for guidance only and can be modified without prior advice



## Adjustment or reset access devices

Because of permanent improvement of our products, drawings, descriptions, features used on these data sheets are for guidance only and can be modified without prior advice

# Technical introduction: Adjustment or reset access devices

## Enclosures with devices requiring access from outside

It is often necessary, when the devices include a system of adjustment or a reset, to be able to have access to it, without having to unscrew the lid of the box.

One solution is to use enclosures with an easily opening porthole or window, while protecting the user against electrical contact. This solution is possible for large enclosures.

For small enclosures, special devices have been developed.

### Access under flexible boot

The most common solution is a flexible silicone boot that is easy to open and close.

These boots, whose mobile part is captive, simply install in a hole of 20mm. They can therefore be mounted on all enclosures. These boots, when closed, comply with an IP66 ingress protection degree, but are not adapted to the conditions of the IP69K.

The mounting of internal components such as adjustable or manual reset thermostats, potentiometers etc., can be done either with a back plate screwed inside on the cover (Most aluminum and stainless steel enclosures, and a large part of the plastic ones have bosses for this purpose), or by direct mounting on the bottom of the enclosure.

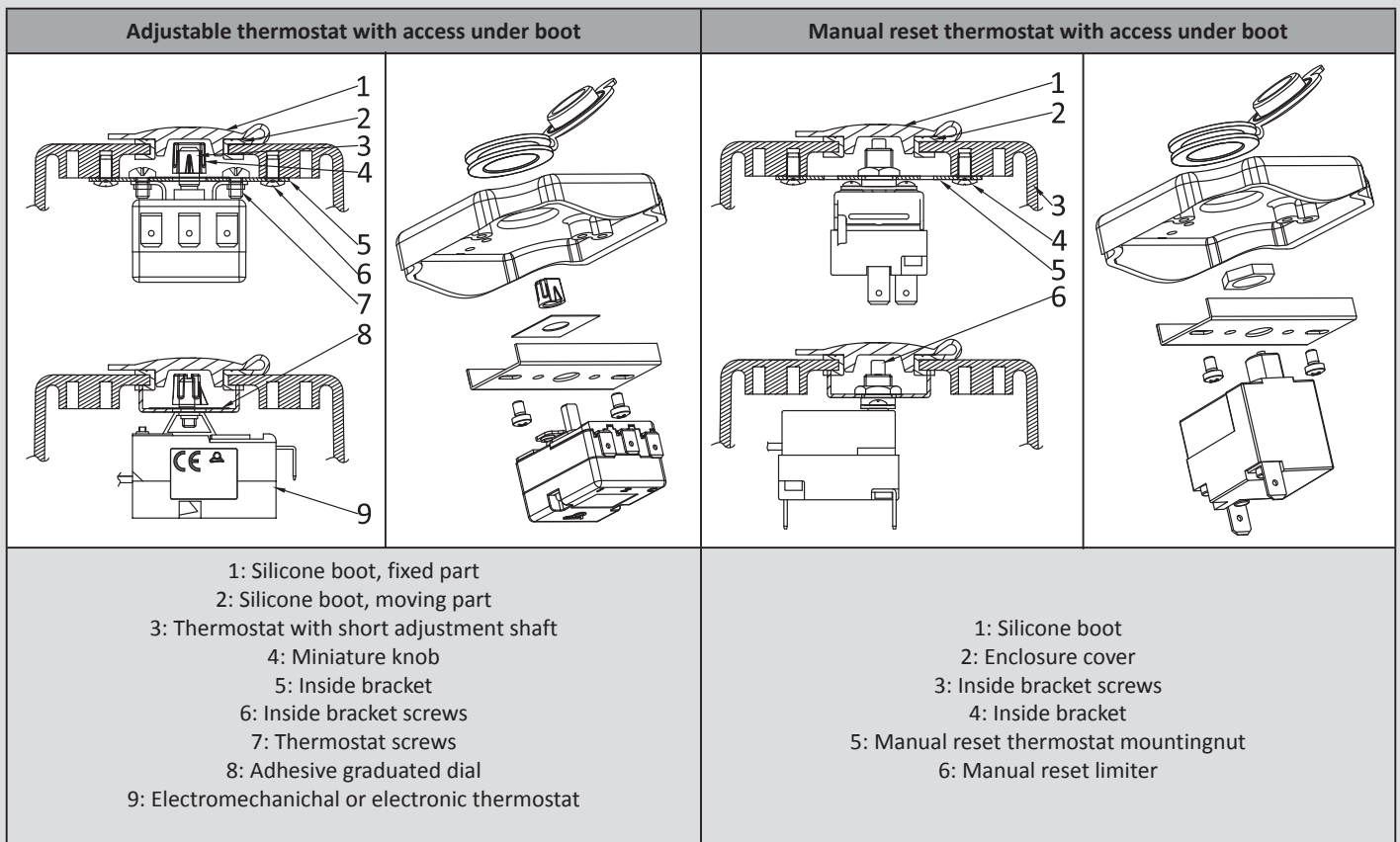
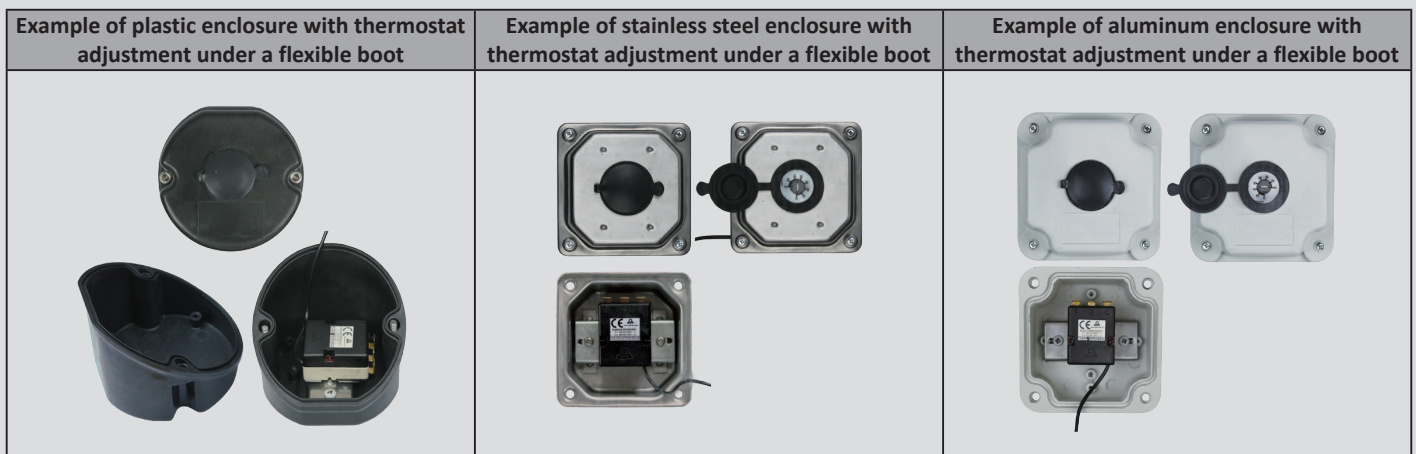

Because of permanent improvement of our products, drawings, descriptions, features used on these data sheets are for guidance only and can be modified without prior advice

# Technical introduction: Adjustment or reset access devices

## Access underscrewed cap

Although less common, it is also possible, on the enclosures whose wall thickness allows it (It must be at least 3mm, which eliminates the stamped metal cases), to make a threaded hole and to install a M20 cable gland cap equipped with a gasket. This solution may be required by the standards, when adjustment or reset can only be done using a tool. With this solution, IP66 and IP69K ingress protection degrees are kept.

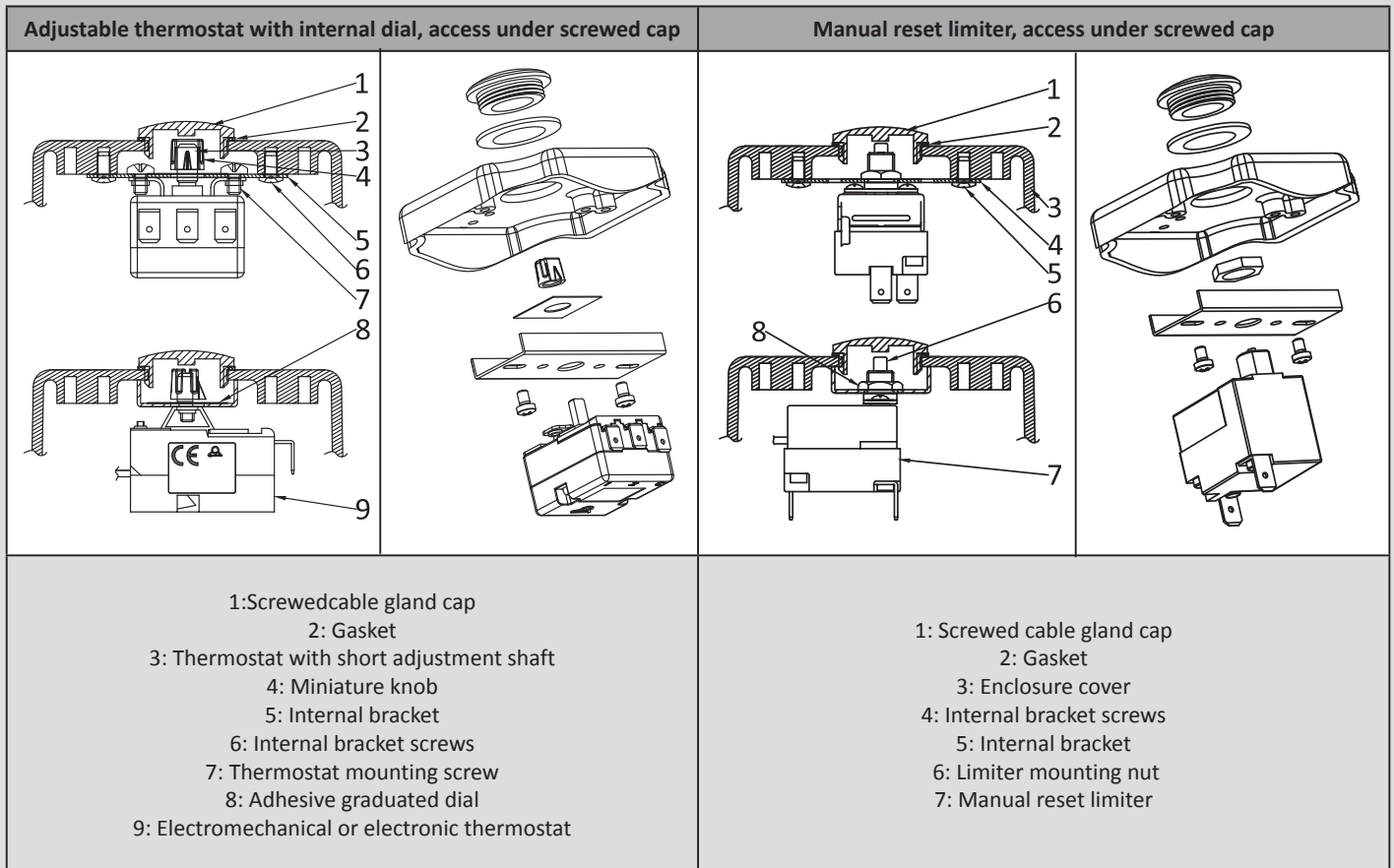
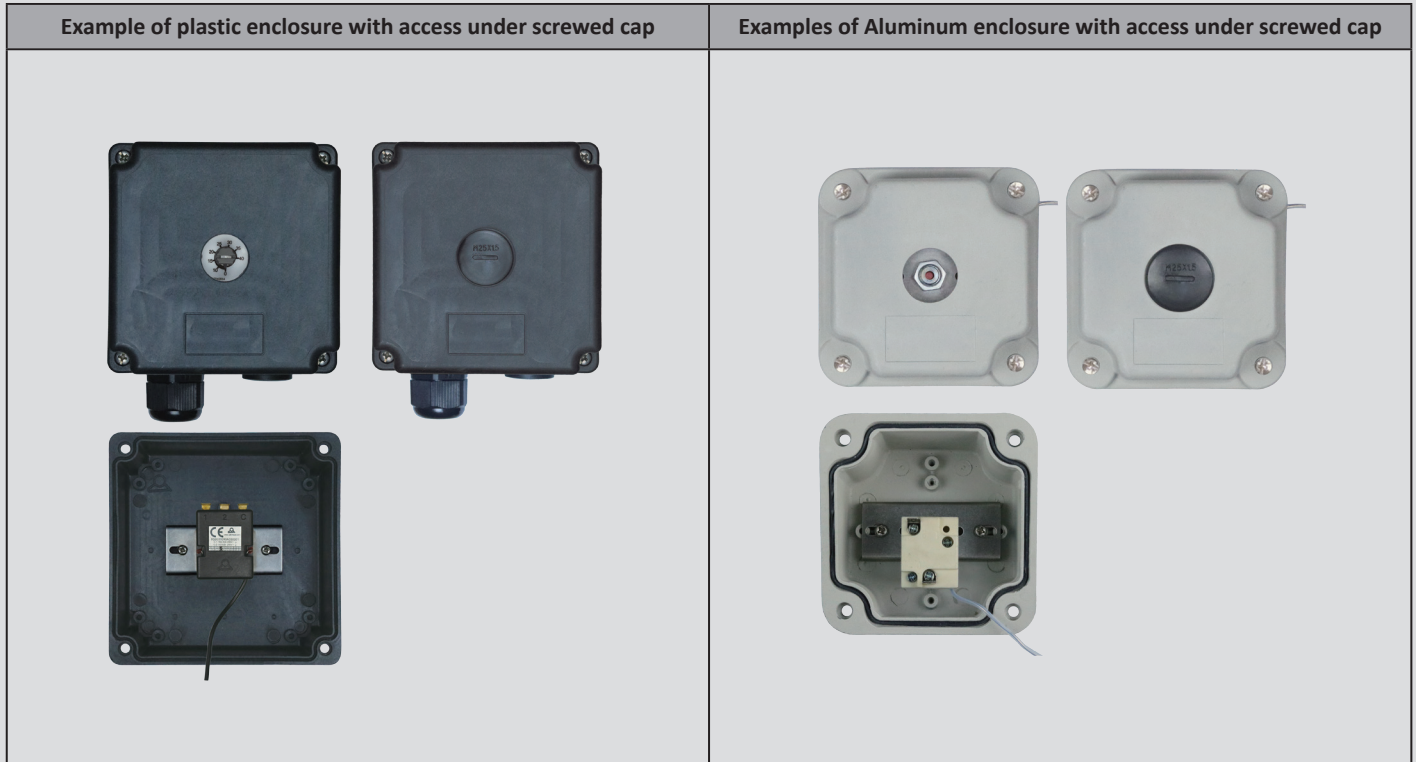

Because of permanent improvement of our products, drawings, descriptions, features used on these data sheets are for guidance only and can be modified without prior advice

# Technical introduction: Adjustment or reset access devices

## Unprotected External access

Adjustment by a shaft or button located outside the housing is the one that offers the lowest guarantee of resistance to water and dust ingress and shock. It is acceptable only when IP54 degree of protection or less are sufficient. In the case of adjustment by a rotary shaft, it is necessary to insert a special gasket on the shaft, sandwiched between the backplate and the cover of the enclosure. Direct mounting without backplate does not allow for proper sealing, as water and dust can penetrate through the adjustment shaft and mounting screws. In the case of access to a manual reset button, it is essential that the protective cap of this manual reset is present, and is equipped with a seal. The main risk is then the loss of this seal and protective cap.

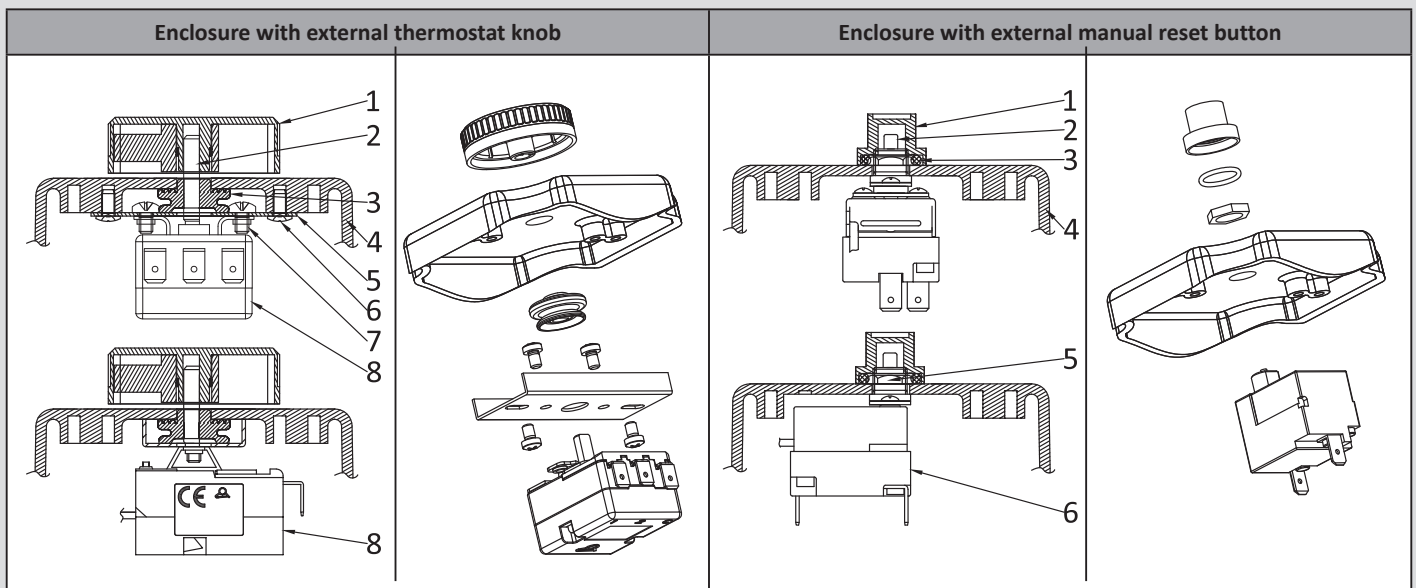
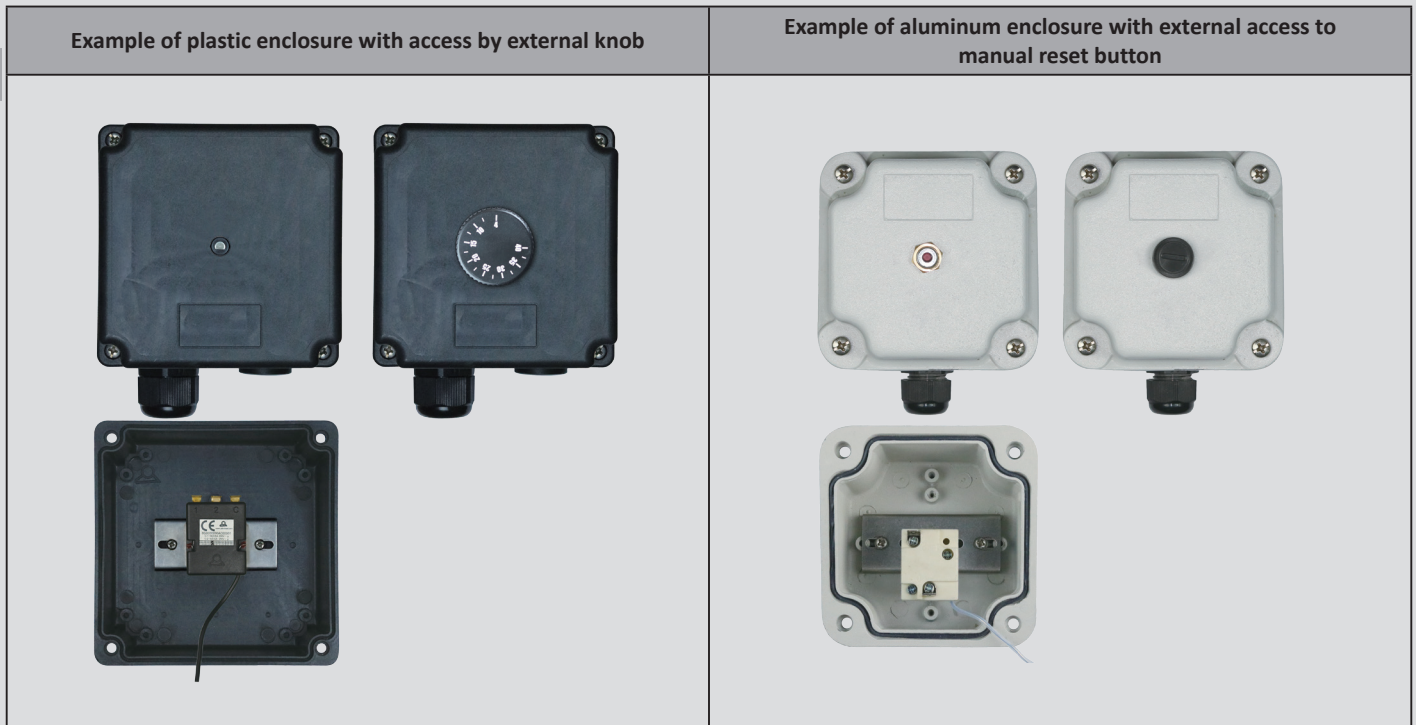

- 1: Graduated knob
- 2: Thermostat with long adjustment shaft
- 3: Silicone gasket with flexible lips
- 4: Enclosure cover
- 5: Internal bracket
- 6: Internal bracket screws
- 7: Thermostat mounting screws
- 8: Electro-mechanical or electronic thermostat

- 1: Screwed manual reset button cap
- 2: Manual reset button
- 3: Manual reset button cap O-Ring
- 4: Enclosure cover
- 5: Limiter mounting nut
- 6: Manual reset limiter

Because of permanent improvement of our products, drawings, descriptions, features used on these data sheets are for guidance only and can be modified without prior advice

# Technical introduction: Adjustment or reset access devices

## External access with IP69K ingress protection

This adjustment by a knob located outside the housing offers a very good guarantee of resistance to water and dust ingress, but limited impact resistance.

This system is suitable for all enclosures in which an M25x1.5 tapping identical to that of screwed cable glands or screw caps can be made. The length of the tapping must be at least 3 mm. The bezel bearing the position marker arrow (Nr 9) can only be used on enclosures with two slots for its pins, such as the Y3C3 model. When this flange is not used, it is necessary to position a marker (paint, blind hole or other) so that the graduation of the controller can refer to it. Only one model of our range of knobs can be used: reference 66MU \*\*\*\*\* , dia. 50mm, with printed. (\*\*\*\*\*= temperature range codification of the knob)

Example of plastic enclosure with access by 50mm external knob, with IP69K ingress protection



Enclosure with external IP69K thermostat knob

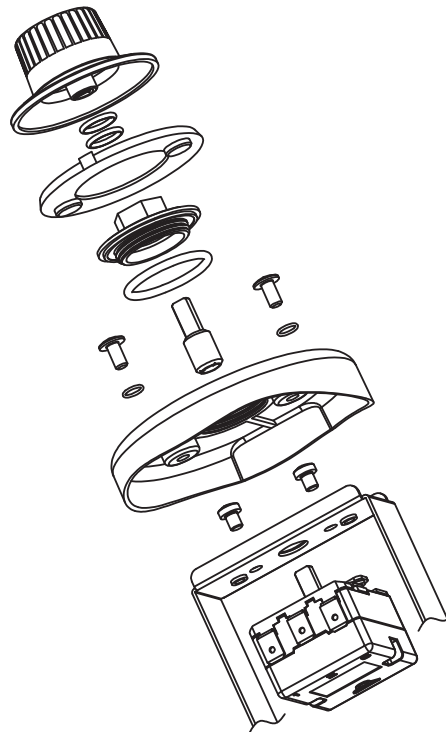
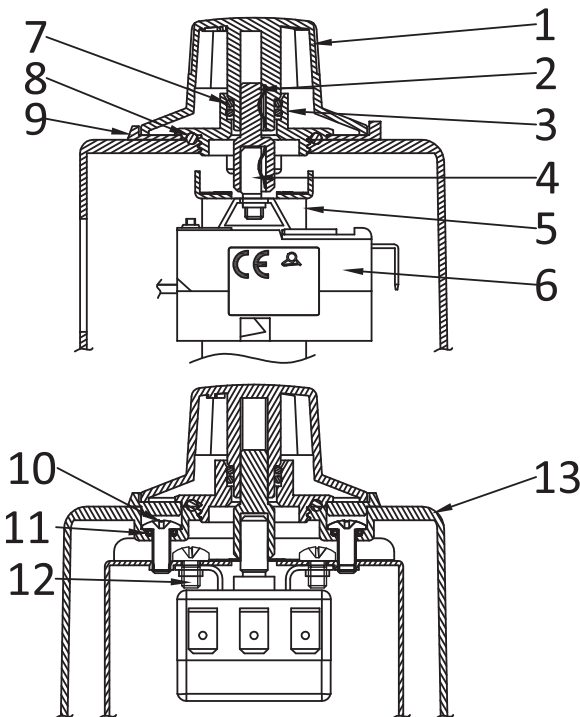

- 1: Graduated knob
- 2: Adjustment shaft extension
- 3: M25x1.5 extension
- 4: Thermostat shaft, with standard 10.5mm length
- 5: Internal bracket
- 6: Electro-mechanical or electronic thermostat
- 7: Knob O-rings
- 8: M25x1.5 extension gasket
- 9: Thermostat bezel
- 10: Internal bracket screws
- 11: Internal bracket screw gaskets
- 12: Thermostat mounting screws
- 13: Enclosure cover with m25x1.5 thread

Because of permanent improvement of our products, drawings, descriptions, features used on these data sheets are for guidance only and can be modified without prior advice

# Technical introduction: Adjustment or reset access devices

## External access, IP69K ingress protection class, withstand high-temperature and high-pressure cleaning, and shocks resistant

This type of external control by means of a waterproof and shock-resistant knob has been developed for all industrial, commercial and **food industry applications**, as well as on transport vehicles, for which **high-pressure hot water jet cleaning** is essential. It allows the setting of a mechanical or electronic thermostat while maintaining its sealing characteristics. The embedding of the control knob provides excellent impact resistance. It also allows access to the adjustment accessible from the front and the upper sides. However, this solution which comprises an O-ring between the central core of the handle and the housing is only feasible on a limited number of moulded boxes, and imposes a knob diameter of 50mm minimum.

Example of aluminum enclosure with external knob, IP69K ingress protection



Enclosure with IP69K external thermostat knob

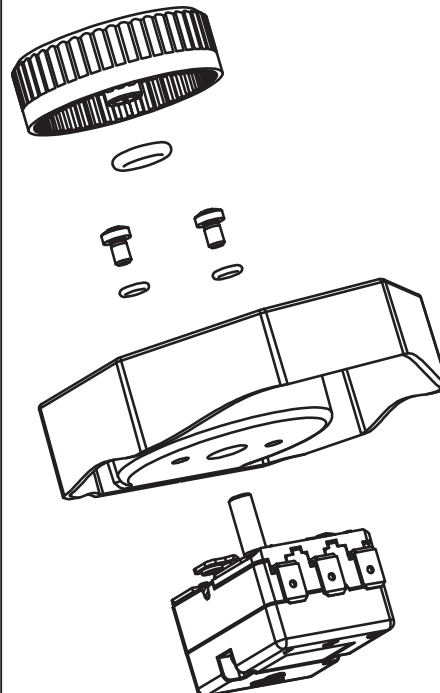
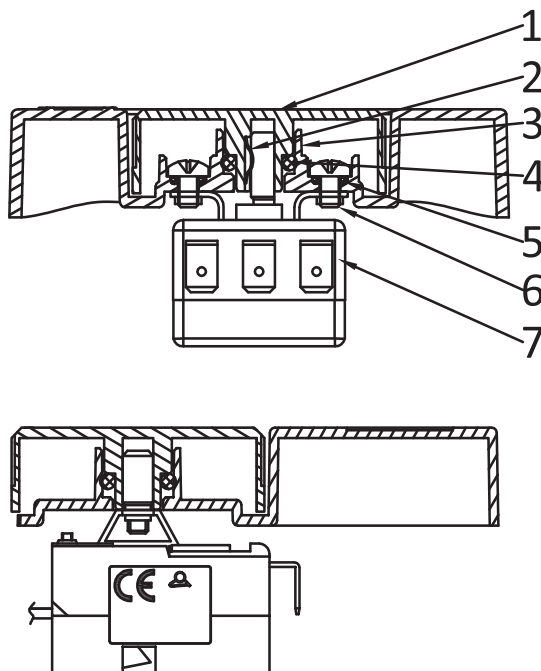

- 1: Graduated knob
- 2: Knob spring
- 3: O-ring gasket tubular seat
- 4: O-Ring
- 5: Mounting screws O-rings
- 6: Control mounting screws
- 7: Electro mechanical or electronic thermostat

Because of permanent improvement of our products, drawings, descriptions, features used on these data sheets are for guidance only and can be modified without prior advice















# Examples of mounting various devices in our immersion heater housings.



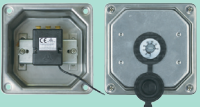
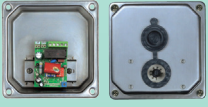

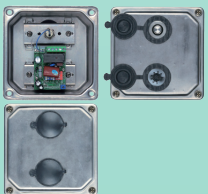
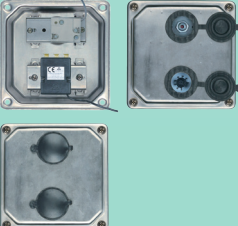







## Examples of mounting various devices in our immersion heater housings.

These products are not fully listed in this catalogue because the possibilities are endless. Our sales department and our engineering department will specifically answer your specifications.

<p>1</p> 	<p>Level switch with miniature connection box</p>	<p>2</p> 	<p>Level switch with miniature connection box, 16A 230V relay and pilot light</p>
<p>3</p> 	<p>Small temperature sensor with M8 thread inside miniature enclosure</p>	<p>4</p> 	<p>Temperature sensor with PTFE coated probe and PVDF enclosure, for corrosive liquids, with or without converter</p>
<p>5</p> 	<p>Single pole bulb and capillary thermostat inside round enclosure dia 86mm, inside adjustment under cap. <b>3 pole version is possible, but depends of length of heating elements inside</b></p>	<p>6</p> 	<p>Single pole bulb and capillary thermostat inside round enclosure dia 86mm, outside adjustment with knob. <b>3 pole version is possible, but depends of length of heating elements inside. IP40 only</b></p>
<p>7</p> 	<p><b>Single pole</b> bulb and capillary thermostat inside PA66 round enclosure dia. 86mm, external adjustment. <b>IP69K</b>. Compatible with M77 and 2"1/2 fittings. <b>Also available with internal adjustment under M25 screw cap.</b></p>	<p>8</p> 	<p><b>3 poles</b> bulb and capillary thermostat inside PA66 round enclosure dia. 86mm, external adjustment. <b>IP69K</b>. Compatible with M77 and 2"1/2 fittings. <b>Also available with internal adjustment under M25 screw cap.</b></p>
<p>9</p> 	<p>Single pole bulb and capillary thermostat inside stainless steel enclosure, inside adjustment Some models also available in <b>3 poles</b></p>	<p>10</p> 	<p><b>Single pole electronic</b> thermostat with remote sensor, inside stainless steel enclosure, internal adjustment. Center position on 105 x 105mm and 125 x 125mm position. Side position possible only on 125 x 125mm enclosure (NTC or Pt100 sensor)</p>
<p>11</p> 	<p>Single pole bulb and capillary manual reset <b>limiter</b> inside stainless steel enclosure, inside adjustment. Some models also available in <b>3 poles</b></p>	<p>12</p> 	<p>Single pole <b>electronic</b> manual reset <b>limiter</b> with remote sensor, inside stainless steel enclosure, internal adjustment and reset. (NTC or Pt100 sensor)</p>
<p>13</p> 	<p>Single pole bulb and capillary <b>thermostat</b> and manual reset <b>limiter</b> inside stainless steel enclosure, inside adjustment. Some models also available in <b>3 poles</b></p>	<p>14</p> 	<p>Single pole <b>electronic thermostat</b> and <b>manual reset limiter</b> with remote sensor, inside stainless steel enclosure, internal adjustment and reset. (NTC or Pt100 sensors)</p>

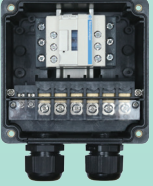
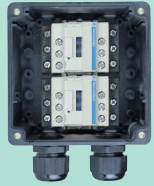
Because of permanent improvement of our products, drawings, descriptions, features used on these data sheets are for guidance only and can be modified without prior advice

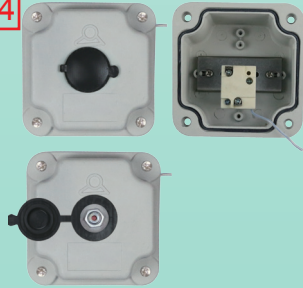
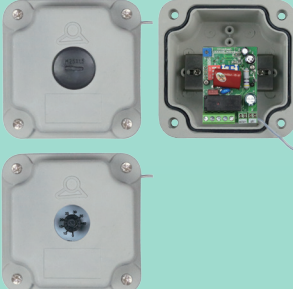









## Examples of mounting various devices in our immersion heater housings.

<p><b>15</b></p> 	<p>Single pole bulb and capillary thermostat inside round plastic enclosure in PA66, PP or PVDF. PC transparent cover only with PA66 body. No 3 poles versions</p>	<p><b>16</b></p> 	<p>Single pole remote sensor electronic thermostat inside round plastic enclosure in PA66, PP or PVDF. PC transparent cover only with PA66 body. No 3 poles versions. NTC or Pt100 sensors.</p>
<p><b>17</b></p> 	<p>Single pole bulb and capillary limiter with manual reset inside round plastic enclosure in PA66, PP or PVDF. PC transparent cover only with PA66 body. No 3 poles versions</p>	<p><b>18</b></p> 	<p>Single pole remote sensor electronic thermostat inside round plastic enclosure in PA66, PP or PVDF. PC transparent cover only with PA66 body. No 3 poles versions. NTC or Pt100 sensors.</p>
<p><b>19</b></p> 	<p>PA66 Plastic housing with one bulb and capillary adjustable thermostat and one fixed setting manual reset thermostat, access under screwed caps. No 3 poles versions.</p>	<p><b>20</b></p> 	<p>PA66 plastic housing with one bulb and capillary adjustable thermostat, one manual reset thermostat, 2 pilot lights and main switch, access from outside. Some models also available in 3 poles. Can also receive one or 2 power relays.</p>
<p><b>21</b></p> 	<p>PA66 plastic housing with 1 power relay on DIN rail and one connection block 10mm<sup>2</sup></p>	<p><b>22</b></p> 	<p>PA66 plastic housing with 2 power relays on DIN rail</p>
<p><b>23</b></p> 	<p>Aluminum enclosure with single pole bulb and capillary thermostat, internal adjustment under silicone boot. Also available with internal adjustment under PA66 screwed cap. Some models also available in 3 poles</p>	<p><b>24</b></p> 	<p>Aluminum enclosure with single pole manual reset bulb and capillary limiter. Internal reset under silicone boot. Also available with internal adjustment under PA66 screwed cap. Some models also available in 3 poles</p>
<p><b>25</b></p> 	<p>Aluminum enclosure with single pole electronic thermostat, NTC or Pt100 temperature sensor. Internal adjustment under silicone boot. Also available with internal adjustment under PA66 screwed cap. No 3 poles models.</p>	<p><b>26</b></p> 	<p>Small aluminum enclosure with single pole thermostat with external knob protected against shock, 2 pole main switch and pilot light. Also available with electronic thermostat.</p>

Because of permanent improvement of our products, drawings, descriptions, features used on these data sheets are for guidance only and can be modified without prior advice

## Examples of mounting various devices in our immersion heater housings.

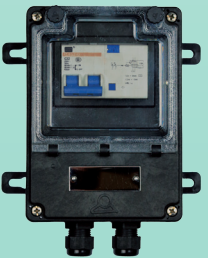
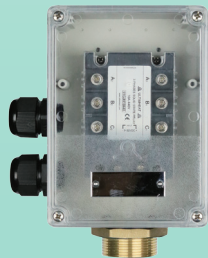
Because of permanent improvement of our products, drawings, descriptions, features used on these data sheets are for guidance only and can be modified without prior advice

<p><b>27</b></p> 	<p>Aluminum enclosure with <b>3 pole thermostat</b> with external knob protected against shock, internal access 3 pole manual reset (must remove cover for reset), 3 pole main switch and pilot light. Also available in single pole version.</p>	<p><b>28</b></p> 	<p>Stainless steel housing with <b>1 power relay</b> on DIN rail. Can also accept a single pole bulb and capillary <b>thermostat</b> or <b>limiter</b></p>
<p><b>29</b></p> 	<p>Stainless steel housing with <b>2 power relays</b> on DIN rail.</p>	<p><b>30</b></p> 	<p>PA66 Plastic housing with one bulb and capillary adjustable <b>thermostat</b>, access under clear PC window. Can also be added one fixed setting <b>manual reset thermostat</b> and <b>power relays</b>. Some models also available in <b>3 poles</b></p>
<p><b>31</b></p> 	<p>Plastic housing with one ON-OFF <b>electronic controller</b> with digital display, access under clear PC window. Can also be added one fixed setting manual reset thermostat and <b>power relays</b></p>	<p><b>32</b></p> 	<p>PA66 Plastic housing with one <b>PID electronic controller</b> with double digital display, access under clear PC window. Can also receive power relays or <b>SSR</b> output</p>
<p><b>33</b></p> 	<p>PA66 Plastic housing with <b>digital display electronic controller</b> on DIN rail, access under transparent cover.</p>	<p><b>34</b></p> 	<p>Aluminum housing with <b>1 power relay</b> and one connection block, access under clear PC window. Can also receive thermostat or <b>electronic controller</b> control panel.</p>
<p><b>35</b></p> 	<p>PA66 Plastic housing with residual current ground fault <b>breaker</b>, access under clear PC window. Compatible with most of European similar to Merlin Gerin Multi 9, C60 or VIGI C60. Maximum width 4 modules of 18mm.</p>	<p><b>36</b></p> 	<p>Aluminum enclosure with <b>heat exchanger fins</b>, fitted with one <b>3 pole solid state relay</b>.</p>
<p><b>37</b></p> 	<p>Aluminum enclosure with heat exchanger fins, fitted with <b>one to 4 single pole solid state relays</b>.</p>	<p><b>38</b></p> 	<p>Aluminum heat exchange finned enclosure, for assembly on backside of PA66 control enclosures, can receive <b>1 single pole solid state relay</b></p>





# **Deep drawn enclosure for moderately corrosive media, in stainless steel AISI 304 or AISI 316**

**Made of metal thickness 1mm, these enclosures provide a good compromise between impact resistance, weather resistance and chemicals.**

**They are non-flammable and have a maximum IP69K degree of ingress protection.**

**They can receive many accessories such as terminal blocks, DIN rails, and caps for settings. They are compatible with rotary or double-threaded fittings and some models can incorporate a fully-welded TIG stainless steel fitting for the production of all stainless steel immersion heaters for food or chemical use.**

**In standard, screws and fasteners are stainless steel.**

**In standard, gaskets are in silicone. They can be supplied in NBR or FKM (Viton) on request.**

**Red dimensions inside rectangular frames on drawings are used for accessories assembly.**



# Round miniature simplified immersion heater enclosure

Size(mm)	Volume(cm <sup>3</sup> )	Material	Protection grade		Model
<b>Dia. 54 x 50</b>	<b>105</b>	<b>stainless steel</b>	<b>IP69K</b>	<b>IK7</b>	<b>Y3K1</b>

## Suitable for

- Temperature sensor
- Immersion heater
- Finned heater
- Thermostat
- Level sensor
- Electronic board

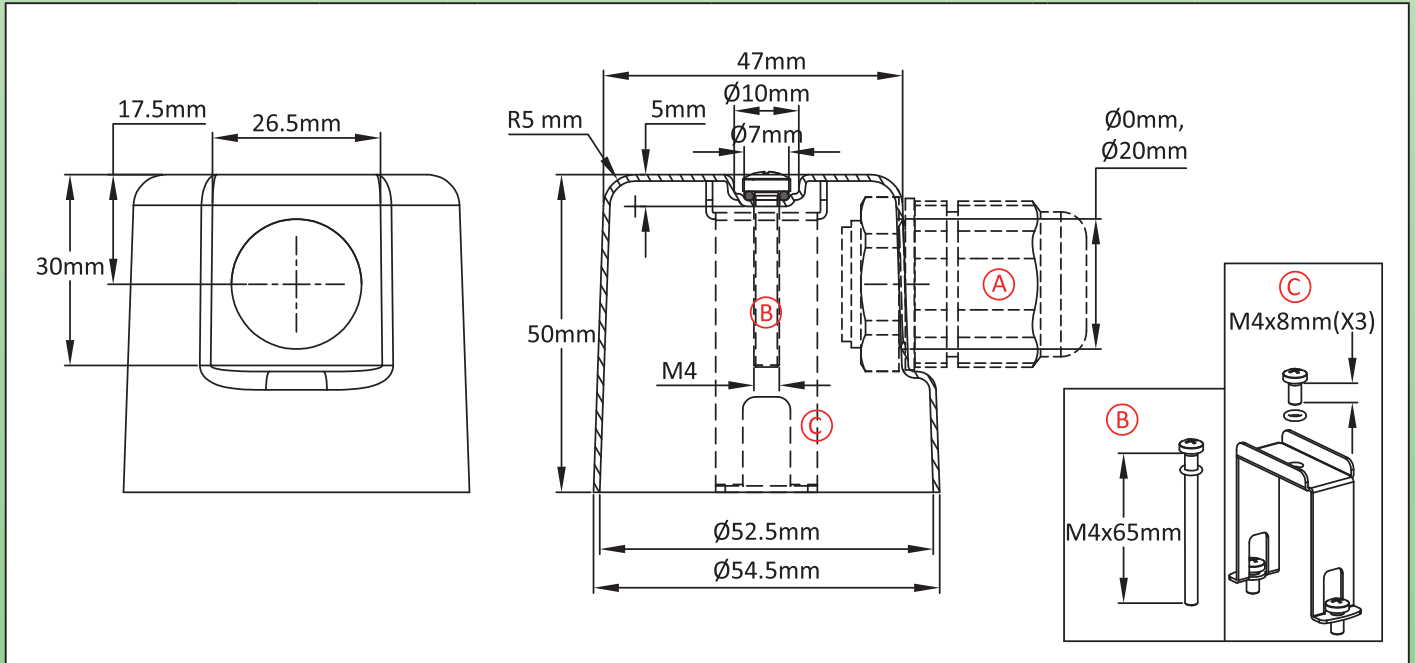

## Main references

Ⓐ(mm)	Ⓑ	Ⓒ	304	316
0	✓	×	Y3K1000100001008	Y3K1000100001009
20	✓	×	Y3K1000112001008	Y3K1000112001009
0	×	✓	Y3K10001000E1008	Y3K10001000E1009
20	×	✓	Y3K10001120E1008	Y3K10001120E1009
0	×	×	Y3K1000100000008	Y3K1000100000009
20	×	×	Y3K1000112000008	Y3K1000112000009

## Links

	Page (.pdf)
	Drawing 2D (.dwg)
	Drawing 3D (.stp)

Cable gland not included in these reference, consult us if you want them.

Red dimensions inside rectangular frames are used for accessories assembly.

Because of permanent improvement of our products, drawings, descriptions, features used on these data sheets are for guidance only and can be modified without prior advice

# Round, large diameter, simplified immersion heater enclosure

Size(mm)	Volume(cm <sup>3</sup> )	Material	Protection grade		Model
Dia. 86 x 72	390	stainless steel	IP69K	IK7	<b>Y3K2</b>

## Suitable for

- Temperature sensor
- Immersion heater
- Finned heater
- Thermostat
- Level sensor
- Electronic board

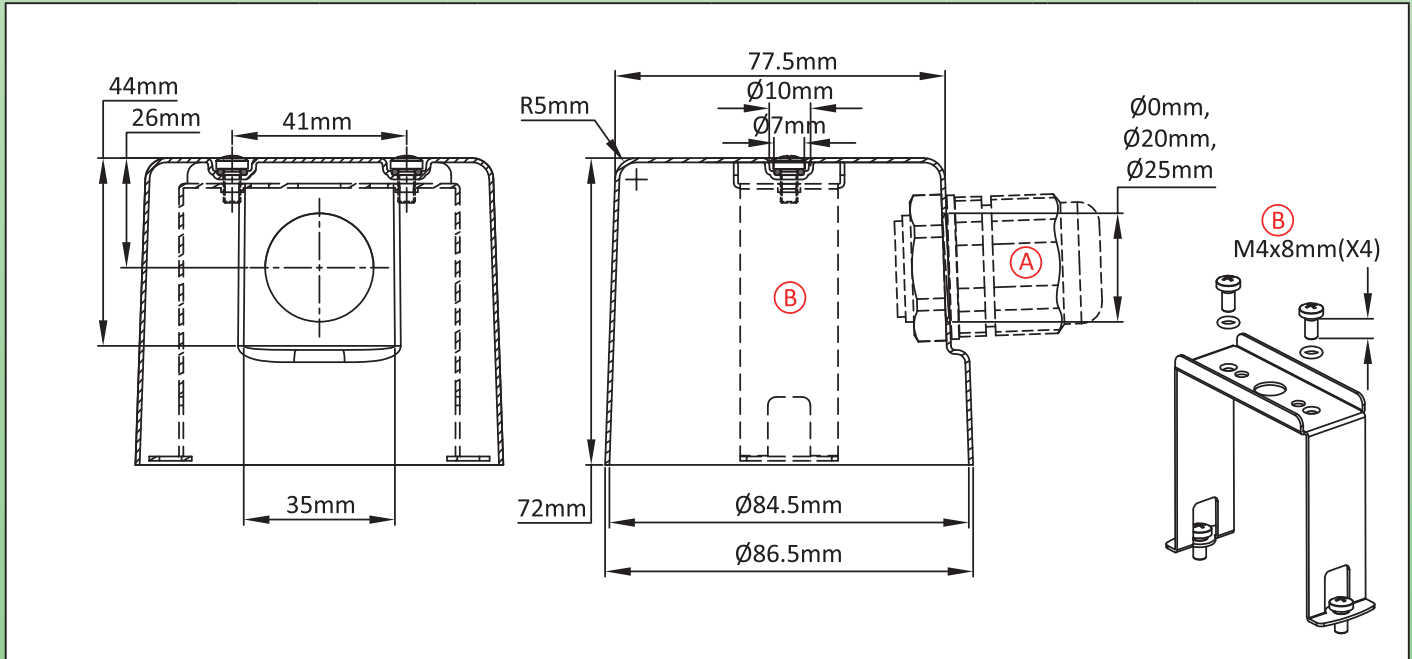

## Main references

(A)(mm)	(B)	304	316
0	✓	Y3K20001000E2008	Y3K20001000E2009
20	✓	Y3K20001120E2008	Y3K20001120E2009
25	✓	Y3K20001125E2008	Y3K20001125E2009
0	✗	Y3K2000100000008	Y3K2000100000009
20	✗	Y3K2000112000008	Y3K2000112000009
25	✗	Y3K2000112500008	Y3K2000112500009

## Links

	Page (.pdf)
	Drawing 2D (.dwg)
	Drawing 3D (.stp)

Cable gland not included in these reference, consult us if you want them.

Red dimensions inside rectangular frames are used for accessories assembly.



## Miniature enclosure for temperature sensor or level sensor

Size(mm)	Volume(cm <sup>3</sup> )	Material	Protection grade		Model
<b>75 × 60 × 44</b>	<b>111</b>	<b>stainless steel</b>	<b>IP69K</b>	<b>IK7</b>	<b>Y3L1</b>

### Suitable for

- Temperature sensor
- Immersion heater
- Finned heater
- Thermostat
- Level sensor
- Electronic board

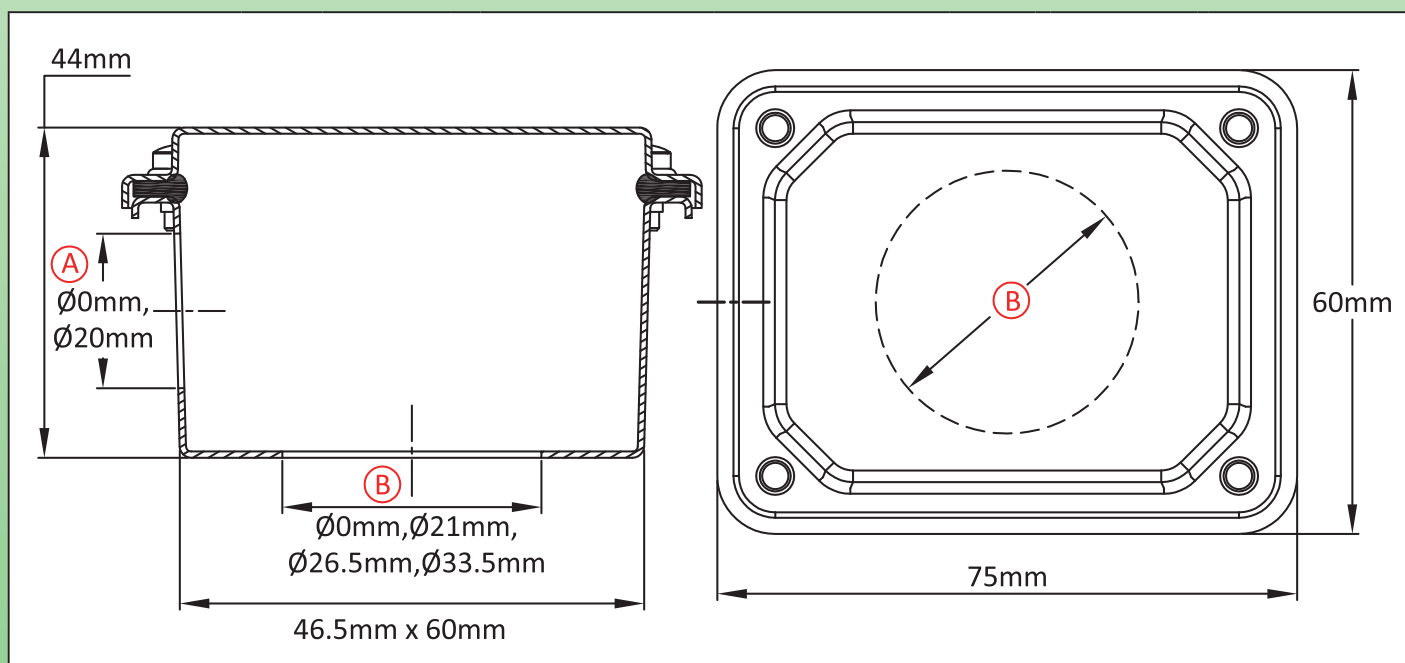

### Main references

(A)(mm)	(B)(mm)	304	316
0	0	Y3L1000000000008	Y3L1000000000009
0	21	Y3L1210000000008	Y3L1210000000009
0	26.5	Y3L1265000000008	Y3L1265000000009
0	33.5	Y3L1335000000008	Y3L1335000000009
20	0	Y3L1000120000008	Y3L1000120000009
20	21	Y3L1210120000008	Y3L1210120000009
20	26.5	Y3L1265120000008	Y3L1265120000009
20	33.5	Y3L1335120000008	Y3L1335120000009

### Links

	Page (.pdf)
	Drawing 2D (.dwg)
	Drawing 3D (.stp)

Cable gland not included in these reference, consult us if you want them.

Red dimensions inside rectangular frames are used for accessories assembly.

## Miniature enclosure for temperature sensor or level sensor

Size(mm)	Volume(cm <sup>3</sup> )	Material	Protection grade		Model
<b>75 × 60 × 52</b>	<b>119</b>	<b>stainless steel</b>	<b>IP69K</b>	<b>IK7</b>	<b>Y3L2</b>

### Suitable for

- Temperature sensor
- Immersion heater
- Finned heater
- Thermostat
- Level sensor
- Electronic board

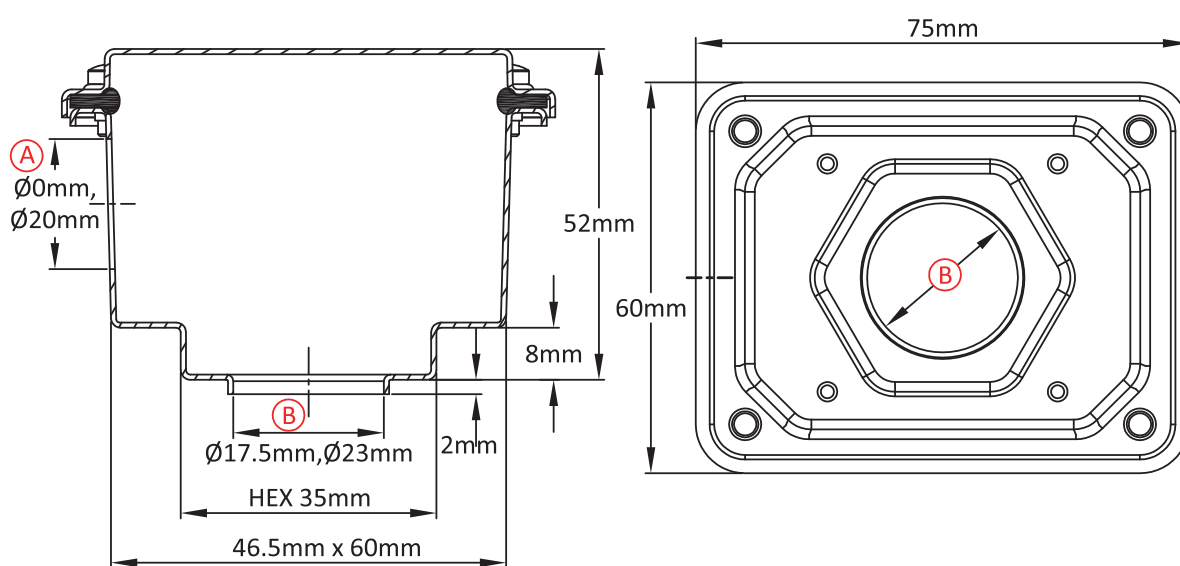

### Main references

Ⓐ(mm)	Ⓑ(mm)	304	316
0	17.5	Y3L2175000000008	Y3L2175000000009
0	23	Y3L2230000000008	Y3L2230000000009
20	17.5	Y3L2175120000008	Y3L2175120000009
20	23	Y3L2230120000008	Y3L2230120000009

### Links

	Page (.pdf)
	Drawing 2D (.dwg)
	Drawing 3D (.stp)

Cable gland not included in these reference, consult us if you want them.

Red dimensions inside rectangular frames are used for accessories assembly.

## Miniature enclosure for immersion heater, temperature sensor or level sensor

Size(mm)	Volume(cm <sup>3</sup> )	Material	Protection grade		Model
90 × 90 × 45	206	stainless steel	IP69K	IK7	<b>Y3L3</b>

### Suitable for

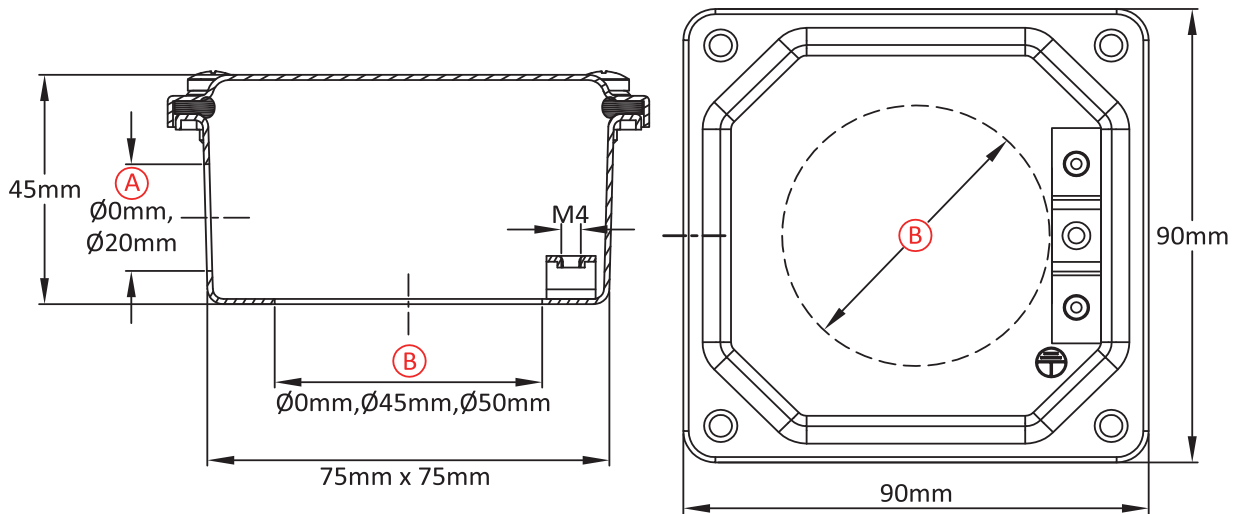

- Temperature sensor
- Immersion heater
- Finned heater
- Thermostat
- Level sensor
- Electronic board



### Main references

Ⓐ(mm)	Ⓑ(mm)	304	316
0	0	Y3L3000000000008	Y3L3000000000009
0	45	Y3L3450000000008	Y3L3450000000009
0	50	Y3L3500000000008	Y3L3500000000009
20	0	Y3L3000120000008	Y3L3000120000009
20	45	Y3L3450120000008	Y3L3450120000009
20	50	Y3L3500120000008	Y3L3500120000009

### Links

	Page (.pdf)
	Drawing 2D (.dwg)
	Drawing 3D (.stp)

Cable gland not included in these reference, consult us if you want them.

Red dimensions inside rectangular frames are used for accessories assembly.

## Enclosure for small storage heater immersion heater

Size(mm)	Volume(cm <sup>3</sup> )	Material	Protection grade		Model
<b>90 × 90 × 52</b>	<b>232</b>	<b>stainless steel</b>	<b>IP69K</b>	<b>IK7</b>	<b>Y3L4</b>

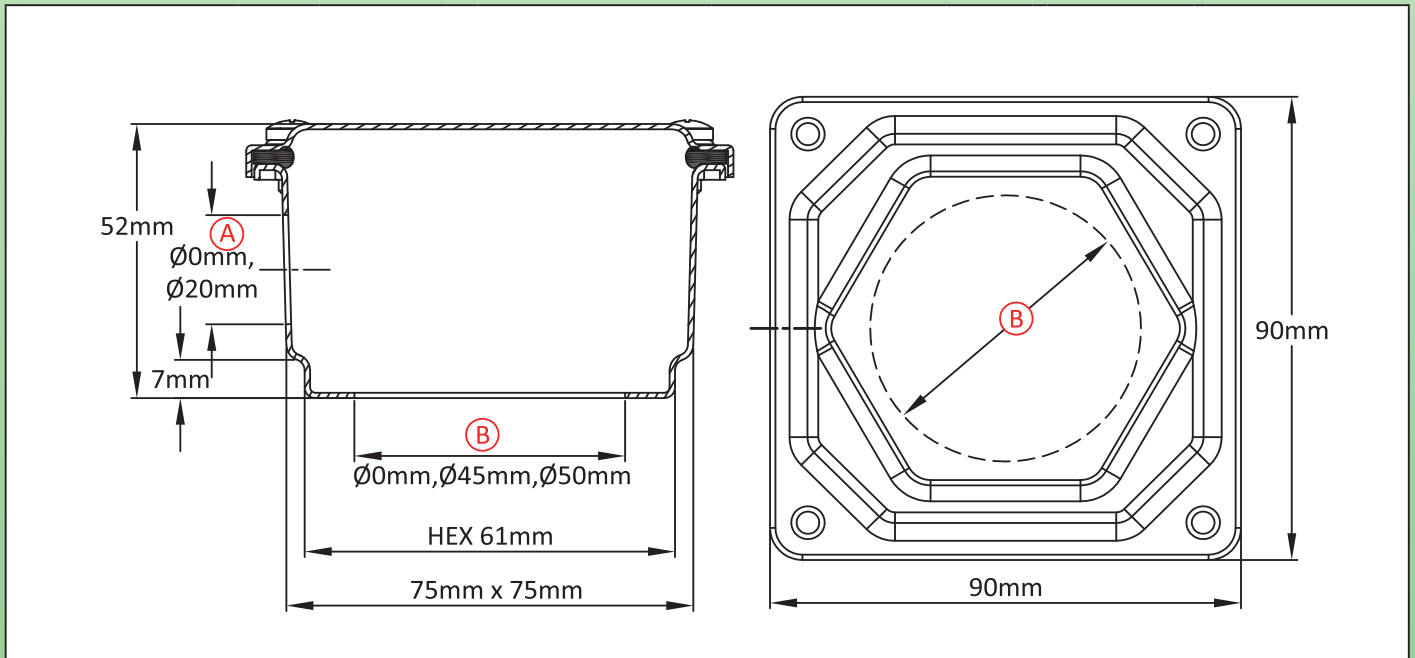

Suitable for
<input type="checkbox"/> Temperature sensor
<input checked="" type="checkbox"/> Immersion heater
<input type="checkbox"/> Finned heater
<input type="checkbox"/> Thermostat
<input type="checkbox"/> Level sensor
<input type="checkbox"/> Electronic board



### Main references

Ⓐ(mm)	Ⓑ(mm)	304	316
0	0	Y3L4000000000008	Y3L4000000000009
0	45	Y3L4450000000008	Y3L4450000000009
0	50	Y3L4500000000008	Y3L4500000000009
20	0	Y3L4000120000008	Y3L4000120000009
20	45	Y3L4450120000008	Y3L4450120000009
20	50	Y3L4500120000008	Y3L4500120000009

### Links

	Page (.pdf)
	Drawing 2D (.dwg)
	Drawing 3D (.stp)

Cable gland not included in these reference, consult us if you want them.

Red dimensions inside rectangular frames are used for accessories assembly.

## Immersion heater or temperature sensor enclosure

Size(mm)	Volume(cm <sup>3</sup> )	Material	Protection grade		Model
<b>90 × 90 × 75</b>	<b>392</b>	<b>stainless steel</b>	<b>IP69K</b>	<b>IK7</b>	<b>Y3S3</b>

### Suitable for

- Temperature sensor
- Immersion heater
- Finned heater
- Thermostat
- Level sensor
- Electronic board

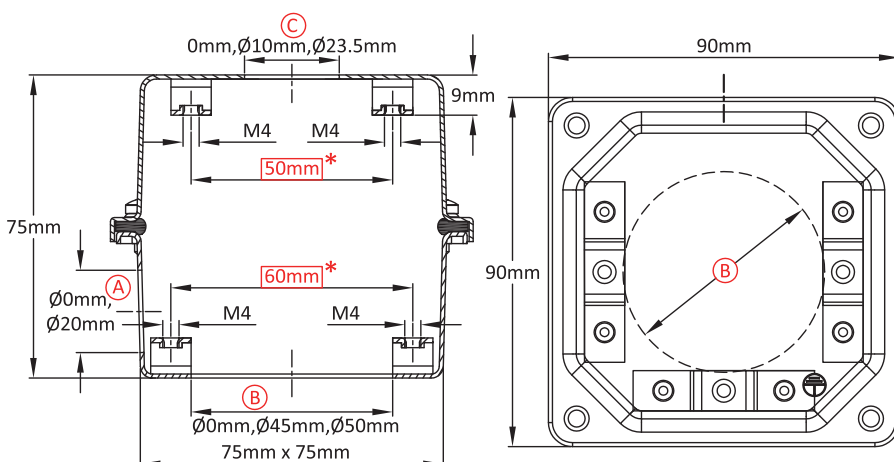

### Links



Page  
(.pdf)



Drawing 2D  
(.dwg)



Drawing 3D  
(.stp)

### Main references

(A) (mm)	(B) (mm)	(C) (mm)	304	316	(A) (mm)	(B) (mm)	(C) (mm)	304	316
0	0	0	Y3S3000000G1008	Y3S3000000G1009	20	0	0	Y3S30000120G1008	Y3S30000120G1009
0	0	10	Y3S3000A000G1008	Y3S3000A000G1009	20	0	10	Y3S3000A120G1008	Y3S3000A120G1009
0	0	23.5	Y3S3000D000G1008	Y3S3000D000G1009	20	0	23.5	Y3S3000D120G1008	Y3S3000D120G1009
0	45	0	Y3S3450000G1008	Y3S3450000G1009	20	45	0	Y3S34500120G1008	Y3S34500120G1009
0	45	10	Y3S3450A000G1008	Y3S3450A000G1009	20	45	10	Y3S3450A120G1008	Y3S3450A120G1009
0	45	23.5	Y3S3450D000G1008	Y3S3450D000G1009	20	45	23.5	Y3S3450D120G1008	Y3S3450D120G1009
0	50	0	Y3S3500000G1008	Y3S3500000G1009	20	50	0	Y3S35000120G1008	Y3S35000120G1009
0	50	10	Y3S3500A000G1008	Y3S3500A000G1009	20	50	10	Y3S3500A120G1008	Y3S3500A120G1009
0	50	23.5	Y3S3500D000G1008	Y3S3500D000G1009	20	50	23.5	Y3S3500D120G1008	Y3S3500D120G1009

Cable gland not included in these reference, consult us if you want them.

Red dimensions inside rectangular frames are used for accessories assembly.

# Immersion heater enclosure with built-in hexagon for fitting

Size(mm)	Volume(cm <sup>3</sup> )	Material	Protection grade		Model
<b>90 × 90 × 82</b>	<b>418</b>	<b>stainless steel</b>	<b>IP69K</b>	<b>IK7</b>	<b>Y3S4</b>

Suitable for
<input type="checkbox"/> Temperature sensor
<input checked="" type="checkbox"/> Immersion heater
<input type="checkbox"/> Finned heater
<input checked="" type="checkbox"/> Thermostat
<input type="checkbox"/> Level sensor
<input checked="" type="checkbox"/> Electronic board

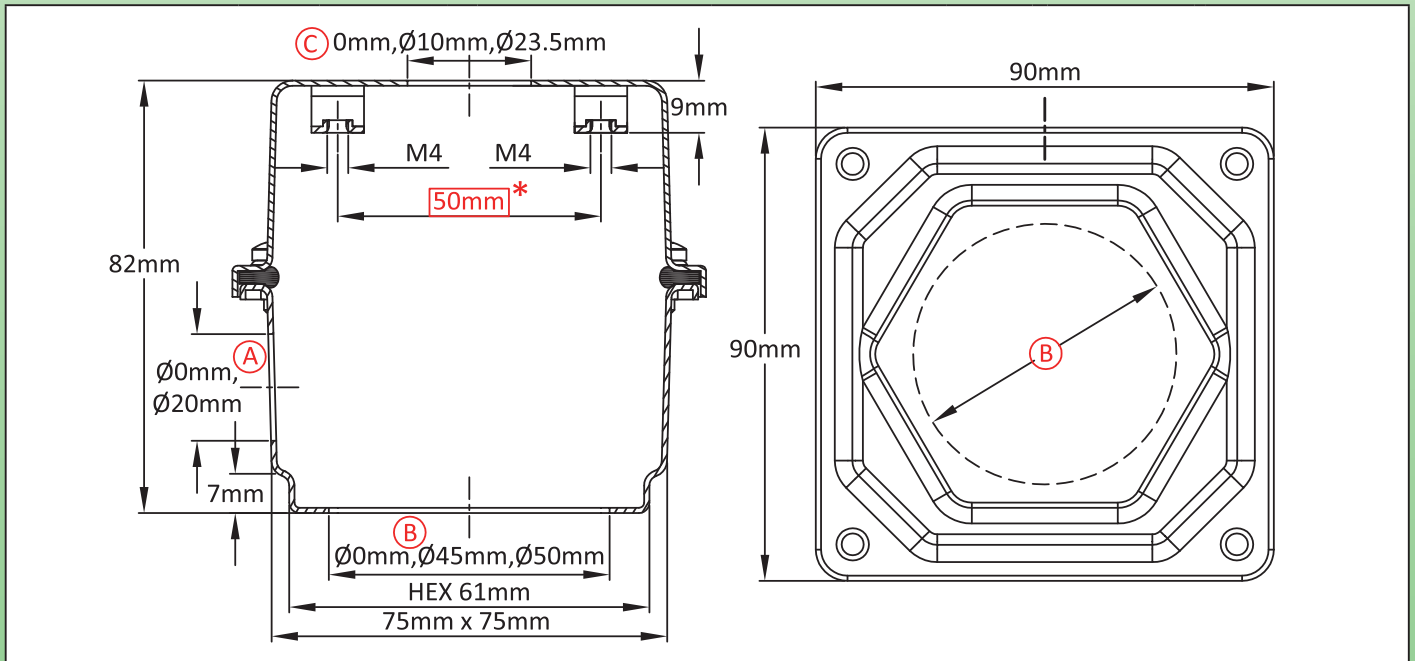

## Main references

			304	316				304	316
(A) (mm)	(B) (mm)	(C) (mm)			(A) (mm)	(B) (mm)	(C) (mm)		
0	0	0	Y3S4000000G1008	Y3S4000000G1009	20	0	0	Y3S40000120G1008	Y3S40000120G1009
0	0	10	Y3S4000A000G1008	Y3S4000A000G1009	20	0	10	Y3S4000A120G1008	Y3S4000A120G1009
0	0	23.5	Y3S4000D000G1008	Y3S4000D000G1009	20	0	23.5	Y3S4000D120G1008	Y3S4000D120G1009
0	45	0	Y3S44500000G1008	Y3S44500000G1009	20	45	0	Y3S44500120G1008	Y3S44500120G1009
0	45	10	Y3S4450A000G1008	Y3S4450A000G1009	20	45	10	Y3S4450A120G1008	Y3S4450A120G1009
0	45	23.5	Y3S4450D000G1008	Y3S4450D000G1009	20	45	23.5	Y3S4450D120G1008	Y3S4450D120G1009
0	50	0	Y3S45000000G1008	Y3S45000000G1009	20	50	0	Y3S45000120G1008	Y3S45000120G1009
0	50	10	Y3S4500A000G1008	Y3S4500A000G1009	20	50	10	Y3S4500A120G1008	Y3S4500A120G1009
0	50	23.5	Y3S4500D000G1008	Y3S4500D000G1009	20	50	23.5	Y3S4500D120G1008	Y3S4500D120G1009

## Links

Page  
(.pdf)

Drawing  
2D  
(.dwg)

Drawing  
3D  
(.stp)

Cable gland not included in these reference, consult us if you want them.  
Red dimensions inside rectangular frames are used for accessories assembly.

# Medium size enclosure for immersion heater or temperature sensor



Size(mm)	Volume(cm <sup>3</sup> )	Material	Protection grade		Model
105 × 105 × 102	757	stainless steel	IP69K	IK7	<b>Y3S5</b>

### Suitable for

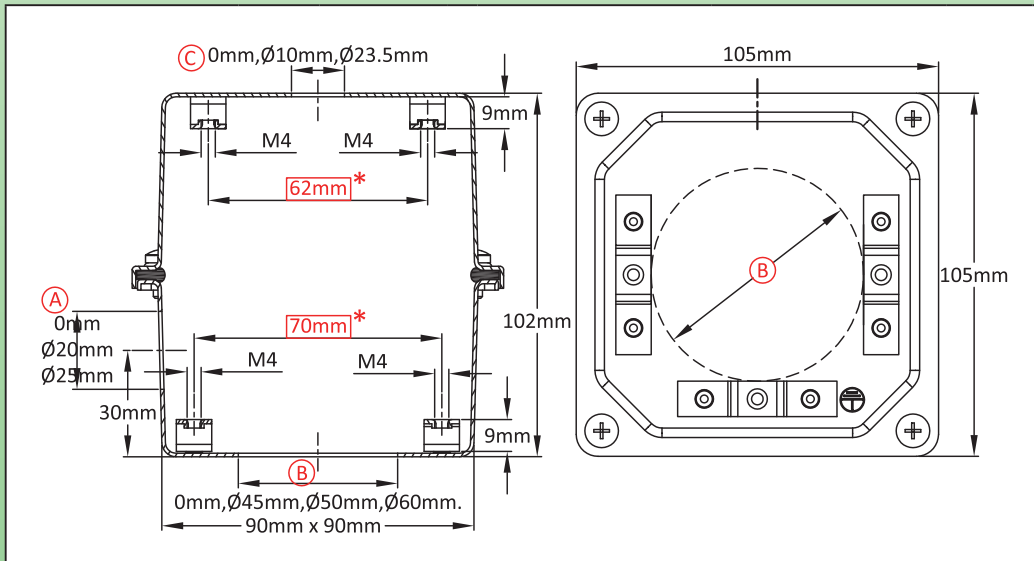
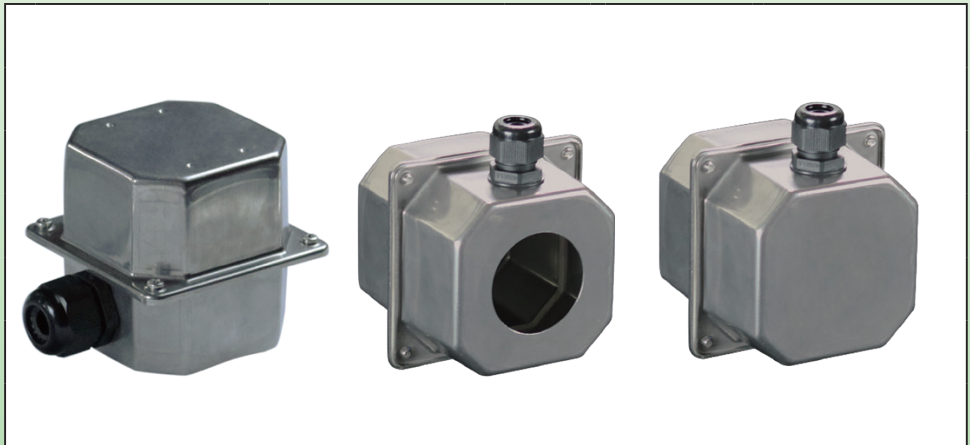
- Temperature sensor
- Immersion heater
- Finned heater
- Thermostat
- Level sensor
- Electronic board



### Links

-  [Page \(.pdf\)](#)
-  [Drawing 2D \(.dwg\)](#)
-  [Drawing 3D \(.stp\)](#)

### Main references

A (mm)	B (mm)	C (mm)	304	316	A (mm)	B (mm)	C (mm)	304	316	A (mm)	B (mm)	C (mm)	304	316
0	0	0	Y3S5000000G1008	Y3S5000000G1009	20	0	0	Y3S50000120G1008	Y3S50000120G1009	25	0	0	Y3S50000125G1008	Y3S50000125G1009
0	0	10	Y3S5000A000G1008	Y3S5000A000G1009	20	0	10	Y3S5000A120G1008	Y3S5000A120G1009	25	0	10	Y3S5000A125G1008	Y3S5000A125G1009
0	0	23.5	Y3S5000D000G1008	Y3S5000D000G1009	20	0	23.5	Y3S5000D120G1008	Y3S5000D120G1009	25	0	23.5	Y3S5000D125G1008	Y3S5000D125G1009
0	45	0	Y3S5450000G1008	Y3S5450000G1009	20	45	0	Y3S54500120G1008	Y3S54500120G1009	25	45	0	Y3S54500125G1008	Y3S54500125G1009
0	45	10	Y3S5450A000G1008	Y3S5450A000G1009	20	45	10	Y3S5450A120G1008	Y3S5450A120G1009	25	45	10	Y3S5450A125G1008	Y3S5450A125G1009
0	45	23.5	Y3S5450D000G1008	Y3S5450D000G1009	20	45	23.5	Y3S5450D120G1008	Y3S5450D120G1009	25	45	23.5	Y3S5450D125G1008	Y3S5450D125G1009
0	50	0	Y3S5500000G1008	Y3S5500000G1009	20	50	0	Y3S55000120G1008	Y3S55000120G1009	25	50	0	Y3S55000125G1008	Y3S55000125G1009
0	50	10	Y3S5500A000G1008	Y3S5500A000G1009	20	50	10	Y3S5500A120G1008	Y3S5500A120G1009	25	50	10	Y3S5500A125G1008	Y3S5500A125G1009
0	50	23.5	Y3S5500D000G1008	Y3S5500D000G1009	20	50	23.5	Y3S5500D120G1008	Y3S5500D120G1009	25	50	23.5	Y3S5500D125G1008	Y3S5500D125G1009
0	60	0	Y3S5600000G1008	Y3S5600000G1009	20	60	0	Y3S56000120G1008	Y3S56000120G1009	25	60	0	Y3S56000125G1008	Y3S56000125G1009
0	60	10	Y3S5600A000G1008	Y3S5600A000G1009	20	60	10	Y3S5600A120G1008	Y3S5600A120G1009	25	60	10	Y3S5600A125G1008	Y3S5600A125G1009
0	60	23.5	Y3S5600D000G1008	Y3S5600D000G1009	20	60	23.5	Y3S5600D120G1008	Y3S5600D120G1009	25	60	23.5	Y3S5600D125G1008	Y3S5600D125G1009

Cable gland not included in these reference, consult us if you want them.

Red dimensions inside rectangular frames are used for accessories assembly.

Because of permanent improvement of our products, drawings, descriptions, features used on these data sheets are for guidance only and can be modified without prior advice

# Medium size immersion heater enclosure with built-in hexagon for fitting

Size(mm)	Volume(cm <sup>3</sup> )	Material	Protection grade		Model
<b>105 × 105 × 110</b>	<b>781</b>	<b>stainless steel</b>	<b>IP69K</b>	<b>IK7</b>	<b>Y3S6</b>

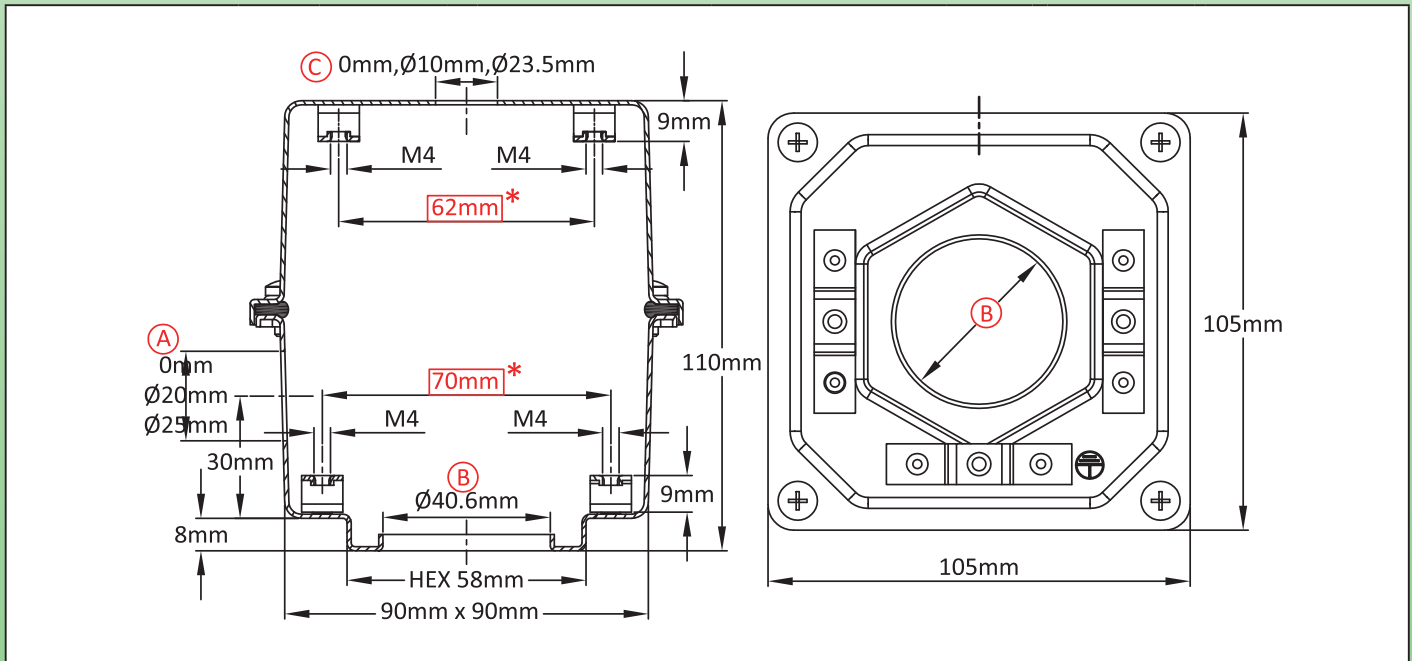

Suitable for
<input type="checkbox"/> Temperature sensor
<input checked="" type="checkbox"/> Immersion heater
<input type="checkbox"/> Finned heater
<input checked="" type="checkbox"/> Thermostat
<input type="checkbox"/> Level sensor
<input checked="" type="checkbox"/> Electronic board



## Main references

(A)(mm)	(B)(mm)	(C)(mm)	304	316
0	40.6	0	Y3S64060000G1008	Y3S64060000G1009
0	40.6	10	Y3S6406A000G1008	Y3S6406A000G1009
0	40.6	23.5	Y3S6406D000G1008	Y3S6406D000G1009
20	40.6	0	Y3S64060120G1008	Y3S64060120G1009
20	40.6	10	Y3S6406A120G1008	Y3S6406A120G1009
20	40.6	23.5	Y3S6406D120G1008	Y3S6406D120G1009
25	40.6	0	Y3S64060125G1008	Y3S64060125G1009
25	40.6	10	Y3S6406A125G1008	Y3S6406A125G1009
25	40.6	23.5	Y3S6406D125G1008	Y3S6406D125G1009

## Links

	Page (.pdf)
	Drawing 2D (.dwg)
	Drawing 3D (.stp)

Cable gland not included in these reference, consult us if you want them.

Red dimensions inside rectangular frames are used for accessories assembly.



## Immersion heater or temperature sensor, flat cover

Size(mm)	Volume(cm <sup>3</sup> )	Material	Protection grade		Model
<b>125 × 125 × 85</b>	<b>970</b>	<b>stainless steel</b>	<b>IP69K</b>	<b>IK7</b>	<b>Y3SA</b>

Suitable for
<input type="checkbox"/> Temperature sensor
<input checked="" type="checkbox"/> Immersion heater
<input checked="" type="checkbox"/> Finned heater
<input checked="" type="checkbox"/> Thermostat
<input type="checkbox"/> Level sensor
<input checked="" type="checkbox"/> Electronic board

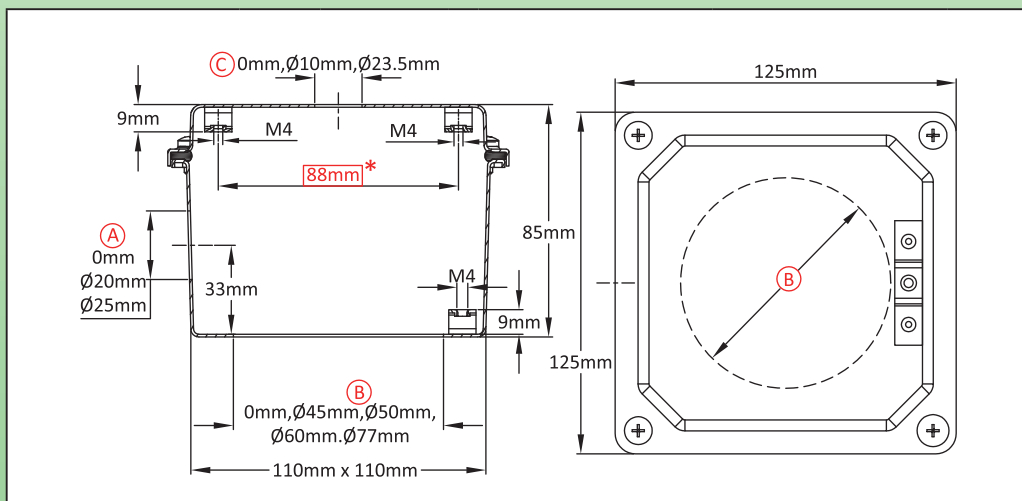

### Links

	Page (.pdf)
	Drawing 2D (.dwg)
	Drawing 3D (.stp)

### Main references

(A) (mm)	(B) (mm)	(C) (mm)	304	316	(A) (mm)	(B) (mm)	(C) (mm)	304	316	(A) (mm)	(B) (mm)	(C) (mm)	304	316
0	0	0	Y3SA0000000G1008	Y3SA0000000G1009	20	0	0	Y3SA0000120G1008	Y3SA0000120G1009	25	0	0	Y3SA0000125G1008	Y3SA0000125G1009
0	0	10	Y3SA000A000G1008	Y3SA000A000G1009	20	0	10	Y3SA000A120G1008	Y3SA000A120G1009	25	0	10	Y3SA000A125G1008	Y3SA000A125G1009
0	0	23.5	Y3SA000D000G1008	Y3SA000D000G1009	20	0	23.5	Y3SA000D120G1008	Y3SA000D120G1009	25	0	23.5	Y3SA000D125G1008	Y3SA000D125G1009
0	45	0	Y3SA4500000G1008	Y3SA4500000G1009	20	45	0	Y3SA4500120G1008	Y3SA4500120G1009	25	45	0	Y3SA4500125G1008	Y3SA4500125G1009
0	45	10	Y3SA450A000G1008	Y3SA450A000G1009	20	45	10	Y3SA450A120G1008	Y3SA450A120G1009	25	45	10	Y3SA450A125G1008	Y3SA450A125G1009
0	45	23.5	Y3SA450D000G1008	Y3SA450D000G1009	20	45	23.5	Y3SA450D120G1008	Y3SA450D120G1009	25	45	23.5	Y3SA450D125G1008	Y3SA450D125G1009
0	50	0	Y3SA5000000G1008	Y3SA5000000G1009	20	50	0	Y3SA5000120G1008	Y3SA5000120G1009	25	50	0	Y3SA5000125G1008	Y3SA5000125G1009
0	50	10	Y3SA500A000G1008	Y3SA500A000G1009	20	50	10	Y3SA500A120G1008	Y3SA500A120G1009	25	50	10	Y3SA500A125G1008	Y3SA500A125G1009
0	50	23.5	Y3SA500D000G1008	Y3SA500D000G1009	20	50	23.5	Y3SA500D120G1008	Y3SA500D120G1009	25	50	23.5	Y3SA500D125G1008	Y3SA500D125G1009
0	60	0	Y3SA6000000G1008	Y3SA6000000G1009	20	60	0	Y3SA6000120G1008	Y3SA6000120G1009	25	60	0	Y3SA6000125G1008	Y3SA6000125G1009
0	60	10	Y3SA600A000G1008	Y3SA600A000G1009	20	60	10	Y3SA600A120G1008	Y3SA600A120G1009	25	60	10	Y3SA600A125G1008	Y3SA600A125G1009
0	60	23.5	Y3SA600D000G1008	Y3SA600D000G1009	20	60	23.5	Y3SA600D120G1008	Y3SA600D120G1009	25	60	23.5	Y3SA600D125G1008	Y3SA600D125G1009
0	77	0	Y3SA7700000G1008	Y3SA7700000G1009	20	77	0	Y3SA7700120G1008	Y3SA7700120G1009	25	77	0	Y3SA7700125G1008	Y3SA7700125G1009
0	77	10	Y3SA770A000G1008	Y3SA770A000G1009	20	77	10	Y3SA770A120G1008	Y3SA770A120G1009	25	77	10	Y3SA770A125G1008	Y3SA770A125G1009
0	77	23.5	Y3SA770D000G1008	Y3SA770D000G1009	20	77	23.5	Y3SA770D120G1008	Y3SA770D120G1009	25	77	23.5	Y3SA770D125G1008	Y3SA770D125G1009

Cable gland not included in these reference, consult us if you want them.

Red dimensions inside rectangular frames are used for accessories assembly.

Because of permanent improvement of our products, drawings, descriptions, features used on these data sheets are for guidance only and can be modified without prior advice

# Big immersion heater enclosure, with flat cover and stamped hexagon

Size(mm)	Volume(cm <sup>3</sup> )	Material	Protection grade		Model
125 × 125 × 93	1000	stainless steel	IP69K	IK7	<b>Y3SB</b>

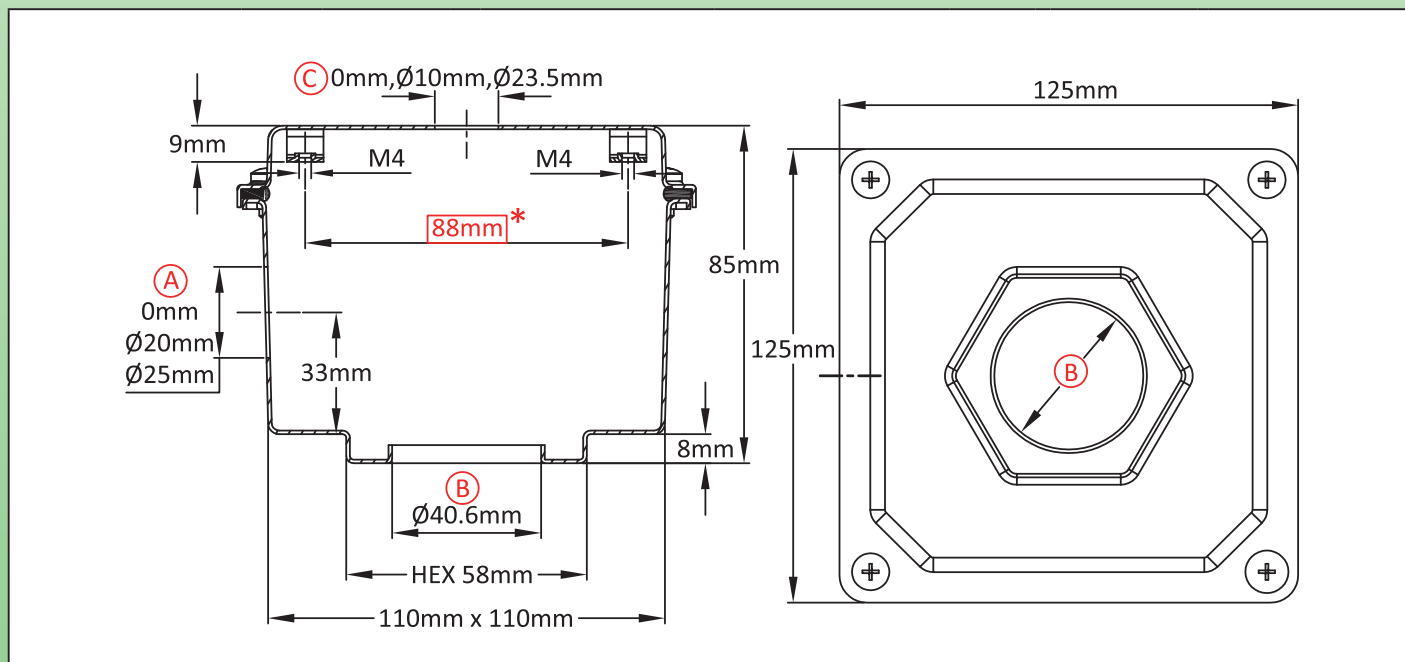

Suitable for
<input type="checkbox"/> Temperature sensor
<input checked="" type="checkbox"/> Immersion heater
<input type="checkbox"/> Finned heater
<input checked="" type="checkbox"/> Thermostat
<input type="checkbox"/> Level sensor
<input checked="" type="checkbox"/> Electronic board



## Main references

(A)(mm)	(B)(mm)	(C)(mm)	304	316
0	40.6	0	Y3SB4060000G1008	Y3SB4060000G1009
0	40.6	10	Y3SB406A000G1008	Y3SB406A000G1009
0	40.6	23.5	Y3SB406D000G1008	Y3SB406D000G1009
20	40.6	0	Y3SB4060120G1008	Y3SB4060120G1009
20	40.6	10	Y3SB406A120G1008	Y3SB406A120G1009
20	40.6	23.5	Y3SB406D120G1008	Y3SB406D120G1009
25	40.6	0	Y3SB4060125G1008	Y3SB4060125G1009
25	40.6	10	Y3SB406A125G1008	Y3SB406A125G1009
25	40.6	23.5	Y3SB406D125G1008	Y3SB406D125G1009

## Links

	Page (.pdf)
	Drawing 2D (.dwg)
	Drawing 3D (.stp)

Cable gland not included in these reference, consult us if you want them.

Red dimensions inside rectangular frames are used for accessories assembly.

# Big immersion heater enclosure, with flat cover and stamped hexagon, for big immersion heaters

Size(mm)	Volume(cm <sup>3</sup> )	Material	Protection grade		Model
125 × 125 × 85	1000	stainless steel	IP69K	IK7	<b>Y3SC</b>

## Suitable for

- Temperature sensor
- Immersion heater
- Finned heater
- Thermostat
- Level sensor
- Electronic board

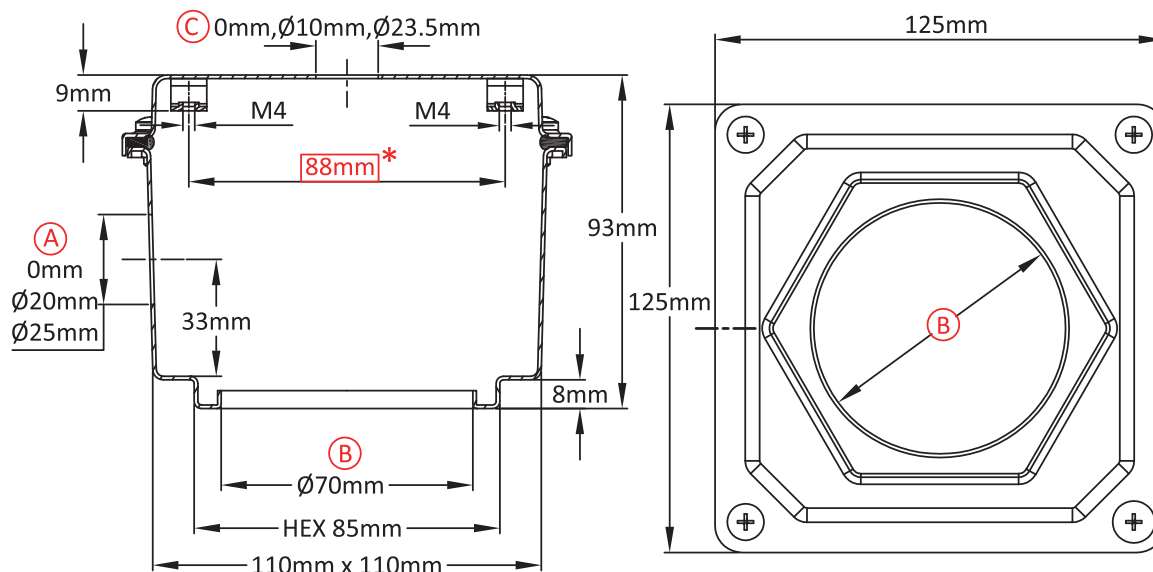

## Main references

(A)(mm)	(B)(mm)	(C)(mm)	304	316
0	70	0	Y3SC7000000G1008	Y3SC7000000G1009
0	70	10	Y3SC700A000G1008	Y3SC700A000G1009
0	70	23.5	Y3SC700D000G1008	Y3SC700D000G1009
20	70	0	Y3SC7000120G1008	Y3SC7000120G1009
20	70	10	Y3SC700A120G1008	Y3SC700A120G1009
20	70	23.5	Y3SC700D120G1008	Y3SC700D120G1009
25	70	0	Y3SC7000125G1008	Y3SC7000125G1009
25	70	10	Y3SC700A125G1008	Y3SC700A125G1009
25	70	23.5	Y3SC700D125G1008	Y3SC700D125G1009

## Links

	Page (.pdf)
	Drawing 2D (.dwg)
	Drawing 3D (.stp)

Cable gland not included in these reference, consult us if you want them.

Red dimensions inside rectangular frames are used for accessories assembly.

## Big enclosure, for immersion heaters or instruments, with flat cover, for welding on tubes

Size(mm)	Volume(cm <sup>3</sup> )	Material	Protection grade		Model
<b>125 × 125 × 105</b>	<b>1138</b>	<b>stainless steel</b>	<b>IP69K</b>	<b>IK7</b>	<b>Y3TB</b>

### Suitable for

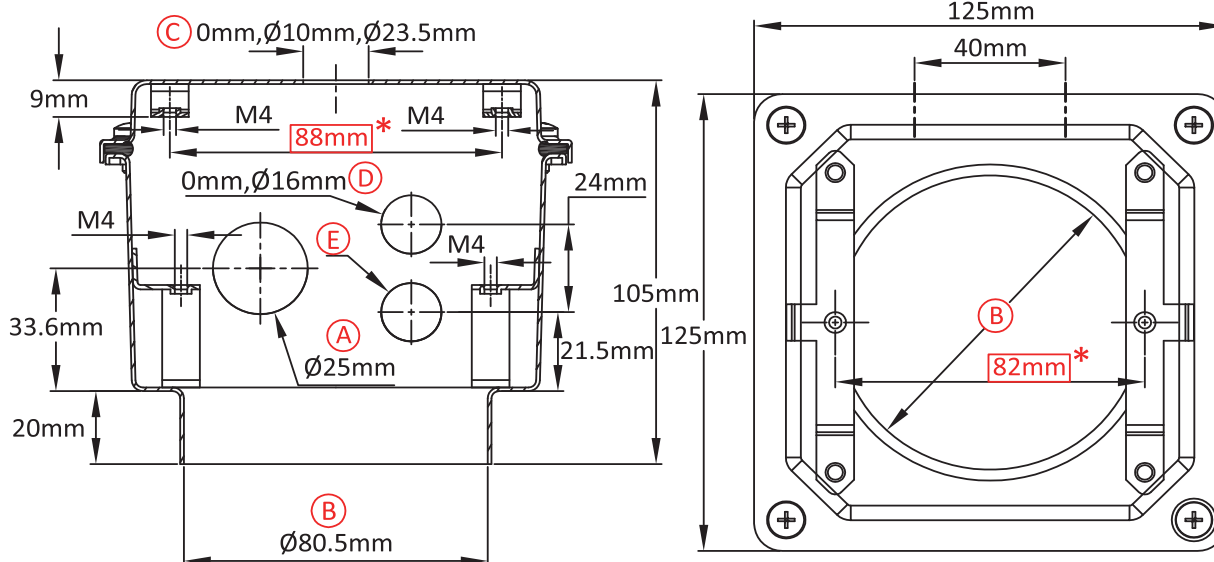

- Temperature sensor
- Immersion heater
- Finned heater
- Thermostat
- Level sensor
- Electronic board



### Main references

(A)(mm)	(B)(mm)	(C)(mm)	(D)(mm)	(E)(mm)	304	316
25	80.5	0	16	16	Y3TB80503S3G1008	Y3TB80503S3G1009
25	80.5	10	16	16	Y3TB805A3S3G1008	Y3TB805A3S3G1009
25	80.5	23.5	16	16	Y3TB805D3S3G1008	Y3TB805D3S3G1009
25	80.5	0	0	16	Y3TB80502C5G1008	Y3TB80502C5G1009
25	80.5	10	0	16	Y3TB805A2C5G1008	Y3TB805A2C5G1009
25	80.5	23.5	0	16	Y3TB805D2C5G1008	Y3TB805D2C5G1009
25	80.5	0	0	0	Y3TB8050125G1008	Y3TB8050125G1009
25	80.5	10	0	0	Y3TB805A125G1008	Y3TB805A125G1009
25	80.5	23.5	0	0	Y3TB805D125G1008	Y3TB805D125G1009

### Links

	Page (.pdf)
	Drawing 2D (.dwg)
	Drawing 3D (.stp)

Cable gland not included in these reference, consult us if you want them.

Red dimensions inside rectangular frames are used for accessories assembly.

# Big enclosure, for immersion heaters or instruments, with flat cover for welding on tubes

Size(mm)	Volume(cm <sup>3</sup> )	Material	Protection grade		Model
<b>125 × 125 × 105</b>	<b>1138</b>	<b>stainless steel</b>	<b>IP69K</b>	<b>IK7</b>	<b>Y3TC</b>

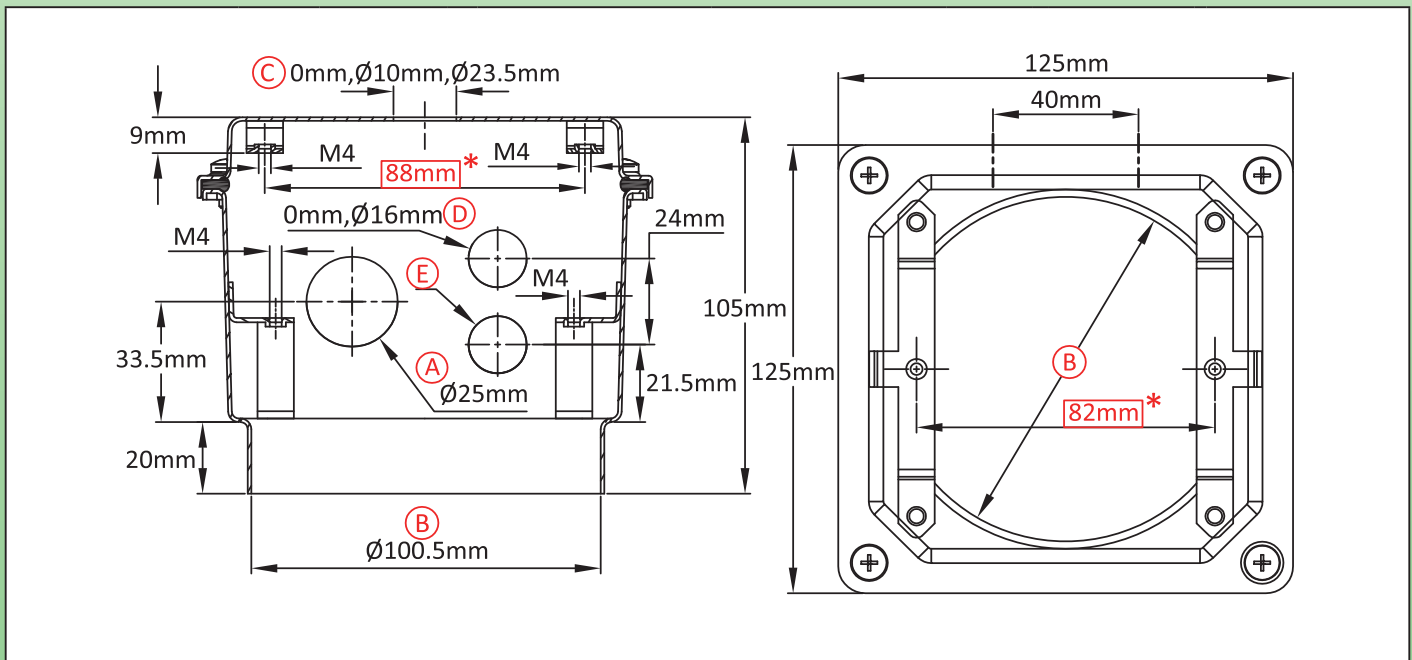
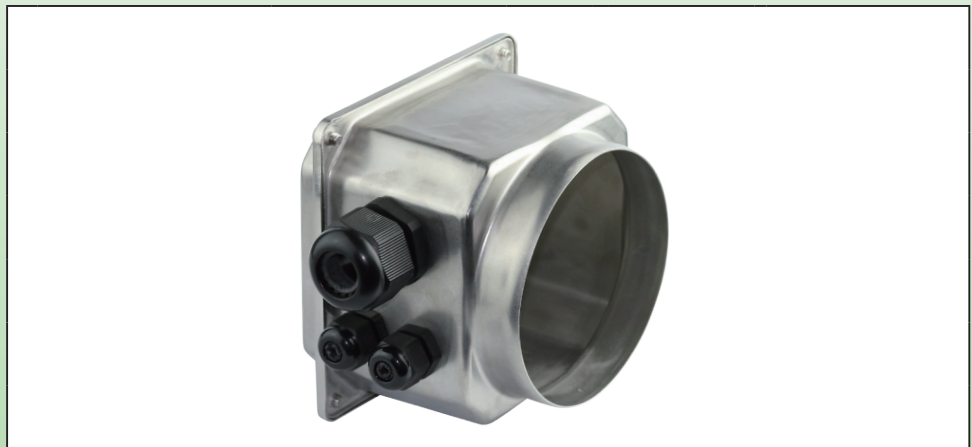

Suitable for
<input type="checkbox"/> Temperature sensor
<input checked="" type="checkbox"/> Immersion heater
<input type="checkbox"/> Finned heater
<input checked="" type="checkbox"/> Thermostat
<input type="checkbox"/> Level sensor
<input checked="" type="checkbox"/> Electronic board



## Main references

A(mm)	B(mm)	C(mm)	D(mm)	E(mm)	304	316
25	100.5	0	16	16	Y3TCA0503S3G1008	Y3TCA0503S3G1009
25	100.5	10	16	16	Y3TCA05A3S3G1008	Y3TCA05A3S3G1009
25	100.5	23.5	16	16	Y3TCA05D3S3G1008	Y3TCA05D3S3G1009
25	100.5	0	0	16	Y3TCA0502C5G1008	Y3TCA0502C5G1009
25	100.5	10	0	16	Y3TCA05A2C5G1008	Y3TCA05A2C5G1009
25	100.5	23.5	0	16	Y3TCA05D2C5G1008	Y3TCA05D2C5G1009
25	100.5	0	0	0	Y3TCA050125G1008	Y3TCA050125G1009
25	100.5	10	0	0	Y3TCA05A125G1008	Y3TCA05A125G1009
25	100.5	23.5	0	0	Y3TCA05D125G1008	Y3TCA05D125G1009

## Links

	Page (.pdf)
	Drawing 2D (.dwg)
	Drawing 3D (.stp)

Cable gland not included in these reference, consult us if you want them.

Red dimensions inside rectangular frames are used for accessories assembly.

Because of permanent improvement of our products, drawings, descriptions, features used on these data sheets are for guidance only and can be modified without prior advice

## Big size enclosure for immersion heater or temperature sensor

Size(mm)	Volume(cm <sup>3</sup> )	Material	Protection grade		Model
<b>125 × 125 × 130</b>	<b>1505</b>	<b>stainless steel</b>	<b>IP69K</b>	<b>IK7</b>	<b>Y3S7</b>

**Suitable for**

- Temperature sensor
- Immersion heater
- Finned heater
- Thermostat
- Level sensor
- Electronic board

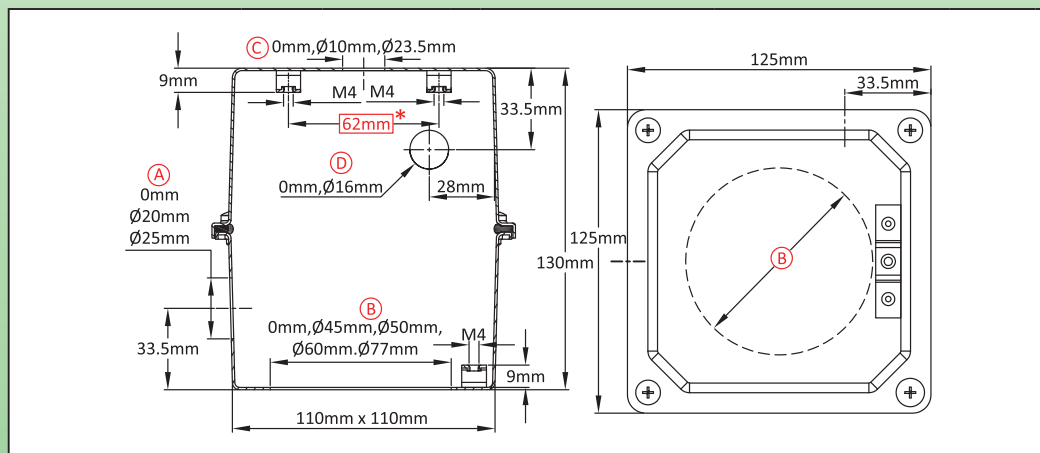

**Links**

Page  
(.pdf)

Drawing 2D  
(.dwg)

Drawing 3D  
(.stp)

### Main references

A		B		C		D		304		316		A		B		C		D		304		316		A		B		C		D		304		316	
0	0	0	0					Y3S70000000G1008		Y3S70000000G1009		20	0	0	0					Y3S70000120G1008		Y3S70000120G1009		25	0	0	0					Y3S70000125G1008		Y3S70000125G1009	
0	0	0	16					Y3S70000116G1008		Y3S70000116G1009		20	0	0	16					Y3S700002C0G1008		Y3S700002C0G1009		25	0	0	16					Y3S700002C5G1008		Y3S700002C5G1009	
0	0	10	0					Y3S7000A000G1008		Y3S7000A000G1009		20	0	10	0					Y3S7000A120G1008		Y3S7000A120G1009		25	0	10	0					Y3S7000A125G1008		Y3S7000A125G1009	
0	0	10	16					Y3S7000A116G1008		Y3S7000A116G1009		20	0	10	16					Y3S7000A2C0G1008		Y3S7000A2C0G1009		25	0	10	16					Y3S7000A2C5G1008		Y3S7000A2C5G1009	
0	0	23.5	0					Y3S7000D000G1008		Y3S7000D000G1009		20	0	23.5	0					Y3S7000D120G1008		Y3S7000D120G1009		25	0	23.5	0					Y3S7000D125G1008		Y3S7000D125G1009	
0	0	23.5	16					Y3S7000D116G1008		Y3S7000D116G1009		20	0	23.5	16					Y3S7000D2C0G1008		Y3S7000D2C0G1009		25	0	23.5	16					Y3S7000D2C5G1008		Y3S7000D2C5G1009	
0	45	0	0					Y3S7450000G1008		Y3S74500000G1009		20	45	0	0					Y3S74500120G1008		Y3S74500120G1009		25	45	0	0					Y3S74500125G1008		Y3S74500125G1009	
0	45	0	16					Y3S74500116G1008		Y3S74500116G1009		20	45	0	16					Y3S745002C0G1008		Y3S745002C0G1009		25	45	0	16					Y3S745002C5G1008		Y3S745002C5G1009	
0	45	10	0					Y3S7450A000G1008		Y3S7450A000G1009		20	45	10	0					Y3S7450A120G1008		Y3S7450A120G1009		25	45	10	0					Y3S7450A125G1008		Y3S7450A125G1009	
0	45	10	16					Y3S7450A116G1008		Y3S7450A116G1009		20	45	10	16					Y3S7450A2C0G1008		Y3S7450A2C0G1009		25	45	10	16					Y3S7450A2C5G1008		Y3S7450A2C5G1009	
0	45	23.5	0					Y3S7450D000G1008		Y3S7450D000G1009		20	45	23.5	0					Y3S7450D120G1008		Y3S7450D120G1009		25	45	23.5	0					Y3S7450D125G1008		Y3S7450D125G1009	
0	45	23.5	16					Y3S7450D116G1008		Y3S7450D116G1009		20	45	23.5	16					Y3S7450D2C0G1008		Y3S7450D2C0G1009		25	45	23.5	16					Y3S7450D2C5G1008		Y3S7450D2C5G1009	
0	50	0	0					Y3S75000000G1008		Y3S75000000G1009		20	50	0	0					Y3S75000120G1008		Y3S75000120G1009		25	50	0	0					Y3S75000125G1008		Y3S75000125G1009	
0	50	0	16					Y3S75000116G1008		Y3S75000116G1009		20	50	0	16					Y3S750002C0G1008		Y3S750002C0G1009		25	50	0	16					Y3S750002C5G1008		Y3S750002C5G1009	
0	50	10	0					Y3S7500A000G1008		Y3S7500A000G1009		20	50	10	0					Y3S7500A120G1008		Y3S7500A120G1009		25	50	10	0					Y3S7500A125G1008		Y3S7500A125G1009	
0	50	10	16					Y3S7500A116G1008		Y3S7500A116G1009		20	50	10	16					Y3S7500A2C0G1008		Y3S7500A2C0G1009		25	50	10	16					Y3S7500A2C5G1008		Y3S7500A2C5G1009	
0	50	23.5	0					Y3S7500D000G1008		Y3S7500D000G1009		20	50	23.5	0					Y3S7500D120G1008		Y3S7500D120G1009		25	50	23.5	0					Y3S7500D125G1008		Y3S7500D125G1009	
0	50	23.5	16					Y3S7500D116G1008		Y3S7500D116G1009		20	50	23.5	16					Y3S7500D2C0G1008		Y3S7500D2C0G1009		25	50	23.5	16					Y3S7500D2C5G1008		Y3S7500D2C5G1009	
0	60	0	0					Y3S76000000G1008		Y3S76000000G1009		20	60	0	0					Y3S76000120G1008		Y3S76000120G1009		25	60	0	0					Y3S76000125G1008		Y3S76000125G1009	
0	60	0	16					Y3S76000116G1008		Y3S76000116G1009		20	60	0	16					Y3S760002C0G1008		Y3S760002C0G1009		25	60	0	16					Y3S760002C5G1008		Y3S760002C5G1009	
0	60	10	0					Y3S7600A000G1008		Y3S7600A000G1009		20	60	10	0					Y3S7600A120G1008		Y3S7600A120G1009		25	60	10	0					Y3S7600A125G1008		Y3S7600A125G1009	
0	60	10	16					Y3S7600A116G1008		Y3S7600A116G1009		20	60	10	16					Y3S7600A2C0G1008		Y3S7600A2C0G1009		25	60	10	16					Y3S7600A2C5G1008		Y3S7600A2C5G1009	
0	60	23.5	0					Y3S7600D000G1008		Y3S7600D000G1009		20	60	23.5	0					Y3S7600D120G1008		Y3S7600D120G1009		25	60	23.5	0					Y3S7600D125G1008		Y3S7600D125G1009	
0	60	23.5	16					Y3S7600D116G1008		Y3S7600D116G1009		20	60	23.5	16					Y3S7600D2C0G1008		Y3S7600D2C0G1009		25	60	23.5	16					Y3S7600D2C5G1008		Y3S7600D2C5G1009	
0	77	0	0					Y3S77700000G1008		Y3S77700000G1009		20	77	0	0					Y3S77700120G1008		Y3S77700120G1009		25	77	0	0					Y3S77700125G1008		Y3S77700125G1009	
0	77	0	16					Y3S77700116G1008		Y3S77700116G1009		20	77	0	16					Y3S777002C0G1008		Y3S777002C0G1009		25	77	0	16					Y3S777002C5G1008		Y3S777002C5G1009	
0	77	10	0					Y3S7770A000G1008		Y3S7770A000G1009		20	77	10	0					Y3S7770A120G1008		Y3S7770A120G1009		25	77	10	0					Y3S7770A125G1008		Y3S7770A125G1009	
0	77	10	16					Y3S7770A116G1008		Y3S7770A116G1009		20	77	10	16					Y3S7770A2C0G1008		Y3S7770A2C0G1009		25	77	10	16					Y3S7770A2C5G1008		Y3S7770A2C5G1009	
0	77	23.5	0					Y3S7770D000G1008		Y3S7770D000G1009		20	77	23.5	0					Y3S7770D120G1008		Y3S7770D120G1009		25	77	23.5	0					Y3S7770D125G1008		Y3S7770D125G1009	
0	77	23.5	16					Y3S7770D116G1008		Y3S7770D116G1009		20	77	23.5	16					Y3S7770D2C0G1008		Y3S7770D2C0G1009		25	77	23.5	16					Y3S7770D2C5G1008		Y3S7770D2C5G1009	

Cable gland not included in these reference, consult us if you want them.

Red dimensions inside rectangular frames are used for accessories assembly.

# Big size enclosure for immersion heater with built-in hexagon

Size(mm)	Volume(cm <sup>3</sup> )	Material	Protection grade		Model
<b>125 × 125 × 138</b>	<b>1525</b>	<b>stainless steel</b>	<b>IP69K</b>	<b>IK7</b>	<b>Y3S8</b>

### Suitable for

- Temperature sensor
- Immersion heater
- Finned heater
- Thermostat
- Level sensor
- Electronic board

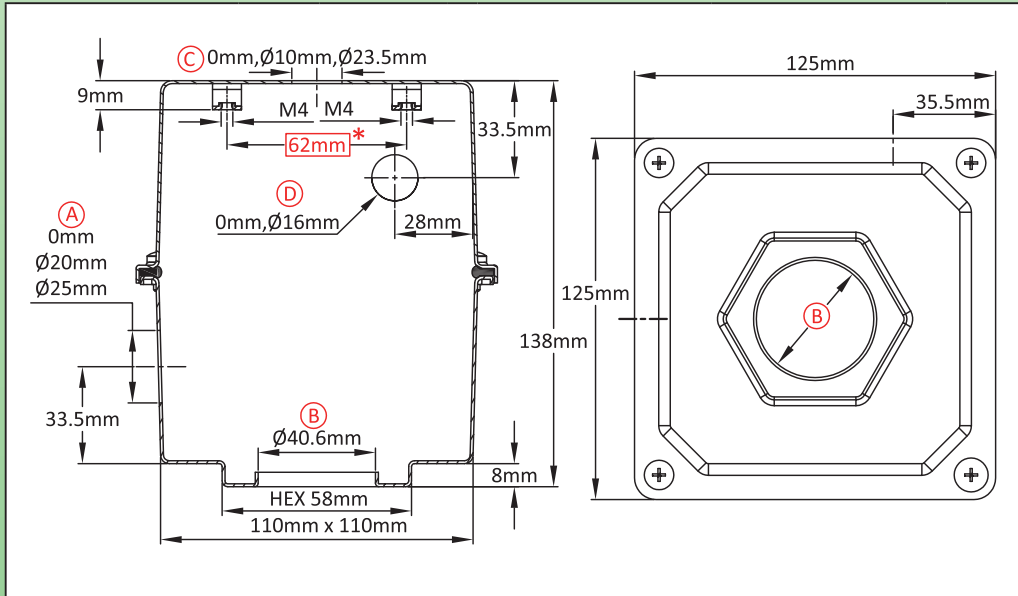
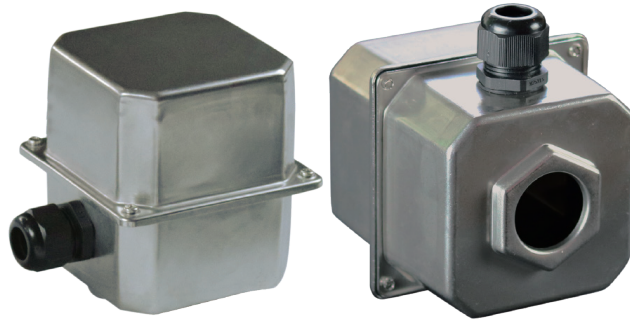

### Links



Page  
(.pdf)



Drawing 2D  
(.dwg)



Drawing 3D  
(.stp)

### Main references

(A) (mm)	(B) (mm)	(C) (mm)	(D) (mm)	304	316	(A) (mm)	(B) (mm)	(C) (mm)	(D) (mm)	304	316
0	40.6	0	0	Y3S84060000G1008	Y3S84060000G1009	20	40.6	10	16	Y3S8406A2C0G1008	Y3S8406A2C0G1009
0	40.6	0	16	Y3S84060116G1008	Y3S84060116G1009	20	40.6	23.5	0	Y3S8406D120G1008	Y3S8406D120G1009
0	40.6	10	0	Y3S8406A000G1008	Y3S8406A000G1009	20	40.6	23.5	16	Y3S8406D2C0G1008	Y3S8406D2C0G1009
0	40.6	10	16	Y3S8406A116G1008	Y3S8406A116G1009	25	40.6	0	0	Y3S84060125G1008	Y3S84060125G1009
0	40.6	23.5	0	Y3S8406D000G1008	Y3S8406D000G1009	25	40.6	0	16	Y3S840602C5G1008	Y3S840602C5G1009
0	40.6	23.5	16	Y3S8406D116G1008	Y3S8406D116G1009	25	40.6	10	0	Y3S8406A125G1008	Y3S8406A125G1009
20	40.6	0	0	Y3S84060120G1008	Y3S84060120G1009	25	40.6	10	16	Y3S8406A2C5G1008	Y3S8406A2C5G1009
20	40.6	0	16	Y3S840602C0G1008	Y3S840602C0G1009	25	40.6	23.5	0	Y3S8406D125G1008	Y3S8406D125G1009
20	40.6	10	0	Y3S8406A120G1008	Y3S8406A120G1009	25	40.6	23.5	16	Y3S8406D2C5G1008	Y3S8406D2C5G1009

Cable gland not included in these reference, consult us if you want them.

Red dimensions inside rectangular frames are used for accessories assembly.

Because of permanent improvement of our products, drawings, descriptions, features used on these data sheets are for guidance only and can be modified without prior advice

# Big size enclosure with built in hexagon for large size immersion heaters

Size(mm)	Volume(cm <sup>3</sup> )	Material	Protection grade		Model
125 × 125 × 138	1551	stainless steel	IP69K	IK7	<b>Y3S9</b>

### Suitable for

- Temperature sensor
- Immersion heater
- Finned heater
- Thermostat
- Level sensor
- Electronic board

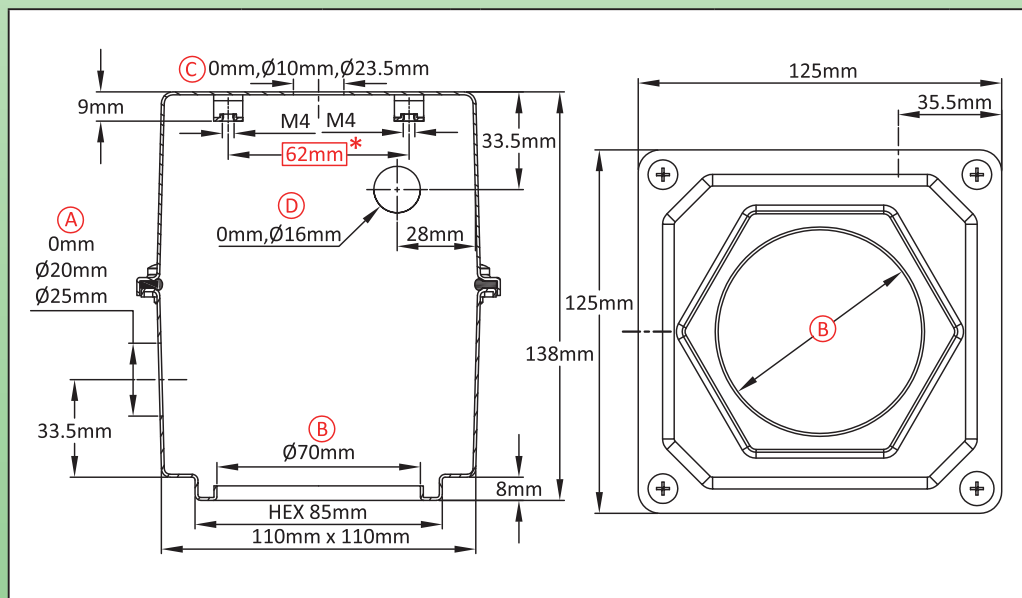

### Links



Page  
(.pdf)



Drawing 2D  
(.dwg)



Drawing 3D  
(.stp)

### Main references

(A) (mm)	(B) (mm)	(C) (mm)	(D) (mm)	304	316	(A) (mm)	(B) (mm)	(C) (mm)	(D) (mm)	304	316
0	70	0	0	Y3S97000000G1008	Y3S97000000G1009	20	70	10	16	Y3S9700A2C0G1008	Y3S9700A2C0G1009
0	70	0	16	Y3S97000116G1008	Y3S97000116G1009	20	70	23.5	0	Y3S9700D120G1008	Y3S9700D120G1009
0	70	10	0	Y3S9700A000G1008	Y3S9700A000G1009	20	70	23.5	16	Y3S9700D2C0G1008	Y3S9700D2C0G1009
0	70	10	16	Y3S9700A116G1008	Y3S9700A116G1009	25	70	0	0	Y3S97000125G1008	Y3S97000125G1009
0	70	23.5	0	Y3S9700D000G1008	Y3S9700D000G1009	25	70	0	16	Y3S970002C5G1008	Y3S970002C5G1009
0	70	23.5	16	Y3S9700D116G1008	Y3S9700D116G1009	25	70	10	0	Y3S9700A125G1008	Y3S9700A125G1009
20	70	0	0	Y3S97000120G1008	Y3S97000120G1009	25	70	10	16	Y3S9700A2C5G1008	Y3S9700A2C5G1009
20	70	0	16	Y3S970002C0G1008	Y3S970002C0G1009	25	70	23.5	0	Y3S9700D125G1008	Y3S9700D125G1009
20	70	10	0	Y3S9700A120G1008	Y3S9700A120G1009	25	70	23.5	16	Y3S9700D2C5G1008	Y3S9700D2C5G1009

Cable gland not included in these reference, consult us if you want them.

Red dimensions inside rectangular frames are used for accessories assembly.



# Big size immersion heater or controls enclosure, for direct welding on pipes

Size(mm)	Volume(cm <sup>3</sup> )	Material	Protection grade		Model
125 × 125 × 135	1668	stainless steel	IP69K	IK7	<b>Y3T8</b>

### Suitable for

- Temperature sensor
- Immersion heater
- Finned heater
- Thermostat
- Level sensor
- Electronic board

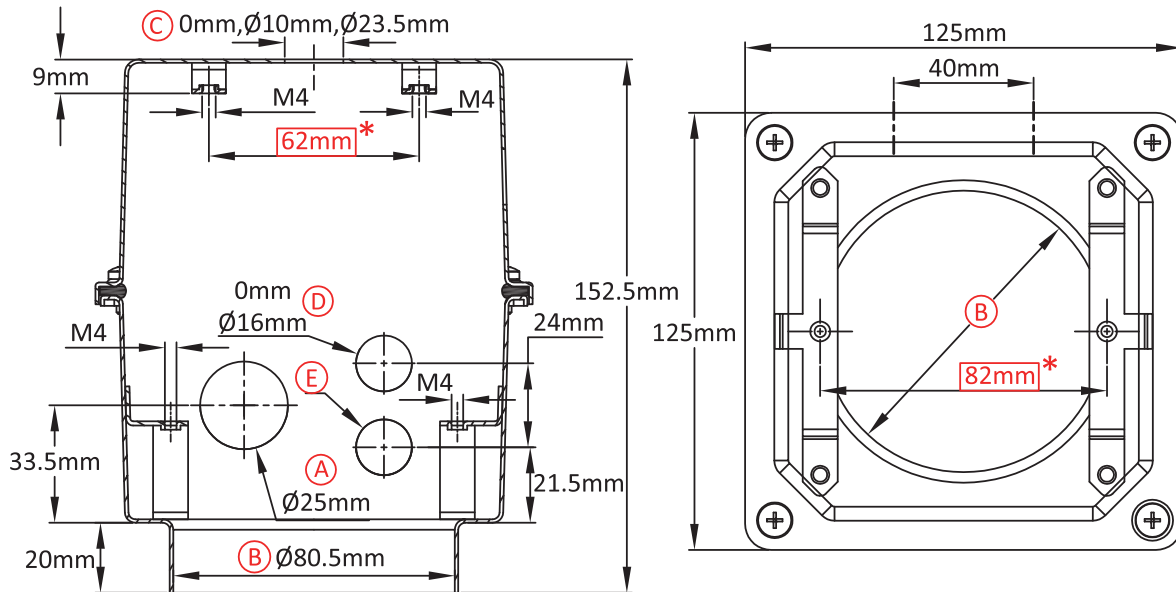

### Main references

A(mm)	B(mm)	C(mm)	D(mm)	E(mm)	304	316
25	80.5	0	16	16	Y3T880503S3G1008	Y3T880503S3G1009
25	80.5	0	0	16	Y3T880502C5G1008	Y3T880502C5G1009
25	80.5	0	0	0	Y3T88050125G1008	Y3T88050125G1009
25	80.5	10	16	16	Y3T8805A3S3G1008	Y3T8805A3S3G1009
25	80.5	10	0	16	Y3T8805A2C5G1008	Y3T8805A2C5G1009
25	80.5	10	0	0	Y3T8805A125G1008	Y3T8805A125G1009
25	80.5	23.5	16	16	Y3T8805D3S3G1008	Y3T8805D3S3G1009
25	80.5	23.5	0	16	Y3T8805D2C5G1008	Y3T8805D2C5G1009
25	80.5	23.5	0	0	Y3T8805D125G1008	Y3T8805D125G1009

### Links

	Page (.pdf)
	Drawing 2D (.dwg)
	Drawing 3D (.stp)

Cable gland not included in these reference, consult us if you want them.

Red dimensions inside rectangular frames are used for accessories assembly.

Because of permanent improvement of our products, drawings, descriptions, features used on these data sheets are for guidance only and can be modified without prior advice

# Big size immersion heater or controls enclosure, for direct welding on pipes

Size(mm)	Volume(cm <sup>3</sup> )	Material	Protection grade		Model
125 × 125 × 135	1668	stainless steel	IP69K	IK7	<b>Y3TA</b>

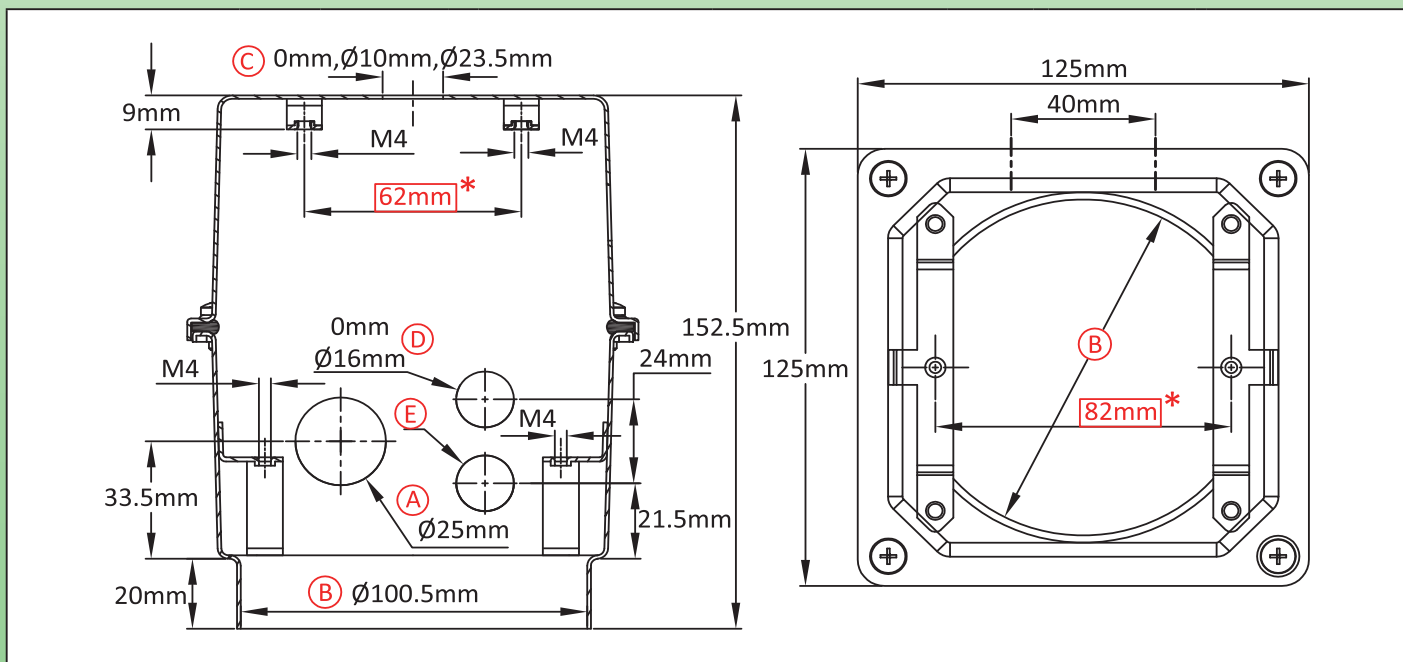

Suitable for
<input type="checkbox"/> Temperature sensor
<input checked="" type="checkbox"/> Immersion heater
<input type="checkbox"/> Finned heater
<input checked="" type="checkbox"/> Thermostat
<input type="checkbox"/> Level sensor
<input checked="" type="checkbox"/> Electronic board



## Main references

Ⓐ(mm)	Ⓑ(mm)	Ⓒ(mm)	Ⓓ(mm)	Ⓔ(mm)	304	316
25	100.5	0	16	16	Y3TAA0503S3G1008	Y3TAA0503S3G1009
25	100.5	10	16	16	Y3TAA05A3S3G1008	Y3TAA05A3S3G1009
25	100.5	23.5	16	16	Y3TAA05D3S3G1008	Y3TAA05D3S3G1009
25	100.5	0	0	16	Y3TAA0502C5G1008	Y3TAA0502C5G1009
25	100.5	10	0	16	Y3TAA05A2C5G1008	Y3TAA05A2C5G1009
25	100.5	23.5	0	16	Y3TAA05D2C5G1008	Y3TAA05D2C5G1009
25	100.5	0	0	0	Y3TAA050125G1008	Y3TAA050125G1009
25	100.5	10	0	0	Y3TAA05A125G1008	Y3TAA05A125G1009
25	100.5	23.5	0	0	Y3TAA05D125G1008	Y3TAA05D125G1009

## Links

	Page (.pdf)
	Drawing 2D (.dwg)
	Drawing 3D (.stp)

Cable gland not included in these reference, consult us if you want them.

Red dimensions inside rectangular frames are used for accessories assembly.



# Plastic enclosures

**The references given in these documents are the most common. The dotted areas in the plans indicate the options.**

Unless otherwise specified, these enclosures are in fiberglass reinforced PA 6.6 and transparent covers are in polycarbonate.

**Red dimensions inside rectangular frames on drawings are used for accessories assembly.**

For more information consult our technical service.



# Sub-miniature enclosure for temperature sensor, level sensor, electronic printed circuit or cartridge heater, Removable wall mounting bracket

Size(mm)	Volume(cm <sup>3</sup> )	Material	Protection grade		Model
61 x 33 x 30	52	PA66	IPX4	IK8	<b>Y3A1</b>

## Suitable for

- Temperature sensor
- Immersion heater
- Finned heater
- Thermostat
- Level sensor
- Electronic board

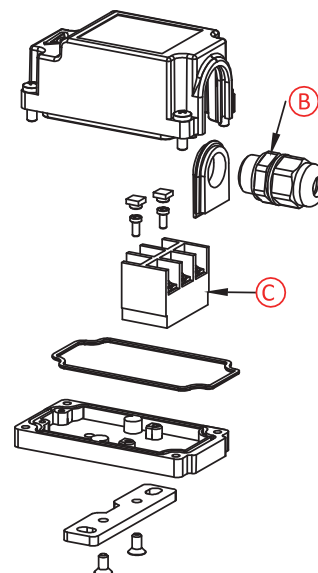
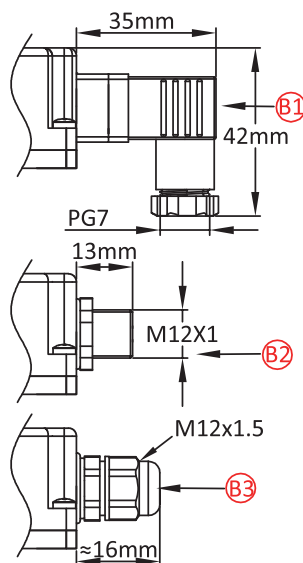
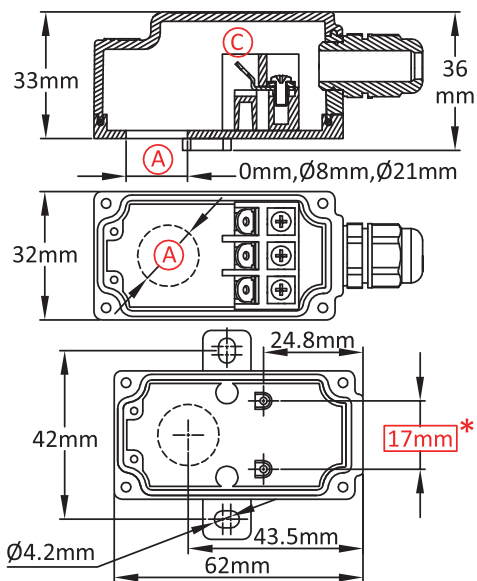

## Main references

(A) (mm)	(B1)	(B2)	(B3)	With connection block (C)	Without connection block (C)
0	✓	×	×	Y3A100001E1F100T	Y3A100001E1000T
0	×	✓	×	Y3A100001E3F100T	Y3A100001E3000T
0	×	×	✓	Y3A100001E2F100T	Y3A100001E2000T
8	✓	×	×	Y3A108001E1F100T	Y3A108001E1000T
8	×	✓	×	Y3A108001E3F100T	Y3A108001E3000T
8	×	×	✓	Y3A108001E2F100T	Y3A108001E2000T
21	✓	×	×	Y3A121001E1F100T	Y3A121001E1000T
21	×	✓	×	Y3A121001E3F100T	Y3A121001E3000T
21	×	×	✓	Y3A121001E2F100T	Y3A121001E2000T

## Links



Page  
(.pdf)



Drawing 2D  
(.dwg)



Drawing 3D  
(.stp)

Others drilling diameters on request.

Red dimensions inside rectangular frames on drawings are used for accessories assembly.

# Sub-miniature enclosure for temperature sensor, level sensor, electronic printed circuit or cartridge heater, Removable wall mounting bracket

Size(mm)	Volume(cm <sup>3</sup> )	Material	Protection grade		Model
70 x 33 x 33	72	PA66	IPX4	IK8	<b>Y3A2</b>

Suitable for
<input checked="" type="checkbox"/> Temperature sensor
<input type="checkbox"/> Immersion heater
<input type="checkbox"/> Finned heater
<input type="checkbox"/> Thermostat
<input checked="" type="checkbox"/> Level sensor
<input checked="" type="checkbox"/> Electronic board

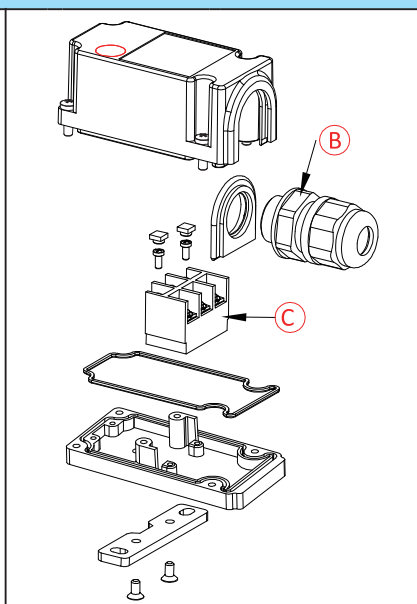
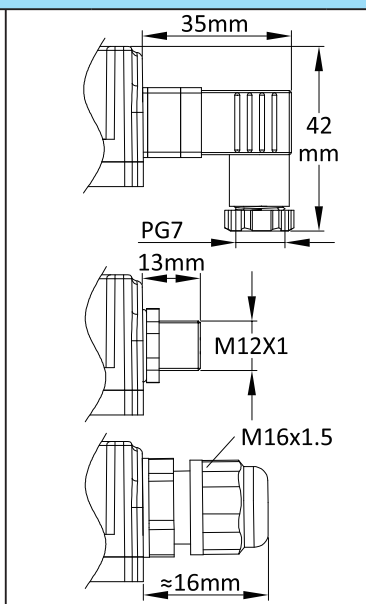
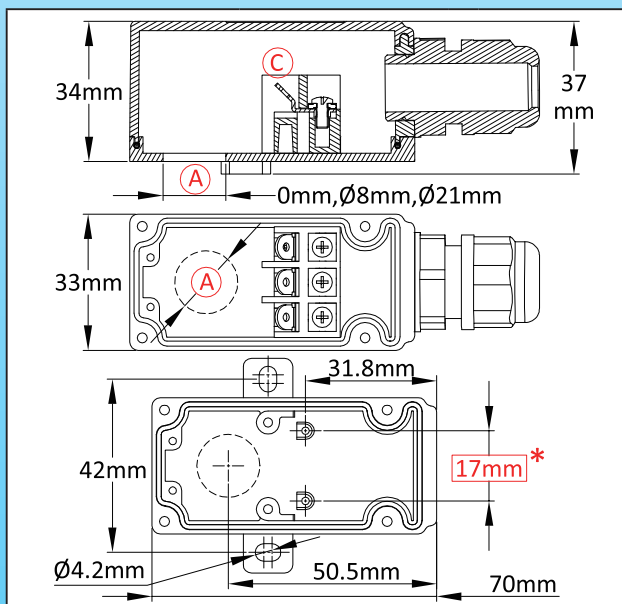
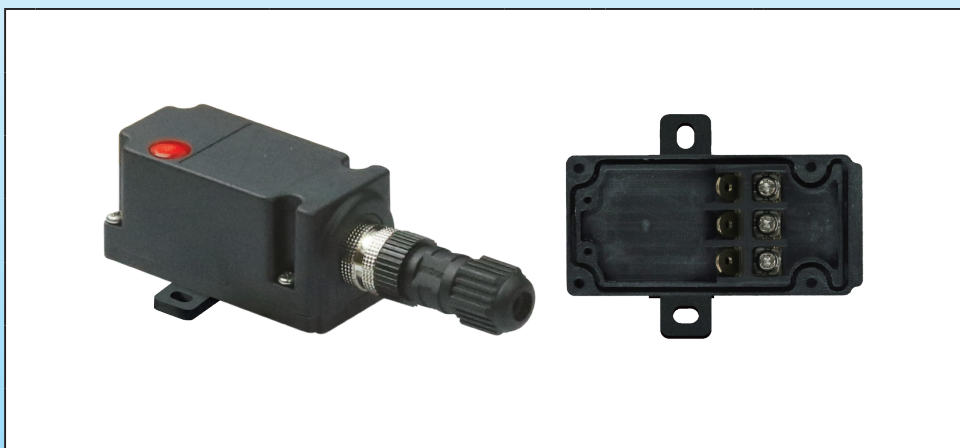

## Main references

(A) (mm)	(B1)	(B2)	(B3)	With connection block (C)	Without connection block (C)
0	✓	×	×	Y3A200001E1F100T	Y3A200001E10000T
0	×	✓	×	Y3A200001E3F100T	Y3A200001E30000T
0	×	×	✓	Y3A200001E6F100T	Y3A200001E60000T
8	✓	×	×	Y3A208001E1F100T	Y3A208001E10000T
8	×	✓	×	Y3A208001E3F100T	Y3A208001E30000T
8	×	×	✓	Y3A208001E6F100T	Y3A208001E60000T
21	✓	×	×	Y3A221001E1F100T	Y3A221001E10000T
21	×	✓	×	Y3A221001E3F100T	Y3A221001E30000T
21	×	×	✓	Y3A221001E6F100T	Y3A221001E60000T

## Links



Page  
(.pdf)



Drawing 2D  
(.dwg)



Drawing 3D  
(.stp)

Others drilling diameters on request.

Red dimensions inside rectangular frames on drawings are used for accessories assembly.

# Miniature enclosure for temperature sensor, level sensor, electronic printed circuit or cartridge heater

Size(mm)	Volume(cm <sup>3</sup> )	Material	Protection grade		Model
100 x 56 x 37	208	PA66	IP69K	IK10	<b>Y3A3</b>

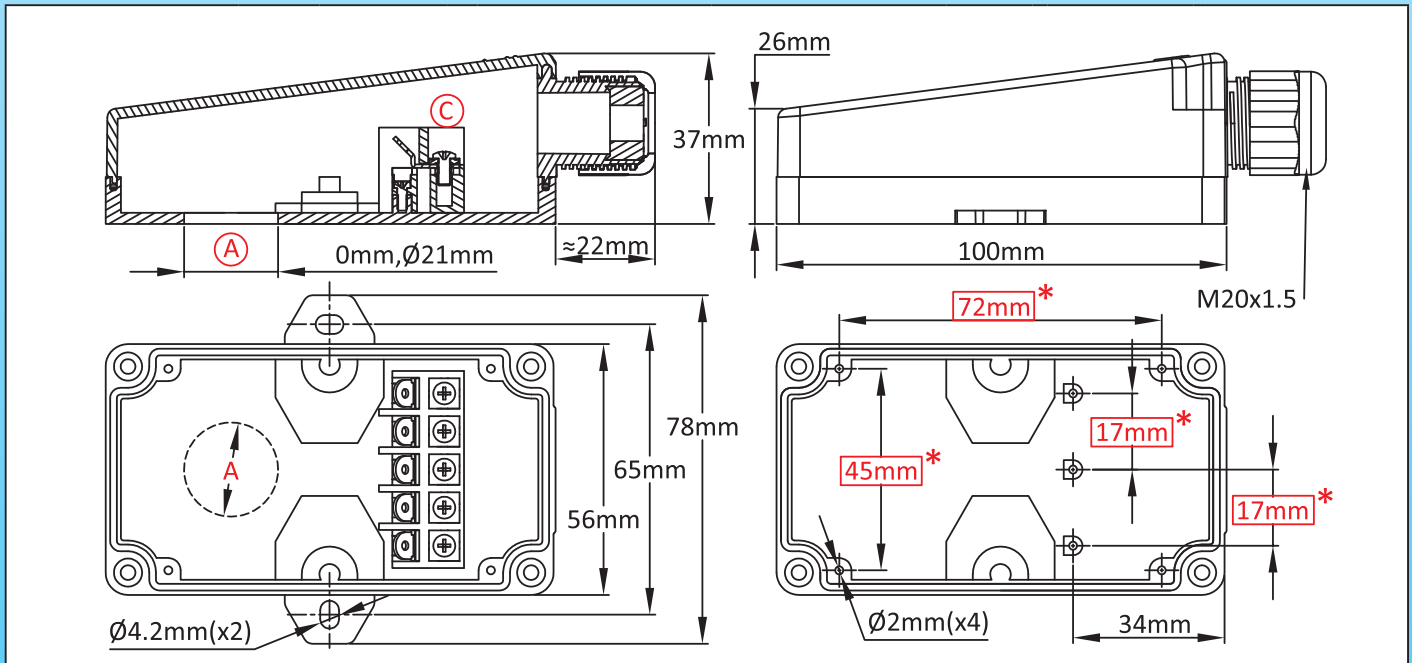
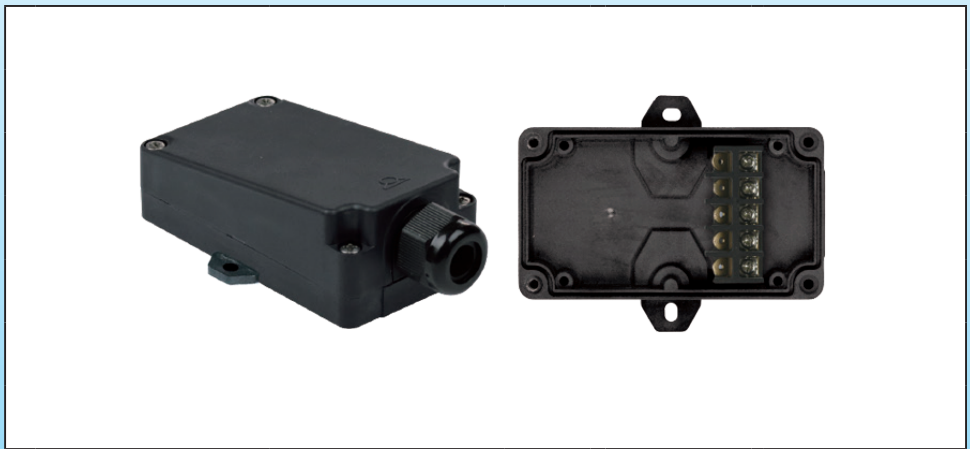

Suitable for
<input checked="" type="checkbox"/> Temperature sensor
<input type="checkbox"/> Immersion heater
<input type="checkbox"/> Finned heater
<input type="checkbox"/> Thermostat
<input checked="" type="checkbox"/> Level sensor
<input checked="" type="checkbox"/> Electronic board



## Main references

A (mm)	With connection block C	Without connection block C
0	Y3A300001E0F100T	Y3A300001E00000T
8	Y3A308001E0F100T	Y3A308001E00000T
21	Y3A321001E0F100T	Y3A321001E00000T

## Links

	Page (.pdf)
	Drawing 2D (.dwg)
	Drawing 3D (.stp)

Because of permanent improvement of our products, drawings, descriptions, features used on these data sheets are for guidance only and can be modified without prior advice

Others drilling diameters on request.

Red dimensions inside rectangular frames on drawings are used for accessories assembly.

# Miniature enclosure for temperature sensor, level sensor, electronic printed circuit or cartridge heater

Size(mm)	Volume(cm <sup>3</sup> )	Material	Protection grade		Model
100 x 56 x 48	216	PA66	IP69K	IK10	<b>Y3A4</b>

## Suitable for

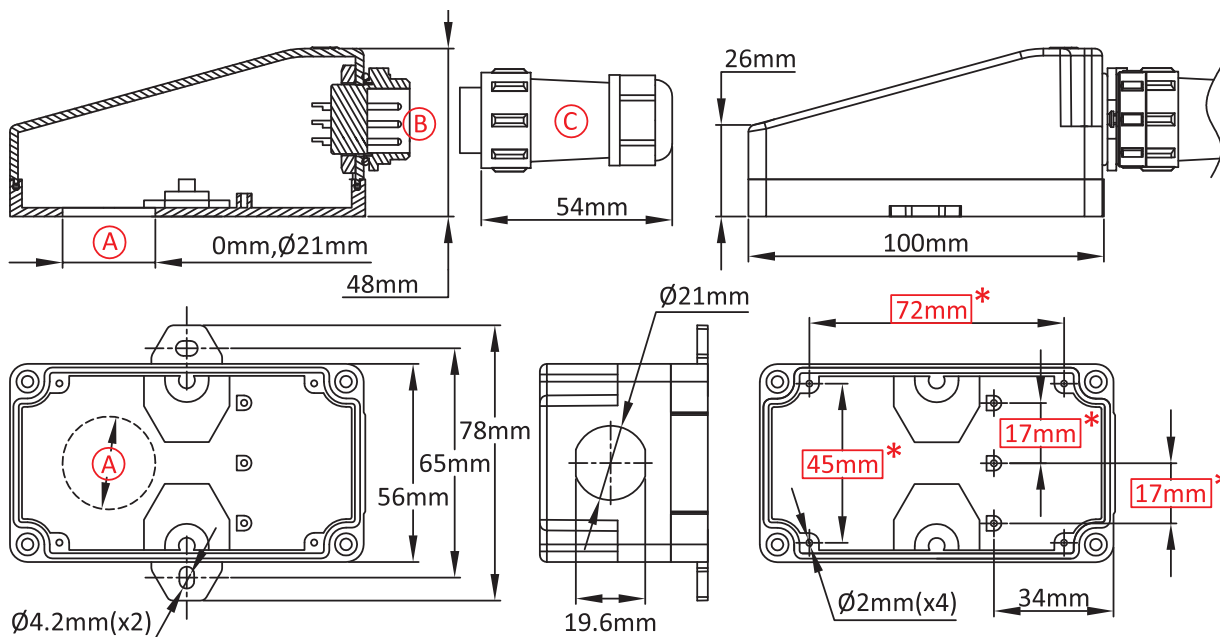

- Temperature sensor
- Immersion heater
- Finned heater
- Thermostat
- Level sensor
- Electronic board



## Main references

A (mm)	B	C	Without connection block
0	x	x	Y3A400001210000T
0	v	x	Y3A400001E80000T
0	v	v	Y3A400001E90000T
8	x	x	Y3A408001210000T
8	v	x	Y3A408001E80000T
8	v	v	Y3A408001E90000T
21	x	x	Y3A421001210000T
21	v	x	Y3A421001E80000T
21	v	v	Y3A421001E90000T

## Links

	Page (.pdf)
	Drawing 2D (.dwg)
	Drawing 3D (.stp)

Others drilling diameters on request.

Red dimensions inside rectangular frames on drawings are used for accessories assembly.



# Miniature enclosure for temperature sensor, level sensor, electronic printed circuit or cartridge heater

Size(mm)	Volume(cm <sup>3</sup> )	Material	Protection grade		Model
48 x 48 x 41	93	PA66	IPX5	IK8	<b>Y301</b>

Suitable for
<input type="checkbox"/> Temperature sensor
<input checked="" type="checkbox"/> Immersion heater
<input type="checkbox"/> Finned heater
<input type="checkbox"/> Thermostat
<input type="checkbox"/> Level sensor
<input type="checkbox"/> Electronic board

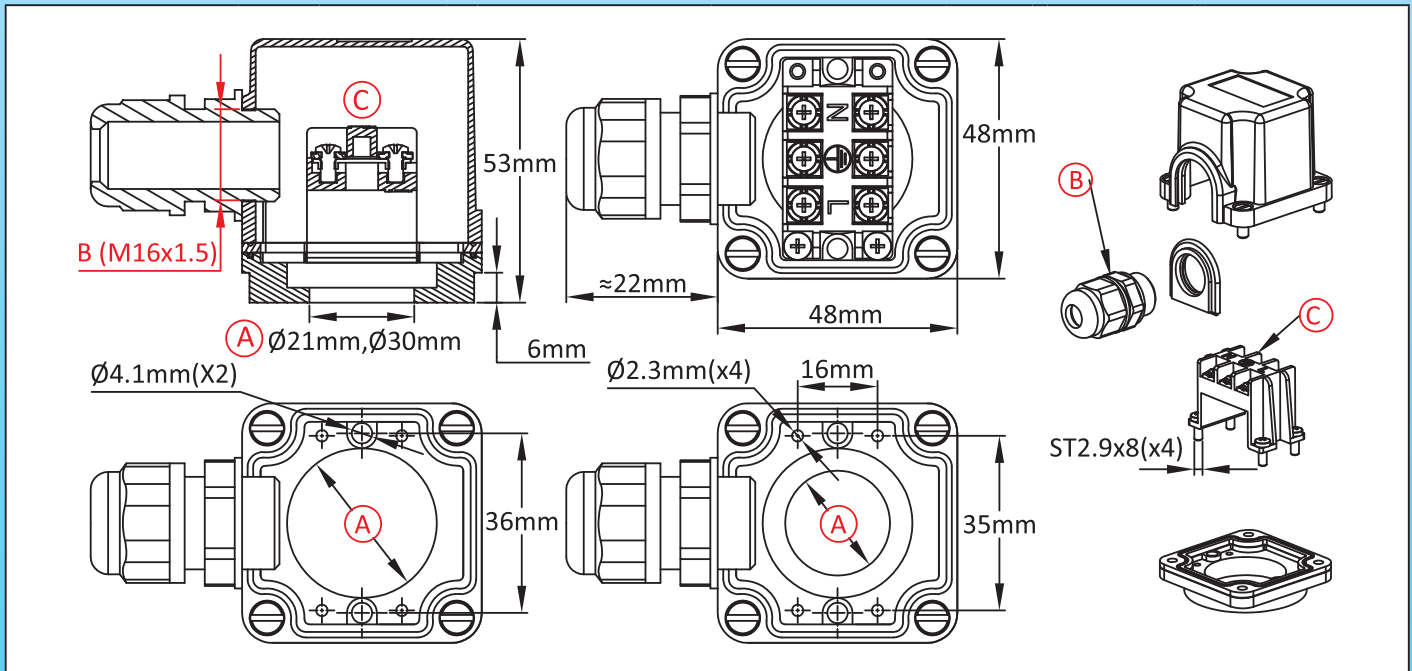

## Main references

(A)(mm)	With connection block (C)	Without connection block (C)
21	Y30121001E6H100T	Y30121001E60000T
30	Y30130001E6H100T	Y30130001E60000T

## Links

	Page (.pdf)
	Drawing 2D (.dwg)
	Drawing 3D (.stp)

Cable gland not included in these reference, consult us if you want them.  
 Red dimensions inside rectangular frames on drawings are used for accessories assembly.

Because of permanent improvement of our products, drawings, descriptions, features used on these data sheets are for guidance only and can be modified without prior advice

## Simplified immersion heater enclosure for fittings with M4 central screw

Size(mm)	Volume(cm <sup>3</sup> )	Material	Protection grade		Model
Dia. 54 x 66	160	PA66	IP69K	IK8	<b>Y302</b>

### Suitable for

- Temperature sensor
- Immersion heater
- Finned heater
- Thermostat
- Level sensor
- Electronic board

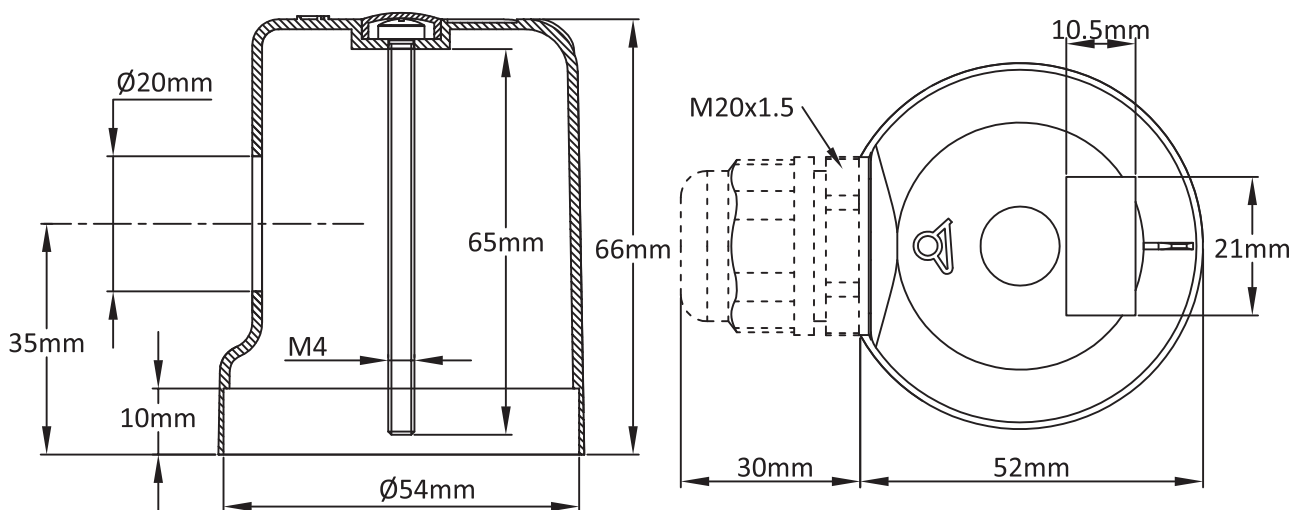

### Main reference

Y30200011200000T

### Links



Page  
(.pdf)



Drawing 2D  
(.dwg)



Drawing 3D  
(.stp)

Presse-étoupe non inclus dans la référence ci-dessus. Avec presse-étoupe fourni et monté, remplacer xx par yy dans la référence.  
Red dimensions inside rectangular frames on drawings are used for accessories assembly.

# Immersion heater enclosure for standard fittings with three M4 mounting screws at 120°

Size(mm)	Volume(cm <sup>3</sup> )	Material	Protection grade		Model
<b>Dia. 54 x 74</b>	<b>180</b>	<b>PA66</b>	<b>IP69K</b>	<b>IK8</b>	<b>Y3C1</b>

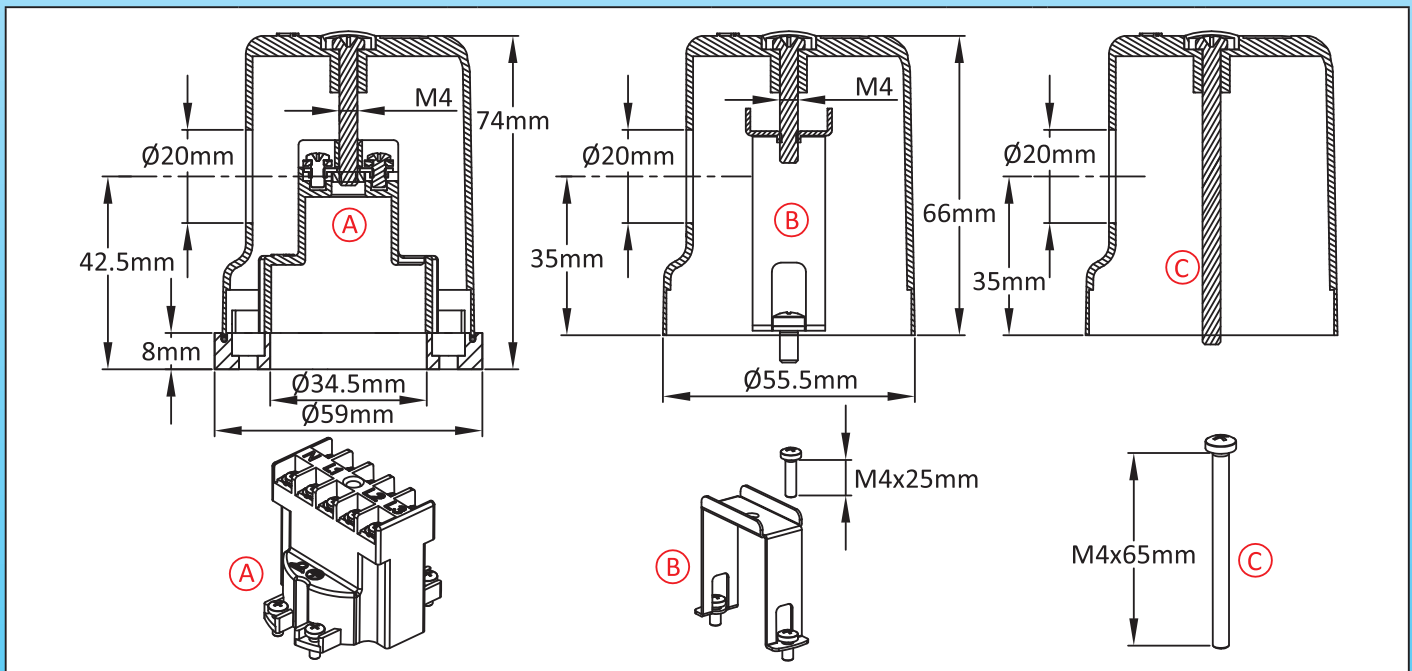

Suitable for
<input type="checkbox"/> Temperature sensor
<input type="checkbox"/> Immersion heater
<input checked="" type="checkbox"/> Finned heater
<input type="checkbox"/> Thermostat
<input type="checkbox"/> Level sensor
<input type="checkbox"/> Electronic board



### Main references

Ⓐ	Ⓑ	Ⓒ	References
√	×	×	Y3C10001120H200T
×	√	×	Y3C10001120E100T
×	×	√	Y3C100011200100T

### Links

	Page (.pdf)
	Drawing 2D (.dwg)
	Drawing 3D (.stp)

Cable gland not included in these reference, consult us if you want them.  
 Red dimensions inside rectangular frames on drawings are used for accessories assembly.

Because of permanent improvement of our products, drawings, descriptions, features used on these data sheets are for guidance only and can be modified without prior advice

# Miniature Enclosure for 2" fittings

Size(mm)	Volume(cm <sup>3</sup> )	Material	Protection grade		Model
Dia. 65 x 66	200	PA66	IP69K	IK8	<b>Y3C2</b>

Suitable for
<input type="checkbox"/> Temperature sensor
<input checked="" type="checkbox"/> Immersion heater
<input type="checkbox"/> Finned heater
<input type="checkbox"/> Thermostat
<input type="checkbox"/> Level sensor
<input type="checkbox"/> Electronic board

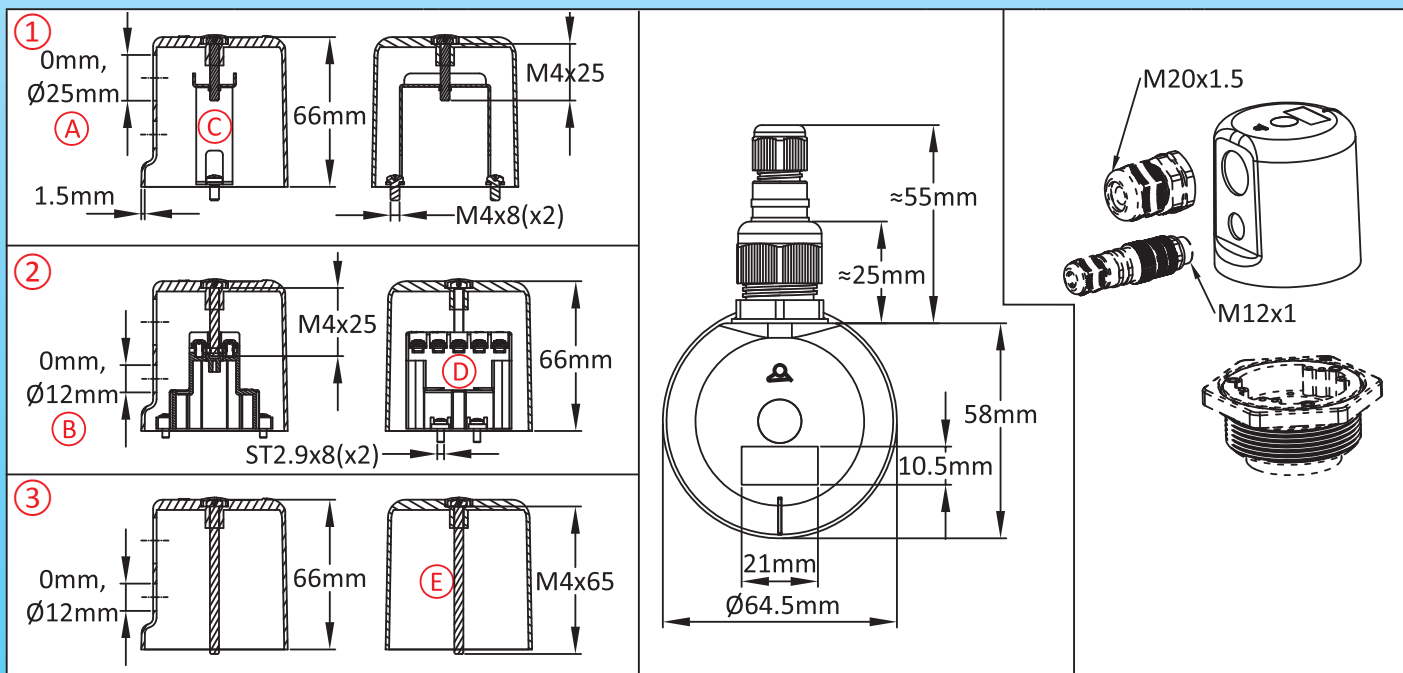
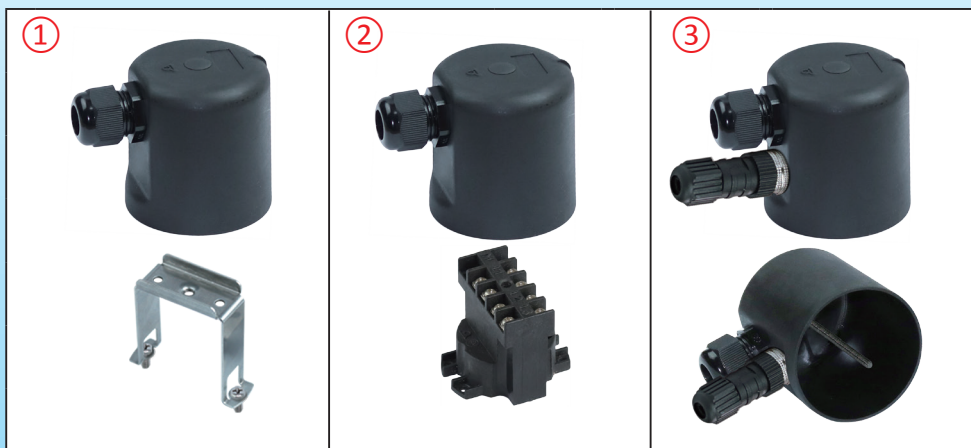

## Main references

(A)(mm)	(B)(mm)	(C) (With saddle)	(D)(With connection block)	(E) (With center screw)	References
0	0	√	×	×	Y3C20001000E100T
0	0	×	√	×	Y3C20001000H200T
0	0	×	×	√	Y3C200010000100T
0	12	√	×	×	Y3C20001112E100T
0	12	×	√	×	Y3C20001112H200T
0	12	×	×	√	Y3C20001120100T
25	0	√	×	×	Y3C20001125E100T
25	0	×	√	×	Y3C20001125H200T
25	0	×	×	√	Y3C200011250100T
25	12	√	×	×	Y3C200012A0E100T
25	12	×	√	×	Y3C200012A0H200T
25	12	×	×	√	Y3C200012A00100T

## Links

	Page (.pdf)
	Drawing 2D (.dwg)
	Drawing 3D (.stp)

Cable gland not included in these reference, consult us if you want them.

Red dimensions inside rectangular frames on drawings are used for accessories assembly.

## Simplified round enclosure for 2"1/2 and M77x2 fittings

Size(mm)	Volume(cm <sup>3</sup> )	Material	Protection grade		Model
Dia. 86 × 75	416	PA66	IP69K	IK9	<b>Y3C3</b>

### Suitable for

- Temperature sensor
- Immersion heater
- Finned heater
- Thermostat
- Level sensor
- Electronic board

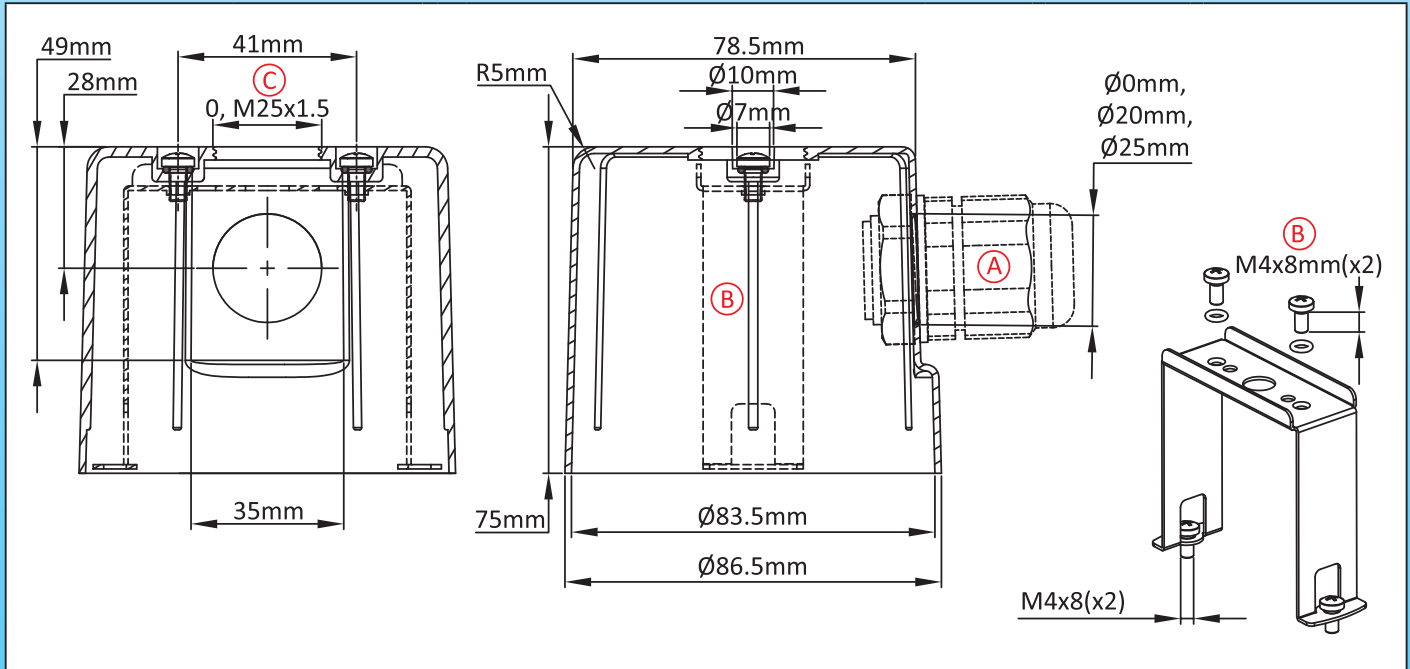

### Main references

Ⓐ (mm)	Ⓑ (mm)	Ⓒ (Avec étrier)	References
0	√	0	Y3C30000000E200T
0	√	M25x1.5	Y3C3000F000E200T
20	√	0	Y3C30000120E200T
20	√	M25x1.5	Y3C3000F120E200T
25	√	0	Y3C30000125E200T
25	√	M25x1.5	Y3C3000F125E200T

### Links

	Page (.pdf)
	Drawing 2D (.dwg)
	Drawing 3D (.stp)

Cable gland not included in these reference, consult us if you want them.

Red dimensions inside rectangular frames on drawings are used for accessories assembly.

## Temperature sensor, thermostat or level sensor enclosure

Size(mm)	Volume(cm <sup>3</sup> )	Material	Protection grade		Model
105 x 88 x 58.5	550	PA66	IP69K	IK10	<b>Y3B1</b>

### Suitable for

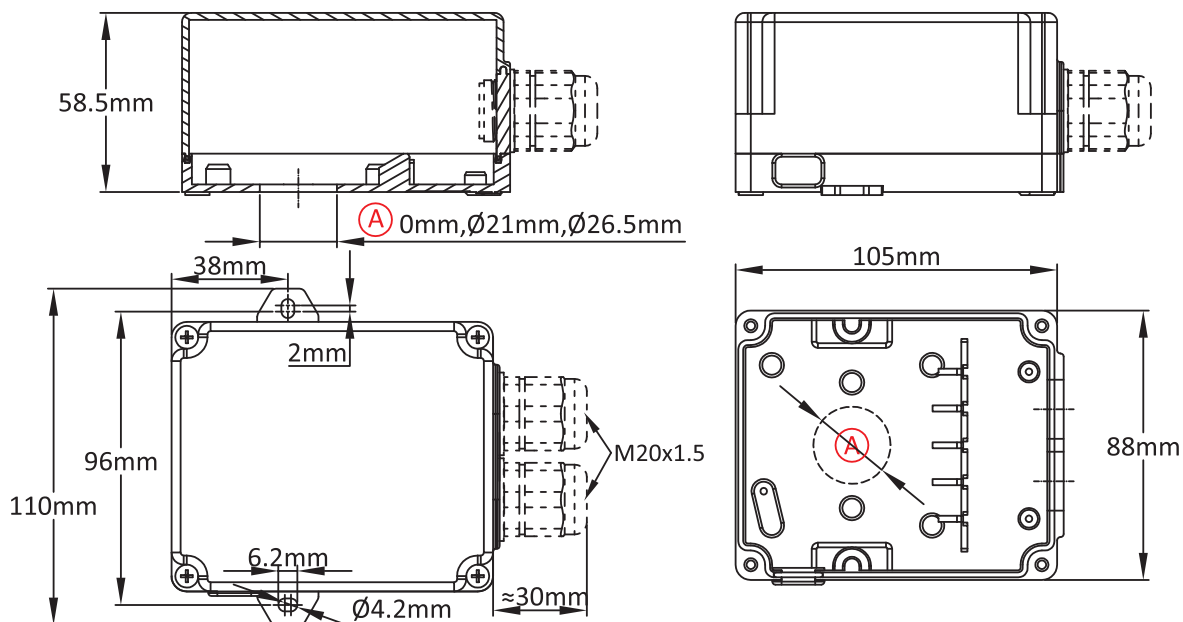
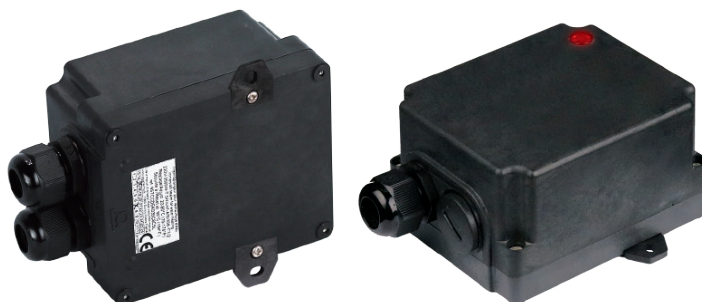

- Temperature sensor
- Immersion heater
- Finned heater
- Thermostat
- Level sensor
- Electronic board



### Main references

Ⓐ(mm)	References
0	Y3B1000022C0000T
21	Y3B1210022C0000T
26.5	Y3B1265022C0000T

### Links

	Page (.pdf)
	Drawing 2D (.dwg)
	Drawing 3D (.stp)

Cable gland not included in these reference, consult us if you want them.

Red dimensions inside rectangular frames on drawings are used for accessories assembly.

# Immersion heater housing for commercial water heater tanks

Size(mm)	Volume(cm <sup>3</sup> )	Material	Protection grade		Model
105 X 88 x 84.5	633	PA66	IP69K	IK10	<b>Y3B2</b>

## Suitable for

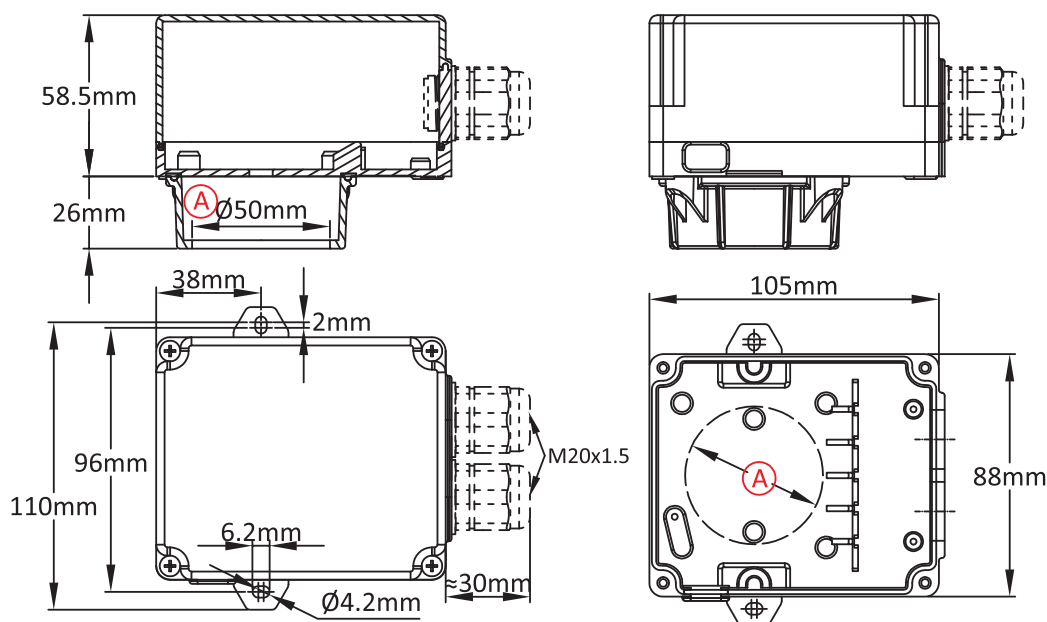

- Temperature sensor
- Immersion heater
- Finned heater
- Thermostat
- Level sensor
- Electronic board



## Main references

<span style="border: 1px solid red; border-radius: 50%; padding: 2px;">A</span> (mm)	References
50	Y3B2500022C0000T

## Links

	Page (.pdf)
	Drawing 2D (.dwg)
	Drawing 3D (.stp)

Cable gland not included in these reference, consult us if you want them.

Red dimensions inside rectangular frames on drawings are used for accessories assembly.

# Round enclosure for immersion heater or temperature sensor

Size(mm)	Volume(cm <sup>3</sup> )	Material	Protection grade		Model
<b>Dia. 100 x 100</b>	<b>700</b>	<b>PA66</b>	<b>IP69K</b>	<b>IK10</b>	<b>Y306 (P1)</b>

Suitable for
<input type="checkbox"/> Temperature sensor
<input checked="" type="checkbox"/> Immersion heater
<input type="checkbox"/> Finned heater
<input checked="" type="checkbox"/> Thermostat
<input type="checkbox"/> Level sensor
<input type="checkbox"/> Electronic board

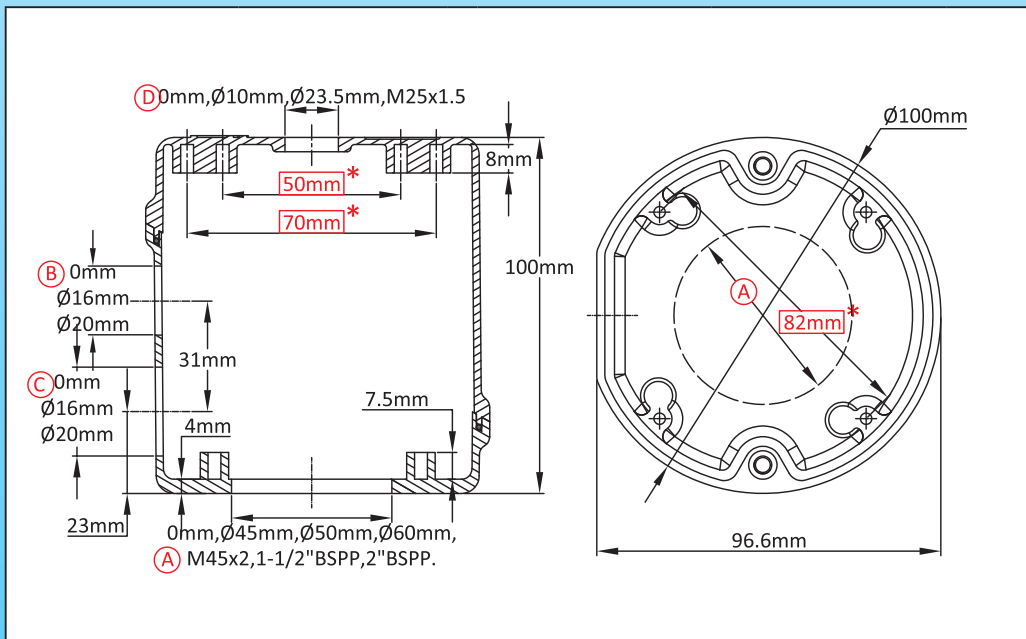

### Links

 Page (.pdf)

 Drawing 2D (.dwg)

 Drawing 3D (.stp)

## Main references

(A)(mm)	(B)(mm)	(C)(mm)	(D)(mm)	References	(A)(mm)	(B)(mm)	(C)(mm)	(D)(mm)	References
0	0	0	0	Y30600000000000T	0	16	20	0	Y30600002C00000T
0	0	0	10	Y306000A0000000T	0	16	20	10	Y306000A2C00000T
0	0	0	23.5	Y306000D0000000T	0	16	20	23.5	Y306000D2C00000T
0	0	0	M25x1.5	Y306000F0000000T	0	16	20	M25x1.5	Y306000F2C00000T
0	0	16	0	Y30600001160000T	0	20	20	0	Y30600002200000T
0	0	16	10	Y306000A1160000T	0	20	20	10	Y306000A2200000T
0	0	16	23.5	Y306000D1160000T	0	20	20	23.5	Y306000D2200000T
0	0	16	M25x1.5	Y306000F1160000T	0	20	20	M25x1.5	Y306000F2200000T
0	0	20	0	Y30600001200000T	45	0	0	0	Y30645000000000T
0	0	20	10	Y306000A1200000T	45	0	0	10	Y306450A0000000T
0	0	20	23.5	Y306000D1200000T	45	0	0	23.5	Y306450D0000000T
0	0	20	M25x1.5	Y306000F1200000T	45	0	0	M25x1.5	Y306450F0000000T
0	16	16	0	Y30600002160000T	45	0	16	0	Y30645001160000T
0	16	16	10	Y306000A2160000T	45	0	16	10	Y306450A1160000T
0	16	16	23.5	Y306000D2160000T	45	0	16	23.5	Y306450D1160000T
0	16	16	M25x1.5	Y306000F2160000T	45	0	16	M25x1.5	Y306450F1160000T

Cable gland not included in these reference, consult us if you want them.

Red dimensions inside rectangular frames on drawings are used for accessories assembly.



# Round enclosure for immersion heater or temperature sensor

**Y306**  
**(P2)**

A(mm)	B(mm)	C(mm)	D(mm)	References	A(mm)	B(mm)	C(mm)	D(mm)	References
45	0	20	0	Y30645001200000T	M45x2	0	16	0	Y306M4501600000T
45	0	20	10	Y306450A1200000T	M45x2	0	16	10	Y306M45A1600000T
45	0	20	23.5	Y306450D1200000T	M45x2	0	16	23.5	Y306M45D1600000T
45	0	20	M25x1.5	Y306450F1200000T	M45x2	0	16	M25x1.5	Y306M45F1600000T
45	16	16	0	Y30645002160000T	M45x2	0	20	0	Y306M4501200000T
45	16	16	10	Y306450A2160000T	M45x2	0	20	10	Y306M45A1200000T
45	16	16	23.5	Y306450D2160000T	M45x2	0	20	23.5	Y306M45D1200000T
45	16	16	M25x1.5	Y306450F2160000T	M45x2	0	20	M25x1.5	Y306M45F1200000T
45	16	20	0	Y30645002C00000T	M45x2	16	16	0	Y306M4502160000T
45	16	20	10	Y306450A2C00000T	M45x2	16	16	10	Y306M45A2160000T
45	16	20	23.5	Y306450D2C00000T	M45x2	16	16	23.5	Y306M45D2160000T
45	16	20	M25x1.5	Y306450F2C00000T	M45x2	16	16	M25x1.5	Y306M45F2160000T
45	20	20	0	Y30645002200000T	M45x2	16	20	0	Y306M4502C00000T
45	20	20	10	Y306450A2200000T	M45x2	16	20	10	Y306M45A2C00000T
45	20	20	23.5	Y306450D2200000T	M45x2	16	20	23.5	Y306M45D2C00000T
45	20	20	M25x1.5	Y306450F2200000T	M45x2	16	20	M25x1.5	Y306M45F2C00000T
50	0	0	0	Y306500000000000T	M45x2	20	20	0	Y306M4502200000T
50	0	0	10	Y306500A00000000T	M45x2	20	20	10	Y306M45A2200000T
50	0	0	23.5	Y306500D00000000T	M45x2	20	20	23.5	Y306M45D2200000T
50	0	0	M25x1.5	Y306500F00000000T	M45x2	20	20	M25x1.5	Y306M45F2200000T
50	0	16	0	Y30650001600000T	1½"BSPP	0	0	0	Y306BA200000000T
50	0	16	10	Y306500A1600000T	1½"BSPP	0	0	10	Y306BA2A0000000T
50	0	16	23.5	Y306500D1600000T	1½"BSPP	0	0	23.5	Y306BA2D0000000T
50	0	16	M25x1.5	Y306500F1600000T	1½"BSPP	0	0	M25x1.5	Y306BA2F0000000T
50	0	20	0	Y30650001200000T	1½"BSPP	0	16	0	Y306BA201160000T
50	0	20	10	Y306500A1200000T	1½"BSPP	0	16	10	Y306BA2A1160000T
50	0	20	23.5	Y306500D1200000T	1½"BSPP	0	16	23.5	Y306BA2D1160000T
50	0	20	M25x1.5	Y306500F1200000T	1½"BSPP	0	16	M25x1.5	Y306BA2F1160000T
50	16	16	0	Y30650002160000T	1½"BSPP	0	20	0	Y306BA201200000T
50	16	16	10	Y306500A2160000T	1½"BSPP	0	20	10	Y306BA2A1200000T
50	16	16	23.5	Y306500D2160000T	1½"BSPP	0	20	23.5	Y306BA2D1200000T
50	16	16	M25x1.5	Y306500F2160000T	1½"BSPP	0	20	M25x1.5	Y306BA2F1200000T
50	16	20	0	Y30650002C00000T	1½"BSPP	16	16	0	Y306BA202160000T
50	16	20	10	Y306500A2C00000T	1½"BSPP	16	16	10	Y306BA2A2160000T
50	16	20	23.5	Y306500D2C00000T	1½"BSPP	16	16	23.5	Y306BA2D2160000T
50	16	20	M25x1.5	Y306500F2C00000T	1½"BSPP	16	16	M25x1.5	Y306BA2F2160000T
50	20	20	0	Y30650002200000T	1½"BSPP	16	20	0	Y306BA202C00000T
50	20	20	10	Y306500A2200000T	1½"BSPP	16	20	10	Y306BA2A2C00000T
50	20	20	23.5	Y306500D2200000T	1½"BSPP	16	20	23.5	Y306BA2D2C00000T
50	20	20	M25x1.5	Y306500F2200000T	1½"BSPP	16	20	M25x1.5	Y306BA2F2C00000T
60	0	0	0	Y306600000000000T	1½"BSPP	20	20	0	Y306BA202200000T
60	0	0	10	Y306600A00000000T	1½"BSPP	20	20	10	Y306BA2A2200000T
60	0	0	23.5	Y306600D00000000T	1½"BSPP	20	20	23.5	Y306BA2D2200000T
60	0	0	M25x1.5	Y306600F00000000T	1½"BSPP	20	20	M25x1.5	Y306BA2F2200000T
60	0	16	0	Y30660001160000T	2"BSPP	0	0	0	Y306BB200000000T
60	0	16	10	Y306600A1160000T	2"BSPP	0	0	10	Y306BB2A0000000T
60	0	16	23.5	Y306600D1160000T	2"BSPP	0	0	23.5	Y306BB2D0000000T
60	0	16	M25x1.5	Y306600F1160000T	2"BSPP	0	0	M25x1.5	Y306BB2F0000000T
60	0	20	0	Y30660001200000T	2"BSPP	0	16	0	Y306BB201160000T
60	0	20	10	Y306600A1200000T	2"BSPP	0	16	10	Y306BB2A1160000T
60	0	20	23.5	Y306600D1200000T	2"BSPP	0	16	23.5	Y306BB2D1160000T
60	0	20	M25x1.5	Y306600F1200000T	2"BSPP	0	16	M25x1.5	Y306BB2F1160000T
60	16	16	0	Y30660002160000T	2"BSPP	0	20	0	Y306BB201200000T
60	16	16	10	Y306600A2160000T	2"BSPP	0	20	10	Y306BB2A1200000T
60	16	16	23.5	Y306600D2160000T	2"BSPP	0	20	23.5	Y306BB2D1200000T
60	16	16	M25x1.5	Y306600F2160000T	2"BSPP	0	20	M25x1.5	Y306BB2F1200000T
60	16	20	0	Y30660002C00000T	2"BSPP	16	16	0	Y306BB202160000T
60	16	20	10	Y306600A2C00000T	2"BSPP	16	16	10	Y306BB2A2160000T
60	16	20	23.5	Y306600D2C00000T	2"BSPP	16	16	23.5	Y306BB2D2160000T
60	16	20	M25x1.5	Y306600F2C00000T	2"BSPP	16	16	M25x1.5	Y306BB2F2160000T
60	20	20	0	Y30660002200000T	2"BSPP	16	20	0	Y306BB202C00000T
60	20	20	10	Y306600A2200000T	2"BSPP	16	20	10	Y306BB2A2C00000T
60	20	20	23.5	Y306600D2200000T	2"BSPP	16	20	23.5	Y306BB2D2C00000T
60	20	20	M25x1.5	Y306600F2200000T	2"BSPP	16	20	M25x1.5	Y306BB2F2C00000T
M45x2	0	0	0	Y306M45000000000T	2"BSPP	20	20	0	Y306BB202200000T
M45x2	0	0	10	Y306M45A00000000T	2"BSPP	20	20	10	Y306BB2A2200000T
M45x2	0	0	23.5	Y306M45D00000000T	2"BSPP	20	20	23.5	Y306BB2D2200000T
M45x2	0	0	M25x1.5	Y306M45F00000000T	2"BSPP	20	20	M25x1.5	Y306BB2F2200000T

Because of permanent improvement of our products, drawings, descriptions, features used on these data sheets are for guidance only and can be modified without prior advice

# Round enclosure for immersion heater or temperature sensor with extension

Size(mm)	Volume(cm <sup>3</sup> )	Material	Protection grade		Model
<b>Dia. 100 X 125</b>	<b>783</b>	<b>PA66</b>	<b>IP69K</b>	<b>IK10</b>	<b>Y3C4</b>

## Suitable for

- Temperature sensor
- Immersion heater
- Finned heater
- Thermostat
- Level sensor
- Electronic board

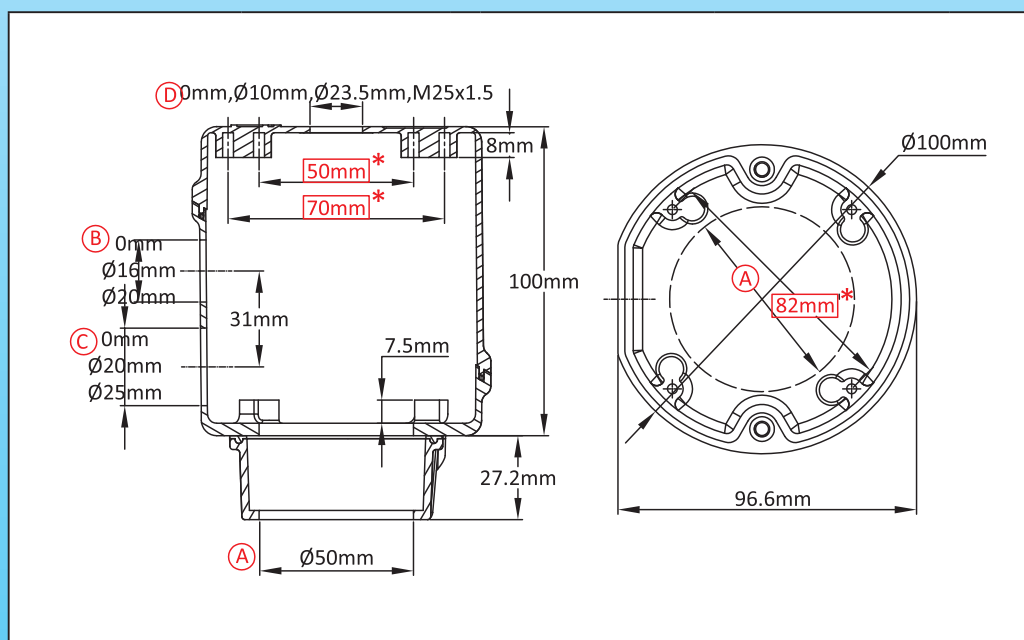

## Links



Page  
(.pdf)



Drawing 2D  
(.dwg)



Drawing 3D  
(.stp)

## Main references

Ⓐ(mm)	Ⓑ(mm)	Ⓒ(mm)	Ⓓ(mm)	References	Ⓐ(mm)	Ⓑ(mm)	Ⓒ(mm)	Ⓓ(mm)	References
50	0	0	0	Y3C45000000000T	50	16	20	0	Y3C450002C00000T
50	0	0	10	Y3C4500A000000T	50	16	20	10	Y3C4500A2C00000T
50	0	0	23.5	Y3C4500D000000T	50	16	20	23.5	Y3C4500D2C00000T
50	0	0	M25x1.5	Y3C4500F000000T	50	16	20	M25x1.5	Y3C4500F2C00000T
50	0	20	0	Y3C450001200000T	50	16	25	0	Y3C450002C50000T
50	0	20	10	Y3C4500A1200000T	50	16	25	10	Y3C4500A2C50000T
50	0	20	23.5	Y3C4500D1200000T	50	16	25	23.5	Y3C4500D2C50000T
50	0	20	M25x1.5	Y3C4500F1200000T	50	16	25	M25x1.5	Y3C4500F2C50000T
50	0	25	0	Y3C450001250000T	50	20	20	0	Y3C450002200000T
50	0	25	10	Y3C4500A1250000T	50	20	20	10	Y3C4500A2200000T
50	0	25	23.5	Y3C4500D1250000T	50	20	20	23.5	Y3C4500D2200000T
50	0	25	M25x1.5	Y3C4500F1250000T	50	20	20	M25x1.5	Y3C4500F2200000T
50	16	0	0	Y3C450001160000T	50	20	25	0	Y3C450002D50000T
50	16	0	10	Y3C4500A1160000T	50	20	25	10	Y3C4500A2D50000T
50	16	0	23.5	Y3C4500D1160000T	50	20	25	23.5	Y3C4500D2D50000T
50	16	0	M25x1.5	Y3C4500F1160000T	50	20	25	M25x1.5	Y3C4500F2D50000T

Cable gland not included in these reference, consult us if you want them.

Red dimensions inside rectangular frames on drawings are used for accessories assembly.

# Wall mounting temperature sensor enclosure. In PA66 and polycarbonate

Size(mm)	Volume(cm <sup>3</sup> )	Material	Protection grade		Model
Dia. 105 X 66	500	PA66 + PC	IP69K	IK10	<b>Y3F1</b>

Suitable for	
<input checked="" type="checkbox"/> Temperature sensor	
<input type="checkbox"/> Immersion heater	
<input type="checkbox"/> Finned heater	
<input checked="" type="checkbox"/> Thermostat	
<input type="checkbox"/> Level sensor	
<input type="checkbox"/> Electronic board	

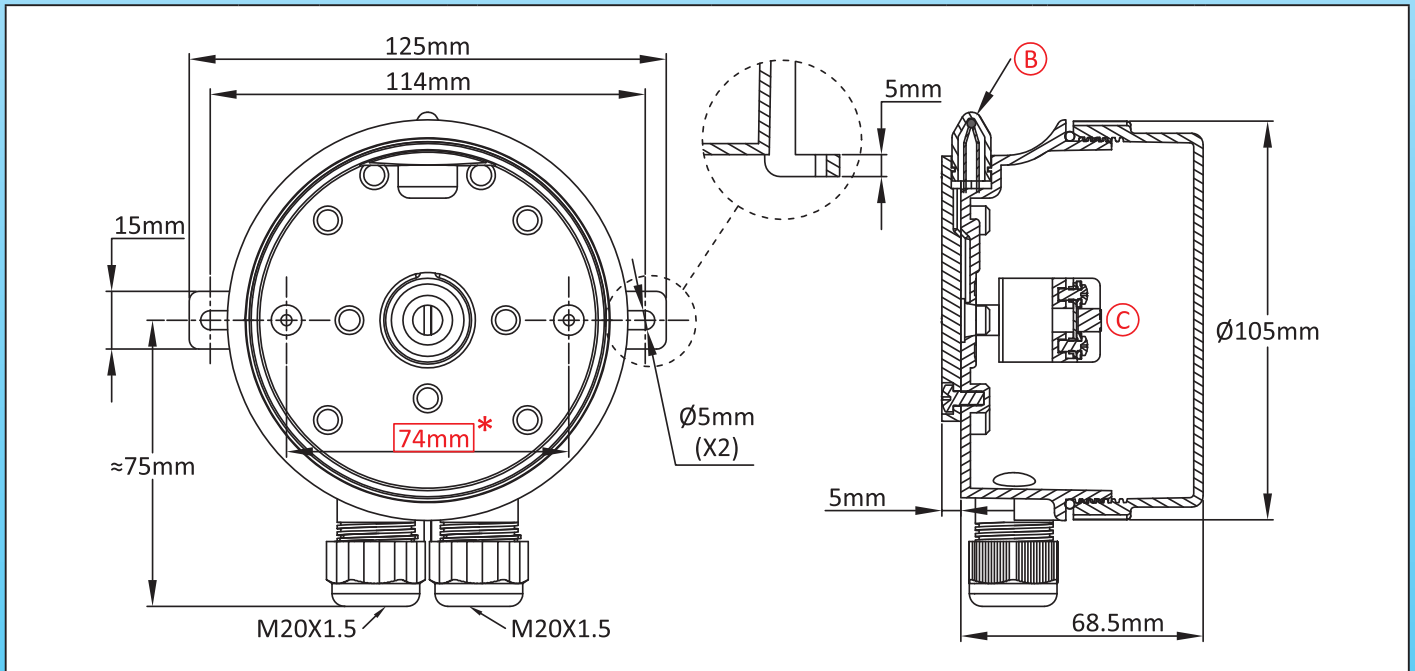

## Main references

With connection block	Without connection block
Y3F1000022AH400T	Y3F1000022A0000T

## Links

		Page (.pdf)
		Drawing 2D (.dwg)
		Drawing 3D (.stp)

Cable gland not included in these reference, consult us if you want them.

Red dimensions inside rectangular frames on drawings are used for accessories assembly.

Because of permanent improvement of our products, drawings, descriptions, features used on these data sheets are for guidance only and can be modified without prior advice

# Immersion heater, level sensor or temperature sensor enclosure. In PA66 and polycarbonate

Size(mm)	Volume(cm <sup>3</sup> )	Material	Protection grade		Model
Dia. 105 X 66	500	PA66 + PC	IP69K	IK10	<b>Y3F2</b>

Suitable for
<input checked="" type="checkbox"/> Temperature sensor
<input checked="" type="checkbox"/> Immersion heater
<input type="checkbox"/> Finned heater
<input checked="" type="checkbox"/> Thermostat
<input checked="" type="checkbox"/> Level sensor
<input type="checkbox"/> Electronic board

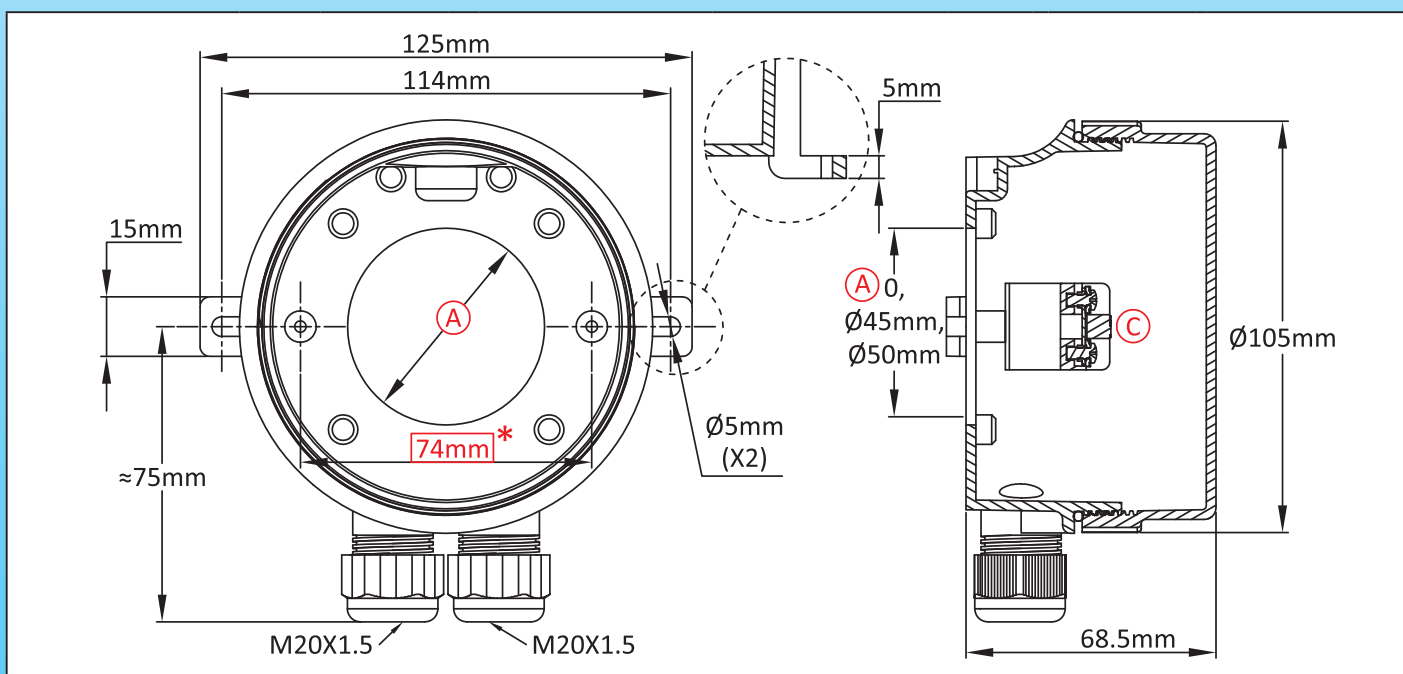

## Main references

Ⓐ(mm)	With connection block Ⓒ	Without connection block Ⓒ
0	Y3F2000022AH400T	Y3F2000022A0000T
45	Y3F2450022AH400T	Y3F2450022A0000T
50	Y3F2500022AH400T	Y3F2500022A0000T

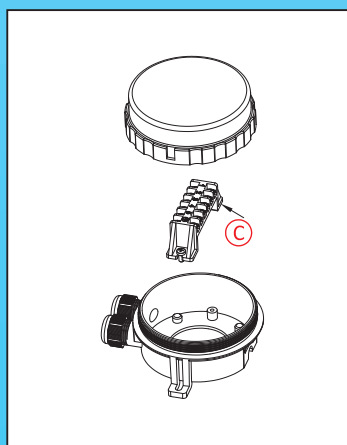

## Links

	Page (.pdf)
	Drawing 2D (.dwg)
	Drawing 3D (.stp)

Cable gland not included in these reference, consult us if you want them.

Red dimensions inside rectangular frames on drawings are used for accessories assembly.

# Immersion heater enclosure with extension. In PA66 and polycarbonate

Size(mm)	Volume(cm <sup>3</sup> )	Material	Protection grade		Model
Dia. 105 X 87	583	PA66 + PC	IP69K	IK10	<b>Y3F3</b>

Suitable for
<input type="checkbox"/> Temperature sensor
<input checked="" type="checkbox"/> Immersion heater
<input type="checkbox"/> Finned heater
<input checked="" type="checkbox"/> Thermostat
<input type="checkbox"/> Level sensor
<input type="checkbox"/> Electronic board

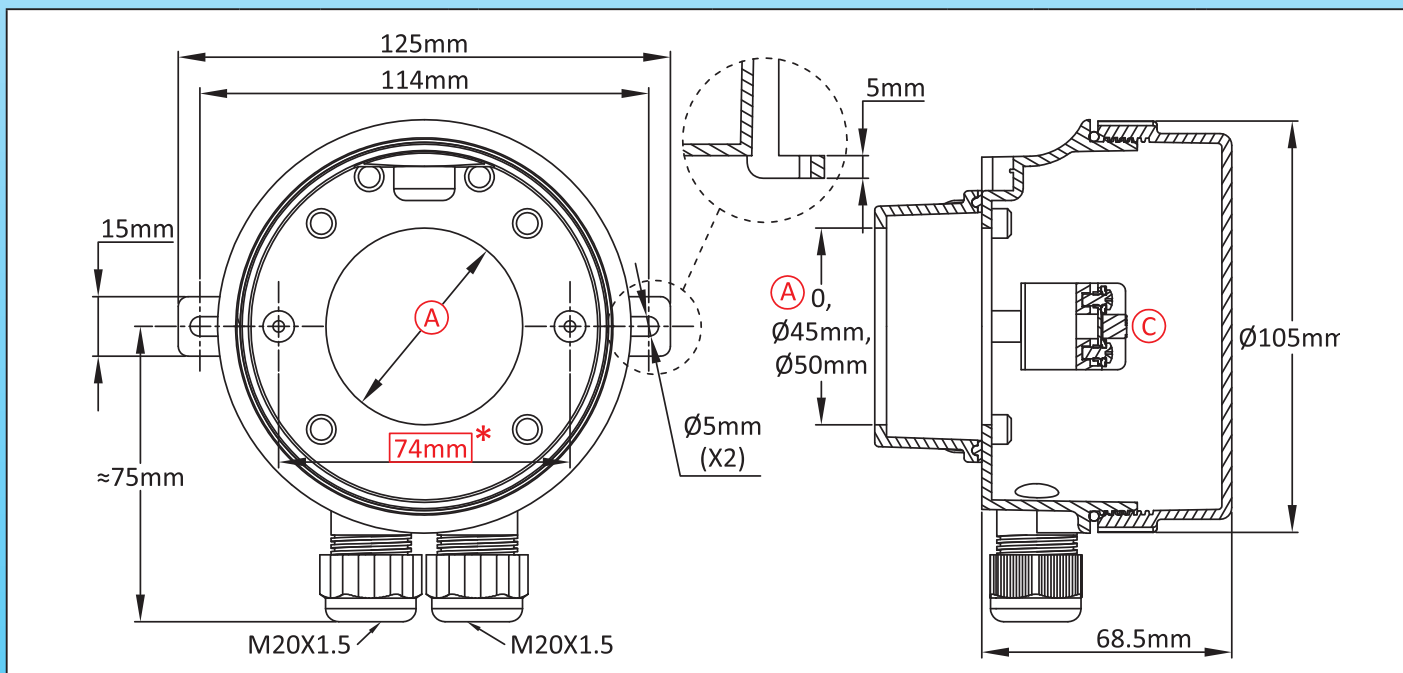

## Main references

With connection block <span style="color:red">ⓐ</span>	Without connection block <span style="color:red">ⓐ</span>
Y3F3500022AH400T	Y3F3500022A0000T

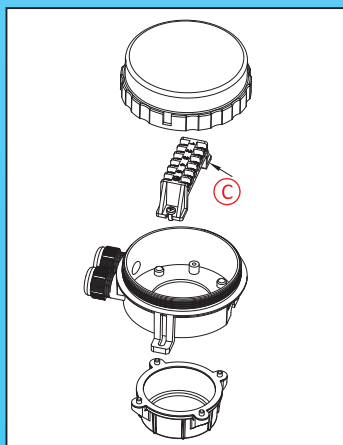

## Links

	Page (.pdf)
	Drawing 2D (.dwg)
	Drawing 3D (.stp)

Cable gland not included in these reference, consult us if you want them.

Red dimensions inside rectangular frames on drawings are used for accessories assembly.

# Big size enclosure for immersion heater, temperature sensor, level sensor or controls

Size(mm)	Volume(cm <sup>3</sup> )	Material	Protection grade		Model
<b>130 X 130 X 150</b>	<b>2530</b>	<b>PA66</b>	<b>IP69K</b>	<b>IK10</b>	<b>Y307 (P1)</b>

Suitable for
<input type="checkbox"/> Temperature sensor
<input checked="" type="checkbox"/> Immersion heater
<input type="checkbox"/> Finned heater
<input checked="" type="checkbox"/> Thermostat
<input type="checkbox"/> Level sensor
<input checked="" type="checkbox"/> Electronic board

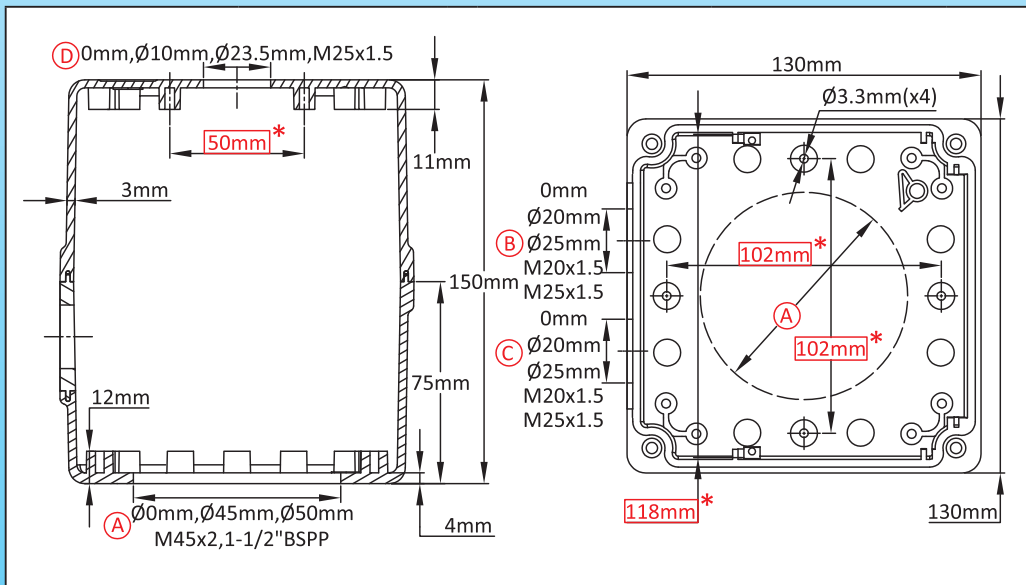

### Links

- Page (.pdf)
- Drawing 2D (.dwg)
- Drawing 3D (.stp)

## Main references

A(mm)	B(mm)	C(mm)	D(mm)	References	A(mm)	B(mm)	C(mm)	D(mm)	References
0	0	0	0	Y30700000000000T	0	20	20	10	Y307000A2200000T
0	0	0	10	Y307000A0000000T	0	20	20	23.5	Y307000D2200000T
0	0	0	23.5	Y307000D0000000T	0	20	20	M25x1.5	Y307000F2200000T
0	0	0	M25x1.5	Y307000F0000000T	0	25	25	0	Y30700002250000T
0	0	20	0	Y30700001200000T	0	25	25	10	Y307000A2250000T
0	0	20	10	Y307000A1200000T	0	25	25	23.5	Y307000D2250000T
0	0	20	23.5	Y307000D1200000T	0	25	25	M25x1.5	Y307000F2250000T
0	0	20	M25x1.5	Y307000F1200000T	0	M20x1.5	M20x1.5	0	Y30700002T00000T
0	0	25	0	Y30700001250000T	0	M20x1.5	M20x1.5	10	Y307000A2T00000T
0	0	25	10	Y307000A1250000T	0	M20x1.5	M20x1.5	23.5	Y307000D2T00000T
0	0	25	23.5	Y307000D1250000T	0	M20x1.5	M20x1.5	M25x1.5	Y307000F2T00000T
0	0	25	M25x1.5	Y307000F1250000T	0	M25x1.5	M25x1.5	0	Y30700002T50000T
0	0	M20x1.5	0	Y30700001T00000T	0	M25x1.5	M25x1.5	10	Y307000A2T50000T
0	0	M20x1.5	10	Y307000A1T00000T	0	M25x1.5	M25x1.5	23.5	Y307000D2T50000T
0	0	M20x1.5	23.5	Y307000D1T00000T	0	M25x1.5	M25x1.5	M25x1.5	Y307000F2T50000T
0	0	M20x1.5	M25x1.5	Y307000F1T00000T	45	0	0	0	Y30745000000000T
0	0	M25x1.5	0	Y30700001T50000T	45	0	0	10	Y307450A0000000T
0	0	M25x1.5	10	Y307000A1T50000T	45	0	0	23.5	Y307450D0000000T
0	0	M25x1.5	23.5	Y307000D1T50000T	45	0	0	M25x1.5	Y307450F0000000T
0	0	M25x1.5	M25x1.5	Y307000F1T50000T	45	0	20	0	Y30745001200000T
0	20	20	0	Y30700002200000T	45	0	20	10	Y307450A1200000T

Cable gland not included in these reference, consult us if you want them.

Red dimensions inside rectangular frames on drawings are used for accessories assembly.

# Big size enclosure for immersion heater, temperature sensor, level sensor or controls

**Y307**  
**(P2)**

A(mm)	B(mm)	C(mm)	D(mm)	References	A(mm)	B(mm)	C(mm)	D(mm)	References
45	0	20	23.5	Y307450D1200000T	M45x2	0	0	M25x1.5	Y307M45F0000000T
45	0	20	M25x1.5	Y307450F1200000T	M45x2	0	20	0	Y307M4501200000T
45	0	25	0	Y30745001250000T	M45x2	0	20	10	Y307M45A1200000T
45	0	25	10	Y307450A1250000T	M45x2	0	20	23.5	Y307M45D1200000T
45	0	25	23.5	Y307450D1250000T	M45x2	0	20	M25x1.5	Y307M45F1200000T
45	0	25	M25x1.5	Y307450F1250000T	M45x2	0	25	0	Y307M4501250000T
45	0	M20x1.5	0	Y30745001T00000T	M45x2	0	25	10	Y307M45A1250000T
45	0	M20x1.5	10	Y307450A1T00000T	M45x2	0	25	23.5	Y307M45D1250000T
45	0	M20x1.5	23.5	Y307450D1T00000T	M45x2	0	25	M25x1.5	Y307M45F1250000T
45	0	M20x1.5	M25x1.5	Y307450F1T00000T	M45x2	0	M20x1.5	0	Y307M4501T00000T
45	0	M25x1.5	0	Y30745001T50000T	M45x2	0	M20x1.5	10	Y307M45A1T00000T
45	0	M25x1.5	10	Y307450A1T50000T	M45x2	0	M20x1.5	23.5	Y307M45D1T00000T
45	0	M25x1.5	23.5	Y307450D1T50000T	M45x2	0	M20x1.5	M25x1.5	Y307M45F1T00000T
45	0	M25x1.5	M25x1.5	Y307450F1T50000T	M45x2	0	M25x1.5	0	Y307M4501T50000T
45	20	20	0	Y30745002200000T	M45x2	0	M25x1.5	10	Y307M45A1T50000T
45	20	20	10	Y307450A2200000T	M45x2	0	M25x1.5	23.5	Y307M45D1T50000T
45	20	20	23.5	Y307450D2200000T	M45x2	0	M25x1.5	M25x1.5	Y307M45F1T50000T
45	20	20	M25x1.5	Y307450F2200000T	M45x2	20	20	0	Y307M4502200000T
45	25	25	0	Y30745002250000T	M45x2	20	20	10	Y307M45A2200000T
45	25	25	10	Y307450A2250000T	M45x2	20	20	23.5	Y307M45D2200000T
45	25	25	23.5	Y307450D2250000T	M45x2	20	20	M25x1.5	Y307M45F2200000T
45	25	25	M25x1.5	Y307450F2250000T	M45x2	25	25	0	Y307M4502250000T
45	M20x1.5	M20x1.5	0	Y30745002T00000T	M45x2	25	25	10	Y307M45A2250000T
45	M20x1.5	M20x1.5	10	Y307450A2T00000T	M45x2	25	25	23.5	Y307M45D2250000T
45	M20x1.5	M20x1.5	23.5	Y307450D2T00000T	M45x2	25	25	M25x1.5	Y307M45F2250000T
45	M20x1.5	M20x1.5	M25x1.5	Y307450F2T00000T	M45x2	M20x1.5	M20x1.5	0	Y307M4502T00000T
45	M25x1.5	M25x1.5	0	Y30745002T50000T	M45x2	M20x1.5	M20x1.5	10	Y307M45A2T00000T
45	M25x1.5	M25x1.5	10	Y307450A2T50000T	M45x2	M20x1.5	M20x1.5	23.5	Y307M45D2T00000T
45	M25x1.5	M25x1.5	23.5	Y307450D2T50000T	M45x2	M20x1.5	M20x1.5	M25x1.5	Y307M45F2T00000T
45	M25x1.5	M25x1.5	M25x1.5	Y307450F2T50000T	M45x2	M25x1.5	M25x1.5	0	Y307M4502T50000T
50	0	0	0	Y307500000000000T	M45x2	M25x1.5	M25x1.5	10	Y307M45A2T50000T
50	0	0	10	Y307500A00000000T	M45x2	M25x1.5	M25x1.5	23.5	Y307M45D2T50000T
50	0	0	23.5	Y307500D00000000T	M45x2	M25x1.5	M25x1.5	M25x1.5	Y307M45F2T50000T
50	0	0	M25x1.5	Y307500F00000000T	1½"BSPP	0	0	0	Y307BA200000000T
50	0	20	0	Y30750001200000T	1½"BSPP	0	0	10	Y307BA2A0000000T
50	0	20	10	Y307500A1200000T	1½"BSPP	0	0	23.5	Y307BA2D0000000T
50	0	20	23.5	Y307500D1200000T	1½"BSPP	0	0	M25x1.5	Y307BA2F0000000T
50	0	20	M25x1.5	Y307500F1200000T	1½"BSPP	0	20	0	Y307BA201200000T
50	0	25	0	Y30750001250000T	1½"BSPP	0	20	10	Y307BA2A1200000T
50	0	25	10	Y307500A1250000T	1½"BSPP	0	20	23.5	Y307BA2D1200000T
50	0	25	23.5	Y307500D1250000T	1½"BSPP	0	20	M25x1.5	Y307BA2F1200000T
50	0	25	M25x1.5	Y307500F1250000T	1½"BSPP	0	25	0	Y307BA201250000T
50	0	M20x1.5	0	Y30750001T00000T	1½"BSPP	0	25	10	Y307BA2A1250000T
50	0	M20x1.5	10	Y307500A1T00000T	1½"BSPP	0	25	23.5	Y307BA2D1250000T
50	0	M20x1.5	23.5	Y307500D1T00000T	1½"BSPP	0	25	M25x1.5	Y307BA2F1250000T
50	0	M20x1.5	M25x1.5	Y307500F1T00000T	1½"BSPP	0	M20x1.5	0	Y307BA201T00000T
50	0	M25x1.5	0	Y30750001T50000T	1½"BSPP	0	M20x1.5	10	Y307BA2A1T00000T
50	0	M25x1.5	10	Y307500A1T50000T	1½"BSPP	0	M20x1.5	23.5	Y307BA2D1T00000T
50	0	M25x1.5	23.5	Y307500D1T50000T	1½"BSPP	0	M20x1.5	M25x1.5	Y307BA2F1T00000T
50	0	M25x1.5	M25x1.5	Y307500F1T50000T	1½"BSPP	0	M25x1.5	0	Y307BA201T50000T
50	20	20	0	Y30750002200000T	1½"BSPP	0	M25x1.5	10	Y307BA2A1T50000T
50	20	20	10	Y307500A2200000T	1½"BSPP	0	M25x1.5	23.5	Y307BA2D1T50000T
50	20	20	23.5	Y307500D2200000T	1½"BSPP	0	M25x1.5	M25x1.5	Y307BA2F1T50000T
50	20	20	M25x1.5	Y307500F2200000T	1½"BSPP	20	20	0	Y307BA202200000T
50	25	25	0	Y30750002250000T	1½"BSPP	20	20	10	Y307BA2A2200000T
50	25	25	10	Y307500A2250000T	1½"BSPP	20	20	23.5	Y307BA2D2200000T
50	25	25	23.5	Y307500D2250000T	1½"BSPP	20	20	M25x1.5	Y307BA2F2200000T
50	25	25	M25x1.5	Y307500F2250000T	1½"BSPP	25	25	0	Y307BA202250000T
50	M20x1.5	M20x1.5	0	Y30750002T00000T	1½"BSPP	25	25	10	Y307BA2A2250000T
50	M20x1.5	M20x1.5	10	Y307500A2T00000T	1½"BSPP	25	25	23.5	Y307BA2D2250000T
50	M20x1.5	M20x1.5	23.5	Y307500D2T00000T	1½"BSPP	25	25	M25x1.5	Y307BA2F2250000T
50	M20x1.5	M20x1.5	M25x1.5	Y307500F2T00000T	1½"BSPP	M20x1.5	M20x1.5	0	Y307BA202T00000T
50	M25x1.5	M25x1.5	0	Y30750002T50000T	1½"BSPP	M20x1.5	M20x1.5	10	Y307BA2A2T00000T
50	M25x1.5	M25x1.5	10	Y307500A2T50000T	1½"BSPP	M20x1.5	M20x1.5	23.5	Y307BA2D2T00000T
50	M25x1.5	M25x1.5	23.5	Y307500D2T50000T	1½"BSPP	M20x1.5	M20x1.5	M25x1.5	Y307BA2F2T00000T
50	M25x1.5	M25x1.5	M25x1.5	Y307500F2T50000T	1½"BSPP	M25x1.5	M25x1.5	0	Y307BA202T50000T
M45x2	0	0	0	Y307M45000000000T	1½"BSPP	M25x1.5	M25x1.5	10	Y307BA2A2T50000T
M45x2	0	0	10	Y307M45A00000000T	1½"BSPP	M25x1.5	M25x1.5	23.5	Y307BA2D2T50000T
M45x2	0	0	23.5	Y307M45D00000000T	1½"BSPP	M25x1.5	M25x1.5	M25x1.5	Y307BA2F2T50000T

Because of permanent improvement of our products, drawings, descriptions, features used on these data sheets are for guidance only and can be modified without prior advice

## Big size enclosure with extension, for immersion heater

Size(mm)	Volume(cm <sup>3</sup> )	Material	Protection grade		Model
<b>130 X 130 X 190</b>	<b>2836</b>	<b>PA66</b>	<b>IP69K</b>	<b>IK10</b>	<b>Y3M1</b> <span style="color: red;">(P1)</span>

Suitable for
<input type="checkbox"/> Temperature sensor
<input checked="" type="checkbox"/> Immersion heater
<input type="checkbox"/> Finned heater
<input checked="" type="checkbox"/> Thermostat
<input type="checkbox"/> Level sensor
<input checked="" type="checkbox"/> Electronic board

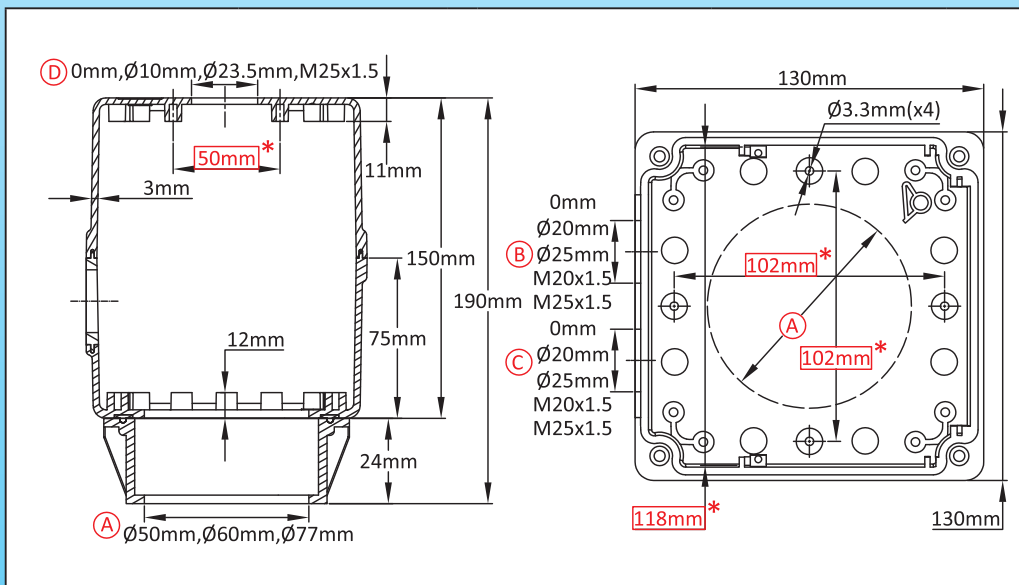

### Links

Page  
(.pdf)

Drawing 2D  
(.dwg)

Drawing 3D  
(.stp)

### Main references

(A)(mm)	(B)(mm)	(C)(mm)	(D)(mm)	References	(A)(mm)	(B)(mm)	(C)(mm)	(D)(mm)	References
50	0	0	0	Y3M150000000000T	50	20	20	10	Y3M1500A2200000T
50	0	0	10	Y3M1500A0000000T	50	20	20	23.5	Y3M1500D2200000T
50	0	0	23.5	Y3M1500D0000000T	50	20	20	M25x1.5	Y3M1500F2200000T
50	0	0	M25x1.5	Y3M1500F0000000T	50	25	25	0	Y3M150002250000T
50	0	20	0	Y3M150001200000T	50	25	25	10	Y3M1500A2250000T
50	0	20	10	Y3M1500A1200000T	50	25	25	23.5	Y3M1500D2250000T
50	0	20	23.5	Y3M1500D1200000T	50	25	25	M25x1.5	Y3M1500F2250000T
50	0	20	M25x1.5	Y3M1500F1200000T	50	M20x1.5	M20x1.5	0	Y3M150002T00000T
50	0	25	0	Y3M150001250000T	50	M20x1.5	M20x1.5	10	Y3M1500A2T00000T
50	0	25	10	Y3M1500A1250000T	50	M20x1.5	M20x1.5	23.5	Y3M1500D2T00000T
50	0	25	23.5	Y3M1500D1250000T	50	M20x1.5	M20x1.5	M25x1.5	Y3M1500F2T00000T
50	0	25	M25x1.5	Y3M1500F1250000T	50	M25x1.5	M25x1.5	0	Y3M150002T50000T
50	0	M20x1.5	0	Y3M150001T00000T	50	M25x1.5	M25x1.5	10	Y3M1500A2T50000T
50	0	M20x1.5	10	Y3M1500A1T00000T	50	M25x1.5	M25x1.5	23.5	Y3M1500D2T50000T
50	0	M20x1.5	23.5	Y3M1500D1T00000T	50	M25x1.5	M25x1.5	M25x1.5	Y3M1500F2T50000T
50	0	M20x1.5	M25x1.5	Y3M1500F1T00000T	60	0	0	0	Y3M160000000000T
50	0	M25x1.5	0	Y3M150001T50000T	60	0	0	10	Y3M1600A0000000T
50	0	M25x1.5	10	Y3M1500A1T50000T	60	0	0	23.5	Y3M1600D0000000T
50	0	M25x1.5	23.5	Y3M1500D1T50000T	60	0	0	M25x1.5	Y3M1600F0000000T
50	0	M25x1.5	M25x1.5	Y3M1500F1T50000T	60	0	20	0	Y3M160001200000T
50	20	20	0	Y3M150002200000T	60	0	20	10	Y3M1600A1200000T

Cable gland not included in these reference, consult us if you want them.

Red dimensions inside rectangular frames on drawings are used for accessories assembly.



# Big size enclosure with extension, for immersion heater

**Y3M1**  
**(P2)**

A (mm)	B (mm)	C (mm)	D (mm)	References	A (mm)	B (mm)	C (mm)	D (mm)	References
60	0	20	23.5	Y3M1600D1200000T	77	0	0	M25×1.5	Y3M1770F0000000T
60	0	20	M25×1.5	Y3M1600F1200000T	77	0	20	0	Y3M177001200000T
60	0	25	0	Y3M160001250000T	77	0	20	10	Y3M1770A1200000T
60	0	25	10	Y3M1600A1250000T	77	0	20	23.5	Y3M1770D1200000T
60	0	25	23.5	Y3M1600D1250000T	77	0	20	M25×1.5	Y3M1770F1200000T
60	0	25	M25×1.5	Y3M1600F1250000T	77	0	25	0	Y3M177001250000T
60	0	M20×1.5	0	Y3M160001T00000T	77	0	25	10	Y3M1770A1250000T
60	0	M20×1.5	10	Y3M1600A1T00000T	77	0	25	23.5	Y3M1770D1250000T
60	0	M20×1.5	23.5	Y3M1600D1T00000T	77	0	25	M25×1.5	Y3M1770F1250000T
60	0	M20×1.5	M25×1.5	Y3M1600F1T00000T	77	0	M20×1.5	0	Y3M177001T00000T
60	0	M25×1.5	0	Y3M160001T50000T	77	0	M20×1.5	10	Y3M1770A1T00000T
60	0	M25×1.5	10	Y3M1600A1T50000T	77	0	M20×1.5	23.5	Y3M1770D1T00000T
60	0	M25×1.5	23.5	Y3M1600D1T50000T	77	0	M20×1.5	M25×1.5	Y3M1770F1T00000T
60	0	M25×1.5	M25×1.5	Y3M1600F1T50000T	77	0	M25×1.5	0	Y3M177001T50000T
60	20	20	0	Y3M160002200000T	77	0	M25×1.5	10	Y3M1770A1T50000T
60	20	20	10	Y3M1600A2200000T	77	0	M25×1.5	23.5	Y3M1770D1T50000T
60	20	20	23.5	Y3M1600D2200000T	77	0	M25×1.5	M25×1.5	Y3M1770F1T50000T
60	20	20	M25×1.5	Y3M1600F2200000T	77	20	20	0	Y3M177002200000T
60	25	25	0	Y3M160002250000T	77	20	20	10	Y3M1770A2200000T
60	25	25	10	Y3M1600A2250000T	77	20	20	23.5	Y3M1770D2200000T
60	25	25	23.5	Y3M1600D2250000T	77	20	20	M25×1.5	Y3M1770F2200000T
60	25	25	M25×1.5	Y3M1600F2250000T	77	25	25	0	Y3M177002250000T
60	M20×1.5	M20×1.5	0	Y3M160002T00000T	77	25	25	10	Y3M1770A2250000T
60	M20×1.5	M20×1.5	10	Y3M1600A2T00000T	77	25	25	23.5	Y3M1770D2250000T
60	M20×1.5	M20×1.5	23.5	Y3M1600D2T00000T	77	25	25	M25×1.5	Y3M1770F2250000T
60	M20×1.5	M20×1.5	M25×1.5	Y3M1600F2T00000T	77	M20×1.5	M20×1.5	0	Y3M177002T00000T
60	M25×1.5	M25×1.5	0	Y3M160002T50000T	77	M20×1.5	M20×1.5	10	Y3M1770A2T00000T
60	M25×1.5	M25×1.5	10	Y3M1600A2T50000T	77	M20×1.5	M20×1.5	23.5	Y3M1770D2T00000T
60	M25×1.5	M25×1.5	23.5	Y3M1600D2T50000T	77	M20×1.5	M20×1.5	M25×1.5	Y3M1770F2T00000T
60	M25×1.5	M25×1.5	M25×1.5	Y3M1600F2T50000T	77	M25×1.5	M25×1.5	0	Y3M177002T50000T
77	0	0	0	Y3M1770000000000T	77	M25×1.5	M25×1.5	10	Y3M1770A2T50000T
77	0	0	10	Y3M1770A00000000T	77	M25×1.5	M25×1.5	23.5	Y3M1770D2T50000T
77	0	0	23.5	Y3M1770D00000000T	77	M25×1.5	M25×1.5	M25×1.5	Y3M1770F2T50000T

Because of permanent improvement of our products, drawings, descriptions, features used on these data sheets are for guidance only and can be modified without prior advice

# Enclosure for controls, connection, temperature sensor, thermostat, level sensor. Removable wall mounting legs

Size(mm)	Volume(cm <sup>3</sup> )	Material	Protection grade		Model
<b>130 X 180 X 80</b>	<b>1870</b>	<b>PA66</b>	<b>IP69K</b>	<b>IK10</b>	<b>Y3N1</b>

Suitable for
<input type="checkbox"/> Temperature sensor
<input checked="" type="checkbox"/> Immersion heater
<input checked="" type="checkbox"/> Finned heater
<input checked="" type="checkbox"/> Thermostat
<input type="checkbox"/> Level sensor
<input checked="" type="checkbox"/> Electronic board

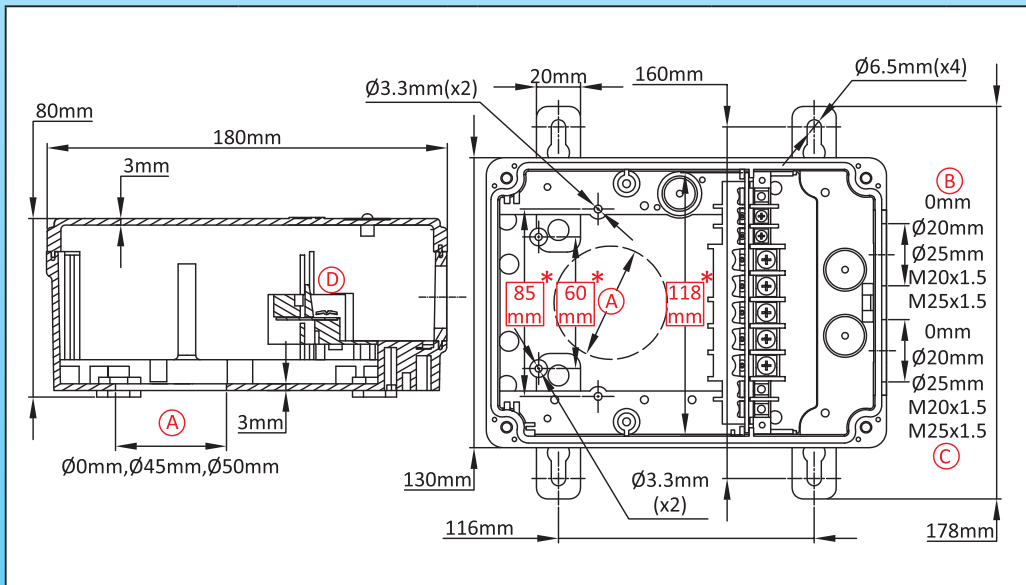
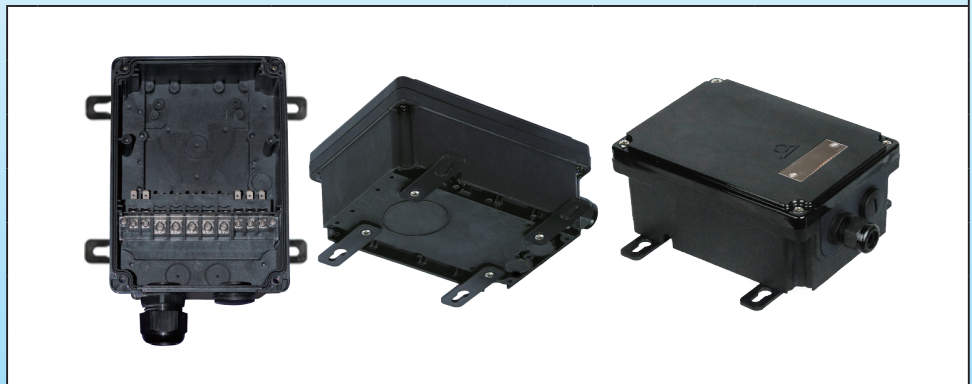

### Links

Page  
(.pdf)

Drawing 2D  
(.dwg)

Drawing 3D  
(.stp)

### Main references

Ⓐ(mm)	Ⓑ(mm)	Ⓒ(mm)	With connection block Ⓓ	Without connection block Ⓔ	Ⓐ(mm)	Ⓑ(mm)	Ⓒ(mm)	With connection block Ⓓ	Without connection block Ⓔ
0	0	0	Y3N10000000J100T	Y3N100000000000T	45	20	20	Y3N14500220J100T	Y3N145002200000T
0	0	20	Y3N10000120J100T	Y3N100001200000T	45	25	25	Y3N14500225J100T	Y3N145002250000T
0	0	25	Y3N10000125J100T	Y3N100001250000T	45	M20x1.5	M20x1.5	Y3N145002T0J100T	Y3N145002T00000T
0	0	M20x1.5	Y3N100001T0J100T	Y3N100001T00000T	45	M25x1.5	M25x1.5	Y3N145002T5J100T	Y3N145002T50000T
0	0	M25x1.5	Y3N100001T5J100T	Y3N100001T50000T	50	0	0	Y3N15000000J100T	Y3N150000000000T
0	20	20	Y3N10000220J100T	Y3N100002200000T	50	0	20	Y3N15000120J100T	Y3N150001200000T
0	25	25	Y3N10000225J100T	Y3N100002250000T	50	0	25	Y3N15000125J100T	Y3N150001250000T
0	M20x1.5	M20x1.5	Y3N100002T0J100T	Y3N100002T00000T	50	0	M20x1.5	Y3N150001T0J100T	Y3N150001T00000T
0	M25x1.5	M25x1.5	Y3N100002T5J100T	Y3N100002T50000T	50	0	M25x1.5	Y3N150001T5J100T	Y3N150001T50000T
45	0	0	Y3N14500000J100T	Y3N145000000000T	50	20	20	Y3N15000220J100T	Y3N150002200000T
45	0	20	Y3N14500120J100T	Y3N145001200000T	50	25	25	Y3N15000225J100T	Y3N150002250000T
45	0	25	Y3N14500125J100T	Y3N145001250000T	50	M20x1.5	M20x1.5	Y3N150002T0J100T	Y3N150002T00000T
45	0	M20x1.5	Y3N145001T0J100T	Y3N145001T00000T	50	M25x1.5	M25x1.5	Y3N150002T5J100T	Y3N150002T50000T
45	0	M25x1.5	Y3N145001T5J100T	Y3N145001T50000T					

Cable gland not included in these reference, consult us if you want them.

Red dimensions inside rectangular frames on drawings are used for accessories assembly.

## Enclosure with window, for controls, connection, temperature sensor, thermostat, level sensor, GFI, removable wall mounting legs

Size(mm)	Volume(cm <sup>3</sup> )	Material	Protection grade		Model
<b>130 X 180 X 95</b>	<b>2010</b>	<b>PA66 + PC</b>	<b>IP69K</b>	<b>IK10</b>	<b>Y3N2</b>

### Suitable for

- Temperature sensor
- Immersion heater
- Finned heater
- Thermostat
- Level sensor
- Electronic board

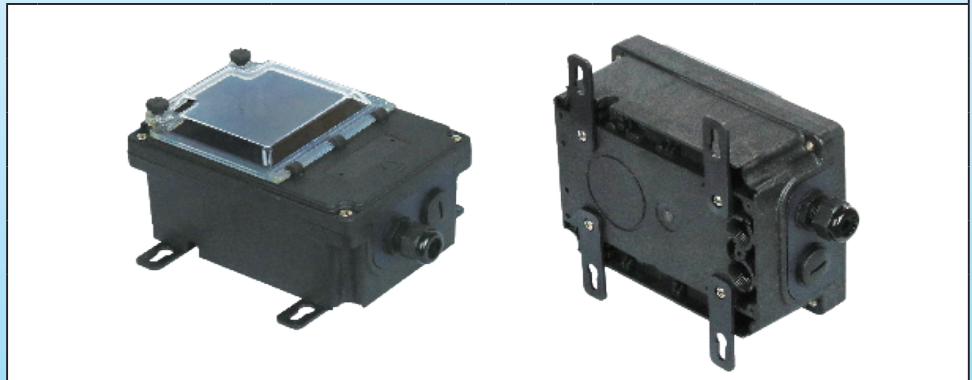

### Links



Page  
(.pdf)



Drawing 2D  
(.dwg)



Drawing 3D  
(.stp)

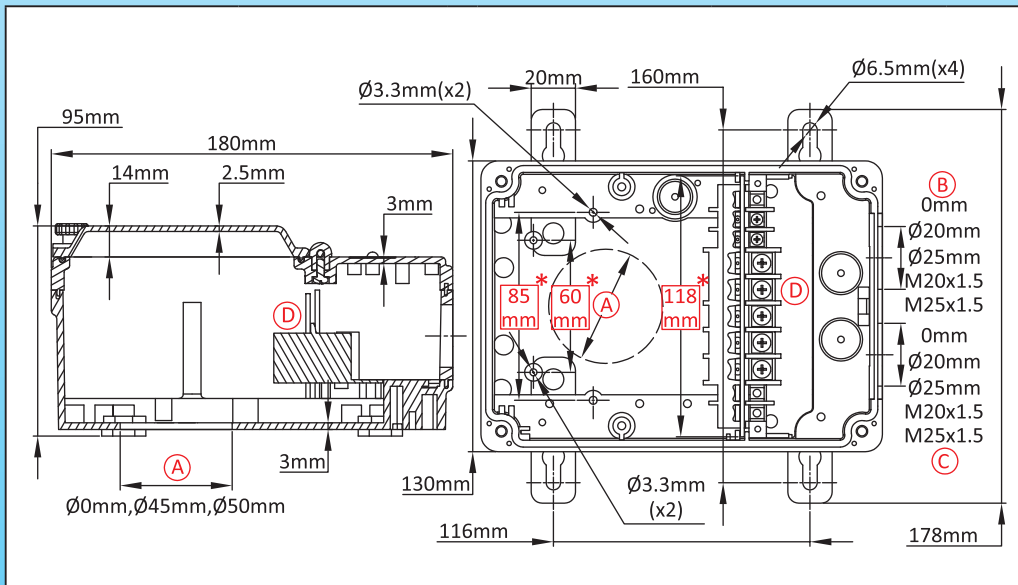

### Main references

Ⓐ(mm)	Ⓑ(mm)	Ⓒ(mm)	With connection block Ⓓ	Without connection block Ⓓ	Ⓐ(mm)	Ⓑ(mm)	Ⓒ(mm)	With connection block Ⓓ	Without connection block Ⓓ
0	0	0	Y3N2000000J100T	Y3N200000000000T	45	20	20	Y3N24500220J100T	Y3N245002200000T
0	0	20	Y3N20000120J100T	Y3N200001200000T	45	25	25	Y3N24500225J100T	Y3N245002250000T
0	0	25	Y3N20000125J100T	Y3N200001250000T	45	M20x1.5	M20x1.5	Y3N245002T0J100T	Y3N245002T00000T
0	0	M20x1.5	Y3N200001T0J100T	Y3N200001T00000T	45	M25x1.5	M25x1.5	Y3N245002T5J100T	Y3N245002T50000T
0	0	M25x1.5	Y3N200001T5J100T	Y3N200001T50000T	50	0	0	Y3N2500000J100T	Y3N250000000000T
0	20	20	Y3N20000220J100T	Y3N200002200000T	50	0	20	Y3N25000120J100T	Y3N250001200000T
0	25	25	Y3N20000225J100T	Y3N200002250000T	50	0	25	Y3N25000125J100T	Y3N250001250000T
0	M20x1.5	M20x1.5	Y3N200002T0J100T	Y3N200002T00000T	50	0	M20x1.5	Y3N250001T0J100T	Y3N250001T00000T
0	M25x1.5	M25x1.5	Y3N200002T5J100T	Y3N200002T50000T	50	0	M25x1.5	Y3N250001T5J100T	Y3N250001T50000T
45	0	0	Y3N24500000J100T	Y3N245000000000T	50	20	20	Y3N25000220J100T	Y3N250002200000T
45	0	20	Y3N24500120J100T	Y3N245001200000T	50	25	25	Y3N25000225J100T	Y3N250002250000T
45	0	25	Y3N24500125J100T	Y3N245001250000T	50	M20x1.5	M20x1.5	Y3N250002T0J100T	Y3N250002T00000T
45	0	M20x1.5	Y3N245001T0J100T	Y3N245001T00000T	50	M25x1.5	M25x1.5	Y3N250002T5J100T	Y3N250002T50000T
45	0	M25x1.5	Y3N245001T5J100T	Y3N245001T50000T					

Cable gland not included in these reference, consult us if you want them.

Red dimensions inside rectangular frames on drawings are used for accessories assembly.

# Enclosure with window for immersion heaters, with extension. Body in PA66

Size(mm)	Volume(cm <sup>3</sup> )	Material	Protection grade		Model
130 X 180 X 120	2093	PA66 + PC	IP69K	IK10	<b>Y3N3</b>

Suitable for
<input type="checkbox"/> Temperature sensor
<input checked="" type="checkbox"/> Immersion heater
<input checked="" type="checkbox"/> Finned heater
<input checked="" type="checkbox"/> Thermostat
<input type="checkbox"/> Level sensor
<input checked="" type="checkbox"/> Electronic board

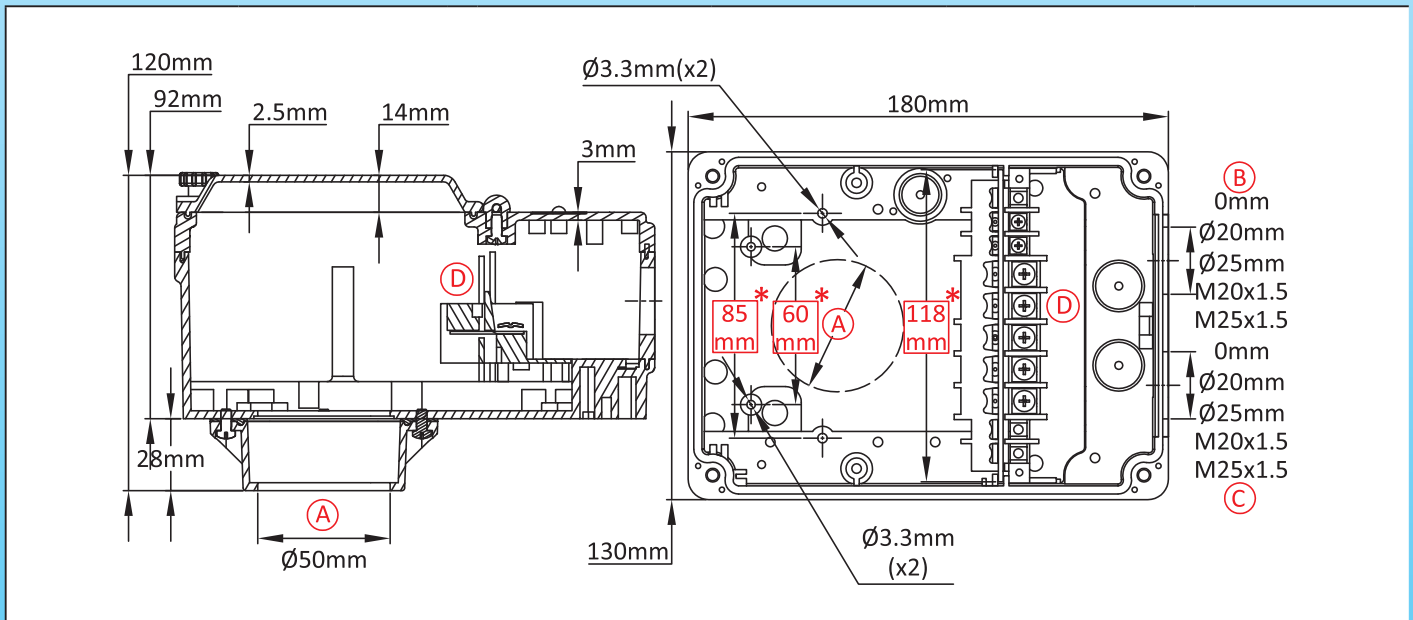
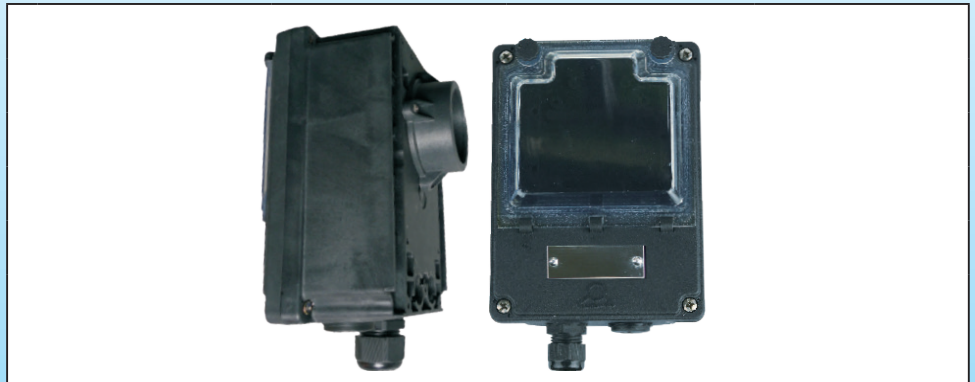

## Main references

ⓑ(mm)	ⓒ(mm)	With connection block ⓓ	Without connection block ⓓ
0	0	Y3N35000000J100T	Y3N350000000000T
0	20	Y3N35000120J100T	Y3N350001200000T
0	25	Y3N35000125J100T	Y3N350001250000T
0	M20x1.5	Y3N350001T0J100T	Y3N350001T00000T
0	M25x1.5	Y3N350001T5J100T	Y3N350001T50000T
20	20	Y3N35000220J100T	Y3N350002200000T
25	25	Y3N35000225J100T	Y3N350002250000T
M20x1.5	M20x1.5	Y3N350002T0J100T	Y3N350002T00000T
M25x1.5	M25x1.5	Y3N350002T5J100T	Y3N350002T50000T

## Links



Page (.pdf)



Drawing 2D (.dwg)



Drawing 3D (.stp)

Cable gland not included in these reference, consult us if you want them.

Red dimensions inside rectangular frames on drawings are used for accessories assembly.

# Enclosure with window, for immersion heater with electronic temperature control with aluminum heat exchanger fins for solid state relay. PA66 + PC + Aluminum

Size(mm)	Volume(cm <sup>3</sup> )	Material	Protection grade		Model
<b>130 X 180 X 132</b>	<b>2580</b>	<b>PA66 + PC + Aluminum</b>	<b>IP69K</b>	<b>IK10</b>	<b>Y3N4</b>

### Suitable for

- Temperature sensor
- Immersion heater
- Finned heater
- Thermostat
- Level sensor
- Electronic board

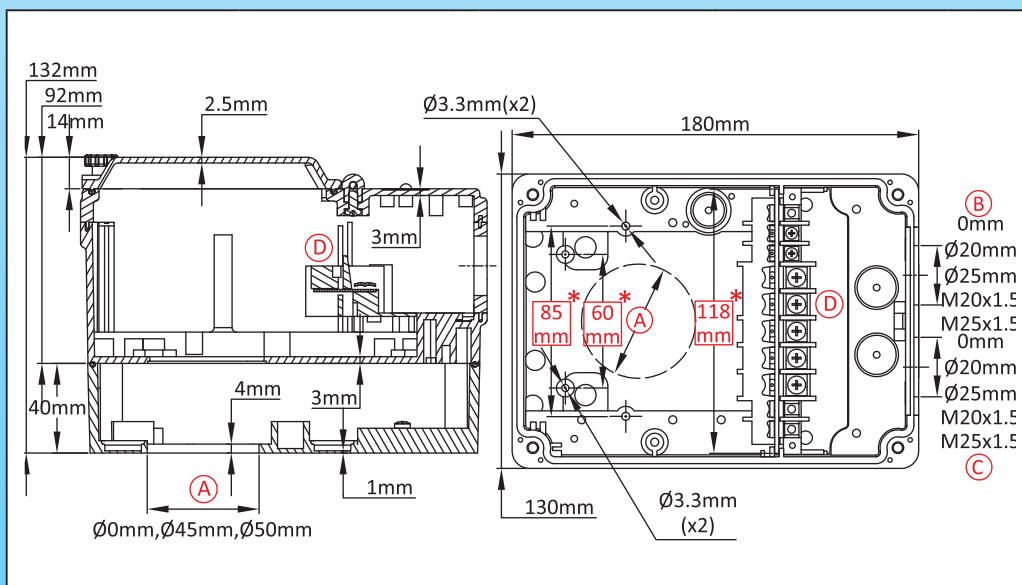
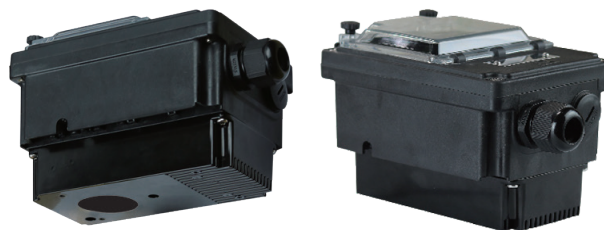

### Links



Page  
(.pdf)



Drawing 2D  
(.dwg)



Drawing 3D  
(.stp)

### Main references

Ⓐ(mm)	Ⓑ(mm)	Ⓒ(mm)	With connection block Ⓓ	Without connection block Ⓓ	Ⓐ(mm)	Ⓑ(mm)	Ⓒ(mm)	With connection block Ⓔ	Without connection block Ⓔ
0	0	0	Y3N4000000J100T	Y3N400000000000T	45	20	20	Y3N44500220J100T	Y3N445002200000T
0	0	20	Y3N40000120J100T	Y3N400001200000T	45	25	25	Y3N44500225J100T	Y3N445002250000T
0	0	25	Y3N40000125J100T	Y3N400001250000T	45	M20x1.5	M20x1.5	Y3N445002T0J100T	Y3N445002T00000T
0	0	M20x1.5	Y3N400001T0J100T	Y3N400001T00000T	45	M25x1.5	M25x1.5	Y3N445002T5J100T	Y3N445002T50000T
0	0	M25x1.5	Y3N400001T5J100T	Y3N400001T50000T	50	0	0	Y3N45000000J100T	Y3N450000000000T
0	20	20	Y3N40000220J100T	Y3N400002200000T	50	0	20	Y3N45000120J100T	Y3N450001200000T
0	25	25	Y3N40000225J100T	Y3N400002250000T	50	0	25	Y3N45000125J100T	Y3N450001250000T
0	M20x1.5	M20x1.5	Y3N400002T0J100T	Y3N400002T00000T	50	0	M20x1.5	Y3N450001T0J100T	Y3N450001T00000T
0	M25x1.5	M25x1.5	Y3N400002T5J100T	Y3N400002T50000T	50	0	M25x1.5	Y3N450001T5J100T	Y3N450001T50000T
45	0	0	Y3N44500000J100T	Y3N445000000000T	50	20	20	Y3N45000220J100T	Y3N450002200000T
45	0	20	Y3N445000120J100T	Y3N4450001200000T	50	25	25	Y3N45000225J100T	Y3N450002250000T
45	0	25	Y3N445000125J100T	Y3N4450001250000T	50	M20x1.5	M20x1.5	Y3N450002T0J100T	Y3N450002T00000T
45	0	M20x1.5	Y3N4450001T0J100T	Y3N4450001T00000T	50	M25x1.5	M25x1.5	Y3N450002T5J100T	Y3N450002T50000T
45	0	M25x1.5	Y3N4450001T5J100T	Y3N4450001T50000T					

Cable gland not included in these reference, consult us if you want them.

Red dimensions inside rectangular frames on drawings are used for accessories assembly.

# Polypropylene immersion heater enclosure for surface treatment baths and highly corrosive environments

Size(mm)	Volume(cm <sup>3</sup> )	Material	Protection grade		Model
Dia. 105 x 95	663	Polypropylène	IP69K	IK10	<b>Y3C6</b>

Suitable for
<input type="checkbox"/> Temperature sensor
<input checked="" type="checkbox"/> Immersion heater
<input type="checkbox"/> Finned heater
<input checked="" type="checkbox"/> Thermostat
<input type="checkbox"/> Level sensor
<input type="checkbox"/> Electronic board

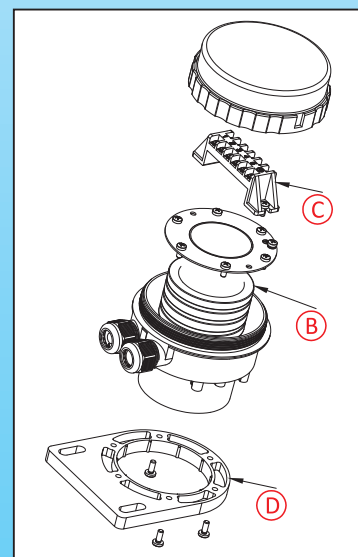
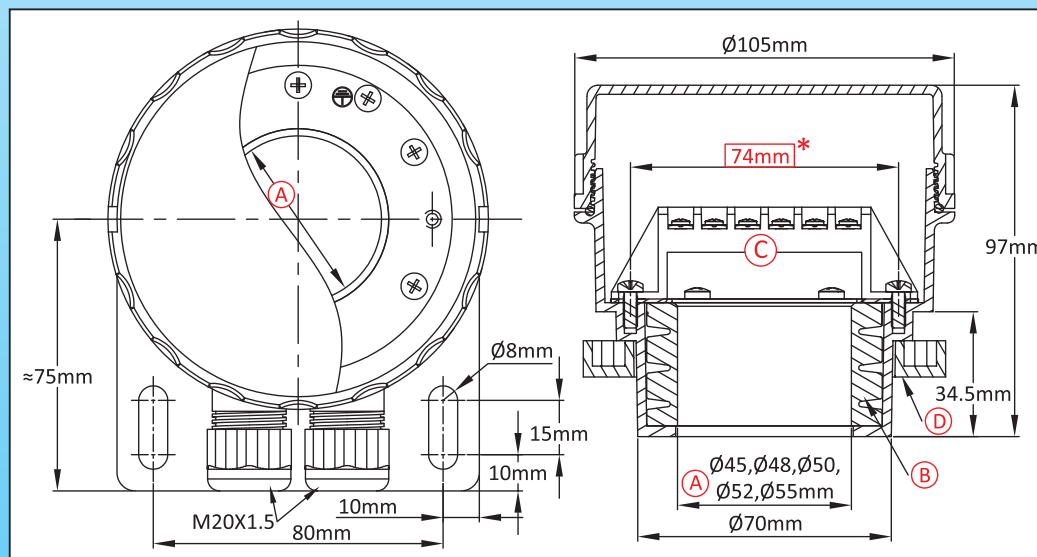
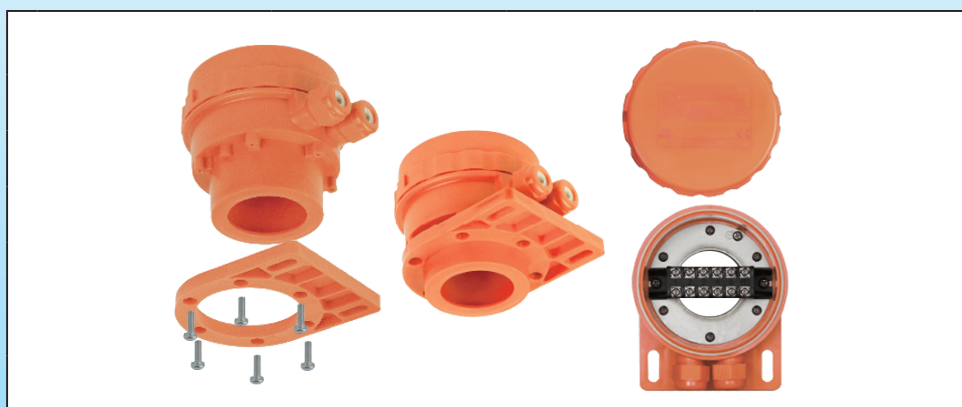

## Main references

Ⓐ(mm)	Ⓑ	Ⓓ	With connection block Ⓒ	Without connection block Ⓒ	Ⓐ(mm)	Ⓑ	Ⓓ	With connection block Ⓒ	Without connection block Ⓒ
45	Silicone	✓	Y3C6450022BH40XU	Y3C6450022B000XU	50	FKM	×	Y3C6500022BH40WU	Y3C6500022B000WU
45	Silicone	×	Y3C6450022BH40UU	Y3C6450022B000UU	50	NBR	✓	Y3C6500022BH40YU	Y3C6500022B000YU
45	FKM	✓	Y3C6450022BH40ZU	Y3C6450022B000ZU	50	NBR	×	Y3C6500022BH40VU	Y3C6500022B000VU
45	FKM	×	Y3C6450022BH40WU	Y3C6450022B000WU	52	Silicone	✓	Y3C6520022BH40XU	Y3C6520022B000XU
45	NBR	✓	Y3C6450022BH40YU	Y3C6450022B000YU	52	Silicone	×	Y3C6520022BH40UU	Y3C6520022B000UU
45	NBR	×	Y3C6450022BH40VU	Y3C6450022B000VU	52	FKM	✓	Y3C6520022BH40ZU	Y3C6520022B000ZU
48	Silicone	✓	Y3C6480022BH40XU	Y3C6480022B000XU	52	FKM	×	Y3C6520022BH40WU	Y3C6520022B000WU
48	Silicone	×	Y3C6480022BH40UU	Y3C6480022B000UU	52	NBR	✓	Y3C6520022BH40YU	Y3C6520022B000YU
48	FKM	✓	Y3C6480022BH40ZU	Y3C6480022B000ZU	52	NBR	×	Y3C6520022BH40VU	Y3C6520022B000VU
48	FKM	×	Y3C6480022BH40WU	Y3C6480022B000WU	55	Silicone	✓	Y3C6550022BH40XU	Y3C6550022B000XU
48	NBR	✓	Y3C6480022BH40YU	Y3C6480022B000YU	55	Silicone	×	Y3C6550022BH40UU	Y3C6550022B000UU
48	NBR	×	Y3C6480022BH40VU	Y3C6480022B000VU	55	FKM	✓	Y3C6550022BH40ZU	Y3C6550022B000ZU
50	Silicone	✓	Y3C6500022BH40XU	Y3C6500022B000XU	55	FKM	×	Y3C6550022BH40WU	Y3C6550022B000WU
50	Silicone	×	Y3C6500022BH40UU	Y3C6500022B000UU	55	NBR	✓	Y3C6550022BH40YU	Y3C6550022B000YU
50	FKM	✓	Y3C6500022BH40ZU	Y3C6500022B000ZU	55	NBR	×	Y3C6550022BH40VU	Y3C6550022B000VU

## Links

	Page (.pdf)		Drawing 2D (.dwg)		Drawing 3D (.stp)
--	-------------	--	-------------------	--	-------------------

Cable gland not included in these reference, consult us if you want them.

Red dimensions inside rectangular frames on drawings are used for accessories assembly.

# Polypropylene immersion heater enclosure for surface treatment baths and highly corrosive, environments

Size(mm)	Volume(cm <sup>3</sup> )	Material	Protection grade		Model
Dia. 105 x 95	663	Polypropylène	IP69K	IK10	<b>Y3C7</b>

Suitable for
<input type="checkbox"/> Temperature sensor
<input checked="" type="checkbox"/> Immersion heater
<input type="checkbox"/> Finned heater
<input checked="" type="checkbox"/> Thermostat
<input type="checkbox"/> Level sensor
<input type="checkbox"/> Electronic board

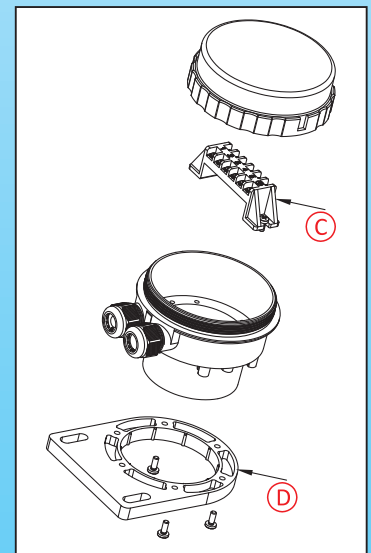
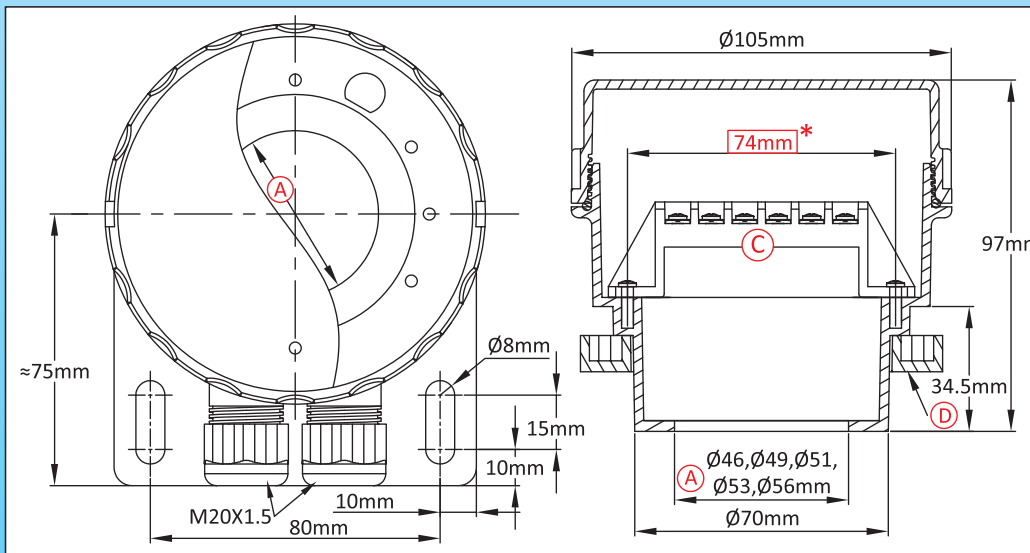
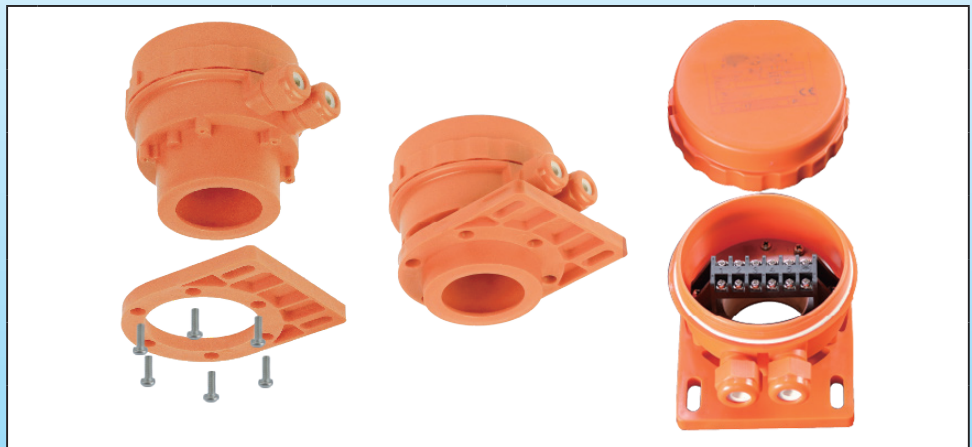

## Main references

Ⓐ (mm)	Ⓑ	With connection block Ⓒ	Without connection block Ⓒ
46	✓	Y3C7460022BH40TU	Y3C7460022B000TU
46	✗	Y3C7460022BH400U	Y3C7460022B0000U
49	✓	Y3C7490022BH40TU	Y3C7490022B000TU
49	✗	Y3C7490022BH400U	Y3C7490022B0000U
51	✓	Y3C7510022BH40TU	Y3C7510022B000TU
51	✗	Y3C7510022BH400U	Y3C7510022B0000U
53	✓	Y3C7530022BH40TU	Y3C7530022B000TU
53	✗	Y3C7530022BH400U	Y3C7530022B0000U
56	✓	Y3C7560022BH40TU	Y3C7560022B000TU
56	✗	Y3C7560022BH400U	Y3C7560022B0000U

## Links



Page  
(.pdf)



Drawing 2D  
(.dwg)



Drawing 3D  
(.stp)

Because of permanent improvement of our products, drawings, descriptions, features used on these data sheets are for guidance only and can be modified without prior advice

Cable gland not included in these reference, consult us if you want them.

Red dimensions inside rectangular frames on drawings are used for accessories assembly.

# Polypropylene temperature sensor enclosure for surface treatment baths and highly corrosive environments

Size(mm)	Volume(cm <sup>3</sup> )	Material	Protection grade		Model
Dia. 105 x 82	525	Polypropylène	IP69K	IK10	<b>Y3C8</b>

Suitable for
<input checked="" type="checkbox"/> Temperature sensor
<input type="checkbox"/> Immersion heater
<input type="checkbox"/> Finned heater
<input checked="" type="checkbox"/> Thermostat
<input checked="" type="checkbox"/> Level sensor
<input type="checkbox"/> Electronic board

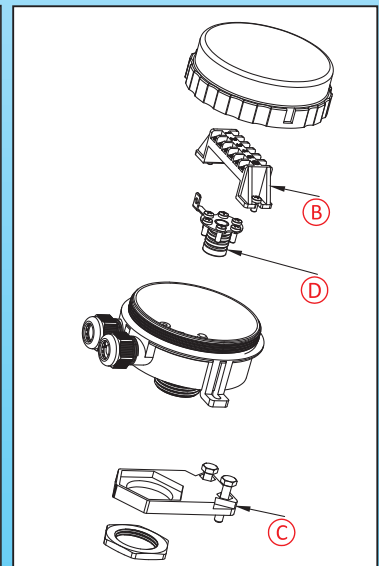
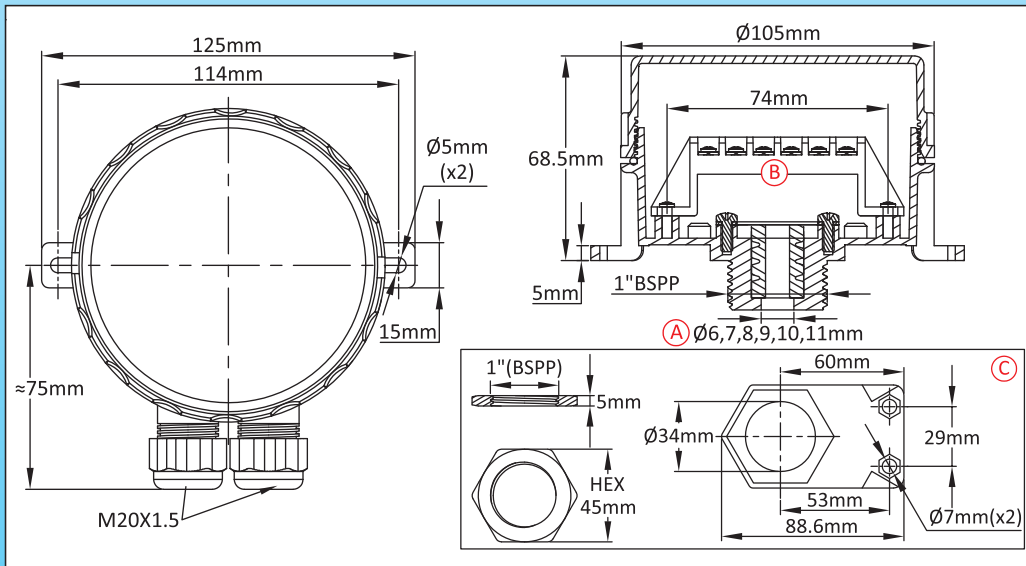
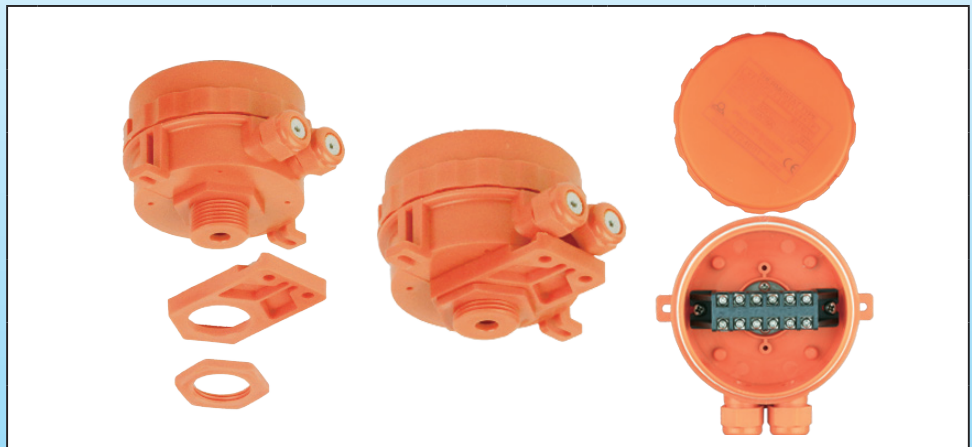

## Main references

(A) (mm)	(D)	(C)	With connection block (B)	Without connection block (B)	(A) (mm)	(D)	(C)	With connection block (B)	Without connection block (B)
6	Silicone	√	Y3C8060022BH40XU	Y3C8060022B000XU	9	Silicone	√	Y3C8090022BH40XU	Y3C8090022B000XU
6	Silicone	×	Y3C8060022BH40UU	Y3C8060022B000UU	9	Silicone	×	Y3C8090022BH40UU	Y3C8090022B000UU
6	FKM	√	Y3C8060022BH40ZU	Y3C8060022B000ZU	9	FKM	√	Y3C8090022BH40ZU	Y3C8090022B000ZU
6	FKM	×	Y3C8060022BH40WU	Y3C8060022B000WU	9	FKM	×	Y3C8090022BH40WU	Y3C8090022B000WU
6	NBR	√	Y3C8060022BH40YU	Y3C8060022B000YU	9	NBR	√	Y3C8090022BH40YU	Y3C8090022B000YU
6	NBR	×	Y3C8060022BH40VU	Y3C8060022B000VU	9	NBR	×	Y3C8090022BH40VU	Y3C8090022B000VU
7	Silicone	√	Y3C8070022BH40XU	Y3C8070022B000XU	10	Silicone	√	Y3C8100022BH40XU	Y3C8100022B000XU
7	Silicone	×	Y3C8070022BH40UU	Y3C8070022B000UU	10	Silicone	×	Y3C8100022BH40UU	Y3C8100022B000UU
7	FKM	√	Y3C8070022BH40ZU	Y3C8070022B000ZU	10	FKM	√	Y3C8100022BH40ZU	Y3C8100022B000ZU
7	FKM	×	Y3C8070022BH40WU	Y3C8070022B000WU	10	FKM	×	Y3C8100022BH40WU	Y3C8100022B000WU
7	NBR	√	Y3C8070022BH40YU	Y3C8070022B000YU	10	NBR	√	Y3C8100022BH40YU	Y3C8100022B000YU
7	NBR	×	Y3C8070022BH40VU	Y3C8070022B000VU	10	NBR	×	Y3C8100022BH40VU	Y3C8100022B000VU
8	Silicone	√	Y3C8080022BH40XU	Y3C8080022B000XU	11	Silicone	√	Y3C8110022BH40XU	Y3C8110022B000XU
8	Silicone	×	Y3C8080022BH40UU	Y3C8080022B000UU	11	Silicone	×	Y3C8110022BH40UU	Y3C8110022B000UU
8	FKM	√	Y3C8080022BH40ZU	Y3C8080022B000ZU	11	FKM	√	Y3C8110022BH40ZU	Y3C8110022B000ZU
8	FKM	×	Y3C8080022BH40WU	Y3C8080022B000WU	11	FKM	×	Y3C8110022BH40WU	Y3C8110022B000WU
8	NBR	√	Y3C8080022BH40YU	Y3C8080022B000YU	11	NBR	√	Y3C8110022BH40YU	Y3C8110022B000YU
8	NBR	×	Y3C8080022BH40VU	Y3C8080022B000VU	11	NBR	×	Y3C8110022BH40VU	Y3C8110022B000VU

## Links

Page  
(.pdf)

Drawing  
2D  
(.dwg)

Drawing  
3D  
(.stp)

Cable gland not included in these reference, consult us if you want them.

Red dimensions inside rectangular frames on drawings are used for accessories assembly.



# PVDF immersion heater enclosure for surface treatment baths and highly corrosive environments

Size(mm)	Volume(cm <sup>3</sup> )	Material	Protection grade		Model
<b>Dia. 105 x 95</b>	<b>663</b>	<b>PVDF</b>	<b>IP69K</b>	<b>IK10</b>	<b>Y3E6</b>

Suitable for
<input type="checkbox"/> Temperature sensor
<input checked="" type="checkbox"/> Immersion heater
<input type="checkbox"/> Finned heater
<input checked="" type="checkbox"/> Thermostat
<input type="checkbox"/> Level sensor
<input type="checkbox"/> Electronic board

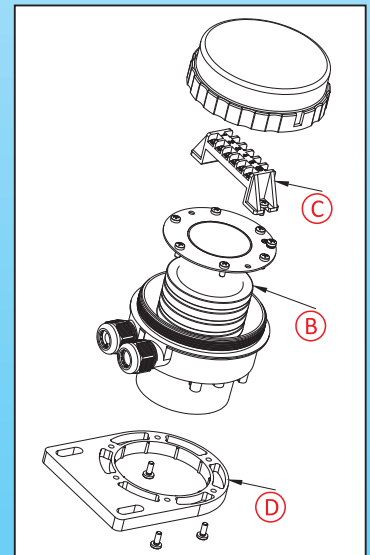
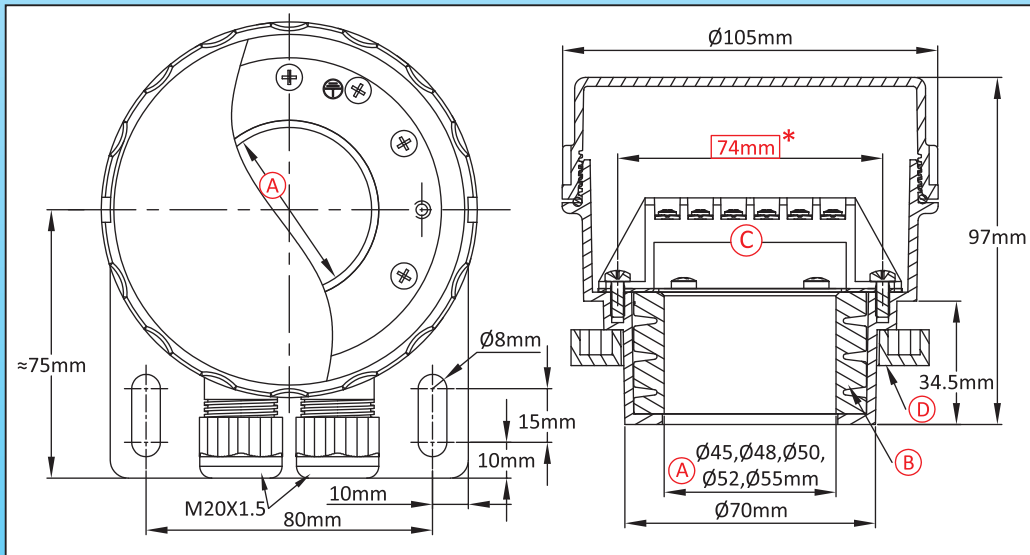
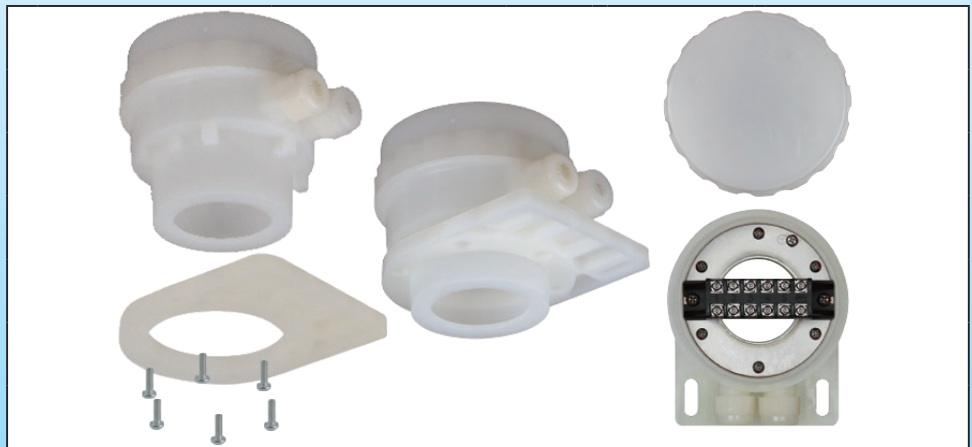

(A)(mm)	(B)	(D)	With connection block (C)	Without connection block (C)	(A)(mm)	(B)	(D)	With connection block (C)	Without connection block (C)
45	Silicone	✓	Y3E6450022BH40XT	Y3E6450022B000XT	50	FKM	×	Y3E6500022BH40WT	Y3E6500022B000WT
45	Silicone	×	Y3E6450022BH40UT	Y3E6450022B000UT	50	NBR	✓	Y3E6500022BH40YT	Y3E6500022B000YT
45	FKM	✓	Y3E6450022BH40ZT	Y3E6450022B000ZT	50	NBR	×	Y3E6500022BH40VT	Y3E6500022B000VT
45	FKM	×	Y3E6450022BH40WT	Y3E6450022B000WT	52	Silicone	✓	Y3E6520022BH40XT	Y3E6520022B000XT
45	NBR	✓	Y3E6450022BH40YT	Y3E6450022B000YT	52	Silicone	×	Y3E6520022BH40UT	Y3E6520022B000UT
45	NBR	×	Y3E6450022BH40VT	Y3E6450022B000VT	52	FKM	✓	Y3E6520022BH40ZT	Y3E6520022B000ZT
48	Silicone	✓	Y3E6480022BH40XT	Y3E6480022B000XT	52	FKM	×	Y3E6520022BH40WT	Y3E6520022B000WT
48	Silicone	×	Y3E6480022BH40UT	Y3E6480022B000UT	52	NBR	✓	Y3E6520022BH40YT	Y3E6520022B000YT
48	FKM	✓	Y3E6480022BH40ZT	Y3E6480022B000ZT	52	NBR	×	Y3E6520022BH40VT	Y3E6520022B000VT
48	FKM	×	Y3E6480022BH40WT	Y3E6480022B000WT	55	Silicone	✓	Y3E6550022BH40XT	Y3E6550022B000XT
48	NBR	✓	Y3E6480022BH40YT	Y3E6480022B000YT	55	Silicone	×	Y3E6550022BH40UT	Y3E6550022B000UT
48	NBR	×	Y3E6480022BH40VT	Y3E6480022B000VT	55	FKM	✓	Y3E6550022BH40ZT	Y3E6550022B000ZT
50	Silicone	✓	Y3E6500022BH40XT	Y3E6500022B000XT	55	FKM	×	Y3E6550022BH40WT	Y3E6550022B000WT
50	Silicone	×	Y3E6500022BH40UT	Y3E6500022B000UT	55	NBR	✓	Y3E6550022BH40YT	Y3E6550022B000YT
50	FKM	✓	Y3E6500022BH40ZT	Y3E6500022B000ZT	55	NBR	×	Y3E6550022BH40VT	Y3E6550022B000VT

## Links

<p>Page (.pdf)</p>	<p>Drawing 2D (.dwg)</p>	<p>Drawing 3D (.stp)</p>
------------------------	------------------------------	------------------------------

Cable gland not included in these reference, consult us if you want them.

Red dimensions inside rectangular frames on drawings are used for accessories assembly.

Because of permanent improvement of our products, drawings, descriptions, features used on these data sheets are for guidance only and can be modified without prior advice

# PVDF immersion heater enclosure for surface treatment baths and highly corrosive environments

Size(mm)	Volume(cm <sup>3</sup> )	Material	Protection grade		Model
Dia. 105 x 95	663	PVDF	IP69K	IK10	<b>Y3E7</b>

Suitable for
<input type="checkbox"/> Temperature sensor
<input checked="" type="checkbox"/> Immersion heater
<input type="checkbox"/> Finned heater
<input checked="" type="checkbox"/> Thermostat
<input type="checkbox"/> Level sensor
<input type="checkbox"/> Electronic board

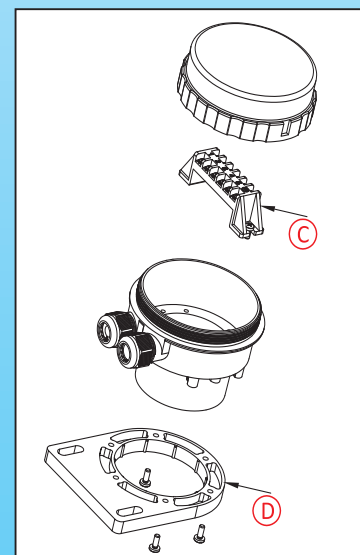
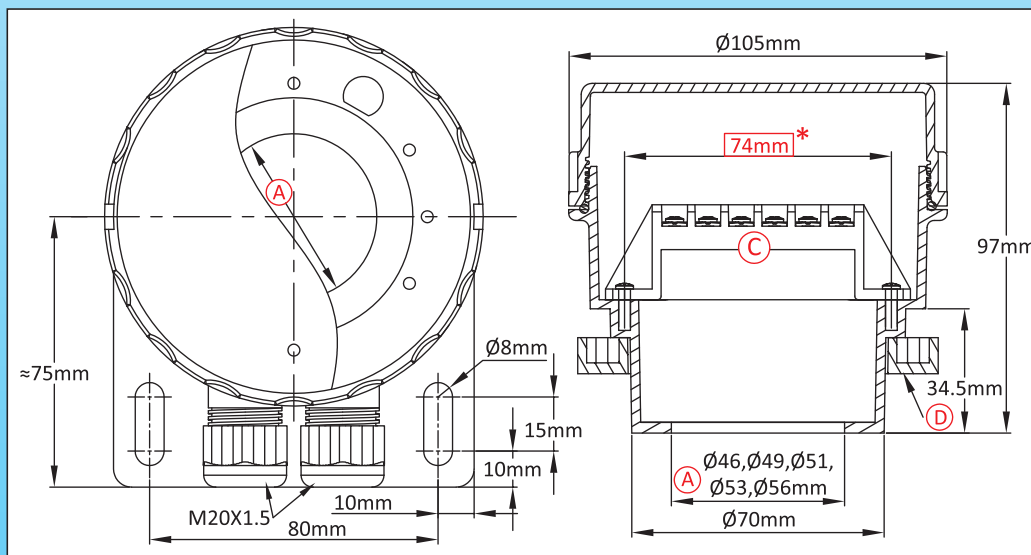

### Main references

Ⓐ (mm)	Ⓑ	With connection block Ⓒ	Without connection block Ⓒ
46	✓	Y3E7460022BH40TT	Y3E7460022B000TT
46	×	Y3E7460022BH400T	Y3E7460022B0000T
49	✓	Y3E7490022BH40TT	Y3E7490022B000TT
49	×	Y3E7490022BH400T	Y3E7490022B0000T
51	✓	Y3E7510022BH40TT	Y3E7510022B000TT
51	×	Y3E7510022BH400T	Y3E7510022B0000T
53	✓	Y3E7530022BH40TT	Y3E7530022B000TT
53	×	Y3E7530022BH400T	Y3E7530022B0000T
56	✓	Y3E7560022BH40TT	Y3E7560022B000TT
56	×	Y3E7560022BH400T	Y3E7560022B0000T

### Links

Page  
(.pdf)

Drawing 2D  
(.dwg)

Drawing 3D  
(.stp)

Cable gland not included in these reference, consult us if you want them.

Red dimensions inside rectangular frames on drawings are used for accessories assembly.

# PVDF temperature sensor enclosure for surface treatment baths and highly corrosive environments

Size(mm)	Volume(cm <sup>3</sup> )	Material	Protection grade		Model
<b>Dia. 105 x 82</b>	<b>525</b>	<b>PVDF</b>	<b>IP69K</b>	<b>IK10</b>	<b>Y3E8</b>

Suitable for
<input checked="" type="checkbox"/> Temperature sensor
<input type="checkbox"/> Immersion heater
<input type="checkbox"/> Finned heater
<input checked="" type="checkbox"/> Thermostat
<input checked="" type="checkbox"/> Level sensor
<input type="checkbox"/> Electronic board

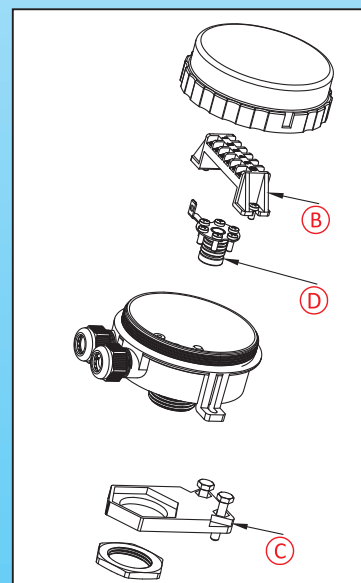
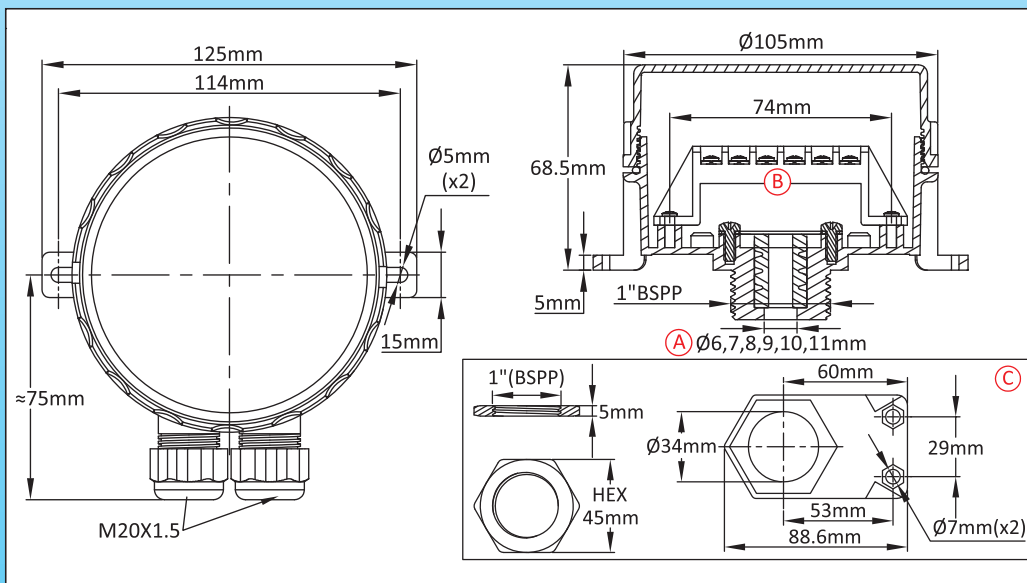
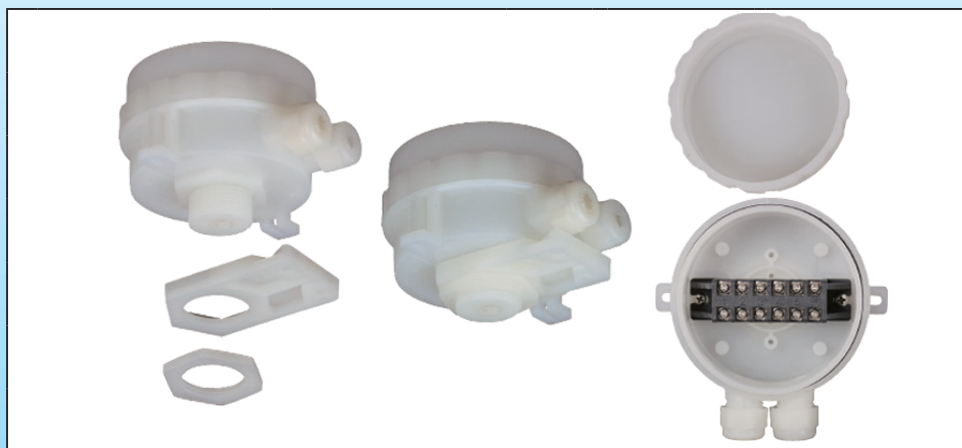

### Main references

(A) (mm)	(D)	(C)	With connection block (B)	Without connection block (B)	(A) (mm)	(D)	(C)	With connection block (B)	Without connection block (B)
6	Silicone	√	Y3E8060022BH40XT	Y3E8060022B000XT	9	Silicone	√	Y3E8090022BH40XT	Y3E8090022B000XT
6	Silicone	×	Y3E8060022BH40UT	Y3E8060022B000UT	9	Silicone	×	Y3E8090022BH40UT	Y3E8090022B000UT
6	FKM	√	Y3E8060022BH40ZT	Y3E8060022B000ZT	9	FKM	√	Y3E8090022BH40ZT	Y3E8090022B000ZT
6	FKM	×	Y3E8060022BH40WT	Y3E8060022B000WT	9	FKM	×	Y3E8090022BH40WT	Y3E8090022B000WT
6	NBR	√	Y3E8060022BH40YT	Y3E8060022B000YT	9	NBR	√	Y3E8090022BH40YT	Y3E8090022B000YT
6	NBR	×	Y3E8060022BH40VT	Y3E8060022B000VT	9	NBR	×	Y3E8090022BH40VT	Y3E8090022B000VT
7	Silicone	√	Y3E8070022BH40XT	Y3E8070022B000XT	10	Silicone	√	Y3E8100022BH40XT	Y3E8100022B000XT
7	Silicone	×	Y3E8070022BH40UT	Y3E8070022B000UT	10	Silicone	×	Y3E8100022BH40UT	Y3E8100022B000UT
7	FKM	√	Y3E8070022BH40ZT	Y3E8070022B000ZT	10	FKM	√	Y3E8100022BH40ZT	Y3E8100022B000ZT
7	FKM	×	Y3E8070022BH40WT	Y3E8070022B000WT	10	FKM	×	Y3E8100022BH40WT	Y3E8100022B000WT
7	NBR	√	Y3E8070022BH40YT	Y3E8070022B000YT	10	NBR	√	Y3E8100022BH40YT	Y3E8100022B000YT
7	NBR	×	Y3E8070022BH40VT	Y3E8070022B000VT	10	NBR	×	Y3E8100022BH40VT	Y3E8100022B000VT
8	Silicone	√	Y3E8080022BH40XT	Y3E8080022B000XT	11	Silicone	√	Y3E8110022BH40XT	Y3E8110022B000XT
8	Silicone	×	Y3E8080022BH40UT	Y3E8080022B000UT	11	Silicone	×	Y3E8110022BH40UT	Y3E8110022B000UT
8	FKM	√	Y3E8080022BH40ZT	Y3E8080022B000ZT	11	FKM	√	Y3E8110022BH40ZT	Y3E8110022B000ZT
8	FKM	×	Y3E8080022BH40WT	Y3E8080022B000WT	11	FKM	×	Y3E8110022BH40WT	Y3E8110022B000WT
8	NBR	√	Y3E8080022BH40YT	Y3E8080022B000YT	11	NBR	√	Y3E8110022BH40YT	Y3E8110022B000YT
8	NBR	×	Y3E8080022BH40VT	Y3E8080022B000VT	11	NBR	×	Y3E8110022BH40VT	Y3E8110022B000VT

### Links

Page  
(.pdf)

Drawing  
2D  
(.dwg)

Drawing  
3D  
(.stp)

Cable gland not included in these reference, consult us if you want them.

Red dimensions inside rectangular frames on drawings are used for accessories assembly.

Because of permanent improvement of our products, drawings, descriptions, features used on these data sheets are for guidance only and can be modified without prior advice





# Aluminum enclosures

**The references given in these documents are the most common. The dotted areas in the plans indicate the options.**

These enclosures are in pressure die cast aluminum. Depending of models, covers can be in aluminum, polycarbonate or fiberglass reinforced PA 6.6.

In standard, screws and fasteners are stainless steel.

In standard, gaskets are in silicone. They can be supplied in NBR or FKM (Viton) on request.

**Red dimensions inside rectangular frames on drawings are used for accessories assembly.**

For more information consult our technical service.



# Miniature enclosure for immersion heater, level sensor or temperature sensor

Size(mm)	Volume(cm <sup>3</sup> )	Material	Protection grade		Model
<b>78 x 66 x 50</b>	<b>210</b>	<b>Aluminum</b>	<b>IP69K</b>	<b>IK10</b>	<b>Y303</b> <b>(P1)</b>

### Suitable for

- Temperature sensor
- Immersion heater
- Finned heater
- Thermostat
- Level sensor
- Electronic board

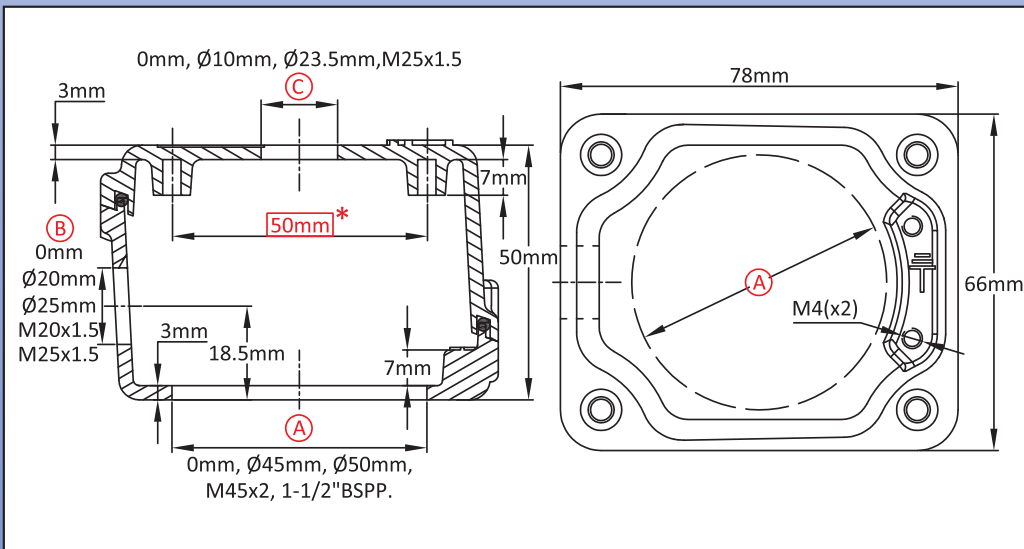

### Links



Page  
(.pdf)



Drawing 2D  
(.dwg)



Drawing 3D  
(.stp)

### Main references

(A) (mm)	(B) (mm)	(C) (mm)	Not painted	Painted	(A) (mm)	(B) (mm)	(C) (mm)	Not painted	Painted
0	0	0	Y303000000000007	Y30300000000000G	0	M20x1.5	0	Y30300001T000007	Y30300001T00000G
0	0	10	Y303000A00000007	Y303000A0000000G	0	M20x1.5	10	Y303000A1T000007	Y303000A1T00000G
0	0	23.5	Y303000D00000007	Y303000D0000000G	0	M20x1.5	23.5	Y303000D1T000007	Y303000D1T00000G
0	0	M25x1.5	Y303000F00000007	Y303000F0000000G	0	M20x1.5	M25x1.5	Y303000F1T000007	Y303000F1T00000G
0	20	0	Y303000012000007	Y30300001200000G	0	M25x1.5	0	Y30300001T500007	Y30300001T50000G
0	20	10	Y303000A12000007	Y303000A1200000G	0	M25x1.5	10	Y303000A1T500007	Y303000A1T50000G
0	20	23.5	Y303000D12000007	Y303000D1200000G	0	M25x1.5	23.5	Y303000D1T500007	Y303000D1T50000G
0	20	M25x1.5	Y303000F12000007	Y303000F1200000G	0	M25x1.5	M25x1.5	Y303000F1T500007	Y303000F1T50000G
0	25	0	Y303000012500007	Y30300001250000G	45	0	0	Y303450000000007	Y30345000000000G
0	25	10	Y303000A12500007	Y303000A1250000G	45	0	10	Y303450A00000007	Y303450A00000000G
0	25	23.5	Y303000D12500007	Y303000D1250000G	45	0	23.5	Y303450D00000007	Y303450D00000000G
0	25	M25x1.5	Y303000F12500007	Y303000F1250000G	45	0	M25x1.5	Y303450F00000007	Y303450F00000000G

Cable gland not included in these reference, consult us if you want them.

Red dimensions inside rectangular frames are used for accessories assembly.

Because of permanent improvement of our products, drawings, descriptions, features used on these data sheets are for guidance only and can be modified without prior advice

# Miniature enclosure for immersion heater, level sensor or temperature sensor

**Y303  
(P2)**

(A) (mm)	(B) (mm)	(C) (mm)	Not painted	Painted	(A) (mm)	(B) (mm)	(C) (mm)	Not painted	Painted
45	20	0	Y303450012000007	Y30345001200000G	M45x2	0	23.5	Y303M45D000000007	Y303M45D00000000G
45	20	10	Y303450A12000007	Y303450A1200000G	M45x2	0	M25x1.5	Y303M45F000000007	Y303M45F00000000G
45	20	23.5	Y303450D12000007	Y303450D1200000G	M45x2	20	0	Y303M45012000007	Y303M4501200000G
45	20	M25x1.5	Y303450F12000007	Y303450F1200000G	M45x2	20	10	Y303M45A12000007	Y303M45A1200000G
45	25	0	Y303450012500007	Y30345001250000G	M45x2	20	23.5	Y303M45D12000007	Y303M45D1200000G
45	25	10	Y303450A12500007	Y303450A1250000G	M45x2	20	M25x1.5	Y303M45F12000007	Y303M45F1200000G
45	25	23.5	Y303450D12500007	Y303450D1250000G	M45x2	25	0	Y303M45012500007	Y303M4501250000G
45	25	M25x1.5	Y303450F12500007	Y303450F1250000G	M45x2	25	10	Y303M45A12500007	Y303M45A1250000G
45	M20x1.5	0	Y30345001T000007	Y30345001T00000G	M45x2	25	23.5	Y303M45D12500007	Y303M45D1250000G
45	M20x1.5	10	Y303450A1T000007	Y303450A1T00000G	M45x2	25	M25x1.5	Y303M45F12500007	Y303M45F1250000G
45	M20x1.5	23.5	Y303450D1T000007	Y303450D1T00000G	M45x2	M20x1.5	0	Y303M4501T000007	Y303M4501T00000G
45	M20x1.5	M25x1.5	Y303450F1T000007	Y303450F1T00000G	M45x2	M20x1.5	10	Y303M45A1T000007	Y303M45A1T00000G
45	M25x1.5	0	Y30345001T500007	Y30345001T50000G	M45x2	M20x1.5	23.5	Y303M45D1T000007	Y303M45D1T00000G
45	M25x1.5	10	Y303450A1T500007	Y303450A1T50000G	M45x2	M20x1.5	M25x1.5	Y303M45F1T000007	Y303M45F1T00000G
45	M25x1.5	23.5	Y303450D1T500007	Y303450D1T50000G	M45x2	M25x1.5	0	Y303M4501T500007	Y303M4501T50000G
45	M25x1.5	M25x1.5	Y303450F1T500007	Y303450F1T50000G	M45x2	M25x1.5	10	Y303M45A1T500007	Y303M45A1T50000G
50	0	0	Y303500000000007	Y30350000000000G	M45x2	M25x1.5	23.5	Y303M45D1T500007	Y303M45D1T50000G
50	0	10	Y303500A000000007	Y303500A00000000G	M45x2	M25x1.5	M25x1.5	Y303M45F1T500007	Y303M45F1T50000G
50	0	23.5	Y303500D000000007	Y303500D00000000G	1½" BSPP	0	0	Y303BA2000000007	Y303BA200000000G
50	0	M25x1.5	Y303500F000000007	Y303500F00000000G	1½" BSPP	0	10	Y303BA2A000000007	Y303BA2A00000000G
50	20	0	Y303500012000007	Y30350001200000G	1½" BSPP	0	23.5	Y303BA2D000000007	Y303BA2D00000000G
50	20	10	Y303500A12000007	Y303500A1200000G	1½" BSPP	0	M25x1.5	Y303BA2F000000007	Y303BA2F00000000G
50	20	23.5	Y303500D12000007	Y303500D1200000G	1½" BSPP	20	0	Y303BA2012000007	Y303BA201200000G
50	20	M25x1.5	Y303500F12000007	Y303500F1200000G	1½" BSPP	20	10	Y303BA2A12000007	Y303BA2A1200000G
50	25	0	Y303500012500007	Y30350001250000G	1½" BSPP	20	23.5	Y303BA2D12000007	Y303BA2D1200000G
50	25	10	Y303500A12500007	Y303500A1250000G	1½" BSPP	20	M25x1.5	Y303BA2F12000007	Y303BA2F1200000G
50	25	23.5	Y303500D12500007	Y303500D1250000G	1½" BSPP	25	0	Y303BA2012500007	Y303BA201250000G
50	25	M25x1.5	Y303500F12500007	Y303500F1250000G	1½" BSPP	25	10	Y303BA2A12500007	Y303BA2A1250000G
50	M20x1.5	0	Y30350001T000007	Y30350001T00000G	1½" BSPP	25	23.5	Y303BA2D12500007	Y303BA2D1250000G
50	M20x1.5	10	Y303500A1T000007	Y303500A1T00000G	1½" BSPP	25	M25x1.5	Y303BA2F12500007	Y303BA2F1250000G
50	M20x1.5	23.5	Y303500D1T000007	Y303500D1T00000G	1½" BSPP	M20x1.5	0	Y303BA201T000007	Y303BA201T00000G
50	M20x1.5	M25x1.5	Y303500F1T000007	Y303500F1T00000G	1½" BSPP	M20x1.5	10	Y303BA2A1T000007	Y303BA2A1T00000G
50	M25x1.5	0	Y30350001T500007	Y30350001T50000G	1½" BSPP	M20x1.5	23.5	Y303BA2D1T000007	Y303BA2D1T00000G
50	M25x1.5	10	Y303500A1T500007	Y303500A1T50000G	1½" BSPP	M20x1.5	M25x1.5	Y303BA2F1T000007	Y303BA2F1T00000G
50	M25x1.5	23.5	Y303500D1T500007	Y303500D1T50000G	1½" BSPP	M25x1.5	0	Y303BA201T500007	Y303BA201T50000G
50	M25x1.5	M25x1.5	Y303500F1T500007	Y303500F1T50000G	1½" BSPP	M25x1.5	10	Y303BA2A1T500007	Y303BA2A1T50000G
M45x2	0	0	Y303M450000000007	Y303M45000000000G	1½" BSPP	M25x1.5	23.5	Y303BA2D1T500007	Y303BA2D1T50000G
M45x2	0	10	Y303M45A000000007	Y303M45A00000000G	1½" BSPP	M25x1.5	M25x1.5	Y303BA2F1T500007	Y303BA2F1T50000G

Because of permanent improvement of our products, drawings, descriptions, features used on these data sheets are for guidance only and can be modified without prior advice



# Enclosure for immersion heater, level sensor or temperature sensor

Size(mm)	Volume(cm <sup>3</sup> )	Material	Protection grade		Model
<b>78 x 78 x 74</b>	<b>410</b>	<b>Aluminum</b>	<b>IP69K</b>	<b>IK10</b>	<b>Y304</b> <span style="color: red;">(P1)</span>

Suitable for
<input checked="" type="checkbox"/> Temperature sensor
<input checked="" type="checkbox"/> Immersion heater
<input type="checkbox"/> Finned heater
<input checked="" type="checkbox"/> Thermostat
<input checked="" type="checkbox"/> Level sensor
<input checked="" type="checkbox"/> Electronic board

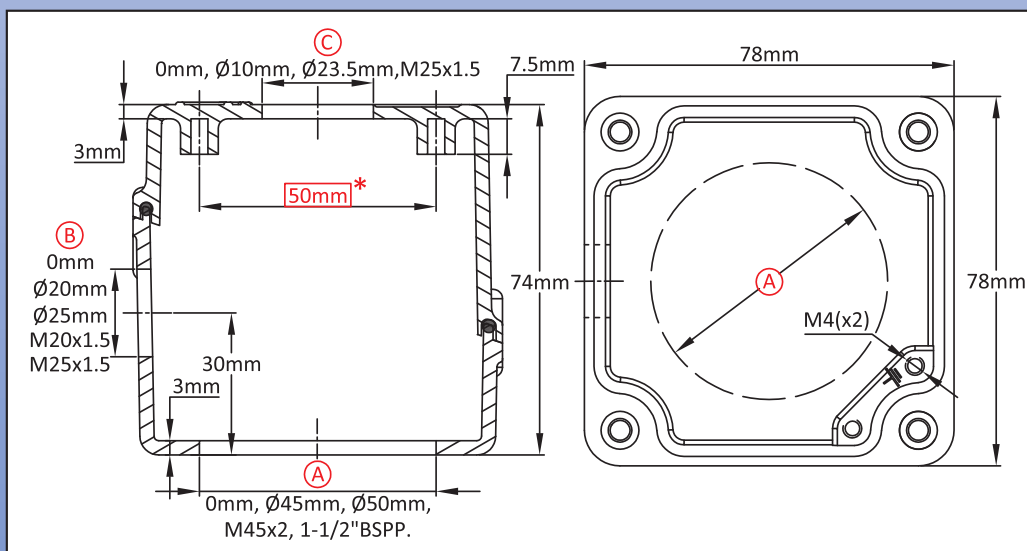

### Links

	Page (.pdf)
	Drawing 2D (.dwg)
	Drawing 3D (.stp)

### Main references

(A) (mm)	(B) (mm)	(C) (mm)	Not painted	Painted	(A) (mm)	(B) (mm)	(C) (mm)	Not painted	Painted
0	0	0	Y304000000000007	Y30400000000000G	0	M20x1.5	0	Y30400001T000007	Y30400001T00000G
0	0	10	Y304000A00000007	Y304000A0000000G	0	M20x1.5	10	Y304000A1T000007	Y304000A1T00000G
0	0	23.5	Y304000D00000007	Y304000D0000000G	0	M20x1.5	23.5	Y304000D1T000007	Y304000D1T00000G
0	0	M25x1.5	Y304000F00000007	Y304000F0000000G	0	M20x1.5	M25x1.5	Y304000F1T000007	Y304000F1T00000G
0	20	0	Y304000012000007	Y30400001200000G	0	M25x1.5	0	Y30400001T500007	Y30400001T50000G
0	20	10	Y304000A12000007	Y304000A1200000G	0	M25x1.5	10	Y304000A1T500007	Y304000A1T50000G
0	20	23.5	Y304000D12000007	Y304000D1200000G	0	M25x1.5	23.5	Y304000D1T500007	Y304000D1T50000G
0	20	M25x1.5	Y304000F12000007	Y304000F1200000G	0	M25x1.5	M25x1.5	Y304000F1T500007	Y304000F1T50000G
0	25	0	Y304000012500007	Y30400001250000G	45	0	0	Y304450000000007	Y30445000000000G
0	25	10	Y304000A12500007	Y304000A1250000G	45	0	10	Y304450A00000007	Y304450A0000000G
0	25	23.5	Y304000D12500007	Y304000D1250000G	45	0	23.5	Y304450D00000007	Y304450D0000000G
0	25	M25x1.5	Y304000F12500007	Y304000F1250000G	45	0	M25x1.5	Y304450F00000007	Y304450F0000000G

Cable gland not included in these reference, consult us if you want them.

Red dimensions inside rectangular frames are used for accessories assembly.

Because of permanent improvement of our products, drawings, descriptions, features used on these data sheets are for guidance only and can be modified without prior advice

# Enclosure for immersion heater, level sensor or temperature sensor

**Y304  
(P2)**

(A) (mm)	(B) (mm)	(C) (mm)	Not painted	Painted	(A) (mm)	(B) (mm)	(C) (mm)	Not painted	Painted
45	20	0	Y304450012000007	Y30445001200000G	M45x2	0	23.5	Y304M45D000000007	Y304M45D00000000G
45	20	10	Y304450A12000007	Y304450A1200000G	M45x2	0	M25x1.5	Y304M45F000000007	Y304M45F00000000G
45	20	23.5	Y304450D12000007	Y304450D1200000G	M45x2	20	0	Y304M45012000007	Y304M4501200000G
45	20	M25x1.5	Y304450F12000007	Y304450F1200000G	M45x2	20	10	Y304M45A12000007	Y304M45A1200000G
45	25	0	Y304450012500007	Y30445001250000G	M45x2	20	23.5	Y304M45D12000007	Y304M45D1200000G
45	25	10	Y304450A12500007	Y304450A1250000G	M45x2	20	M25x1.5	Y304M45F12000007	Y304M45F1200000G
45	25	23.5	Y304450D12500007	Y304450D1250000G	M45x2	25	0	Y304M45012500007	Y304M4501250000G
45	25	M25x1.5	Y304450F12500007	Y304450F1250000G	M45x2	25	10	Y304M45A12500007	Y304M45A1250000G
45	M20x1.5	0	Y30445001T000007	Y30445001T00000G	M45x2	25	23.5	Y304M45D12500007	Y304M45D1250000G
45	M20x1.5	10	Y304450A1T000007	Y304450A1T00000G	M45x2	25	M25x1.5	Y304M45F12500007	Y304M45F1250000G
45	M20x1.5	23.5	Y304450D1T000007	Y304450D1T00000G	M45x2	M20x1.5	0	Y304M4501T000007	Y304M4501T00000G
45	M20x1.5	M25x1.5	Y304450F1T000007	Y304450F1T00000G	M45x2	M20x1.5	10	Y304M45A1T000007	Y304M45A1T00000G
45	M25x1.5	0	Y30445001T500007	Y30445001T50000G	M45x2	M20x1.5	23.5	Y304M45D1T000007	Y304M45D1T00000G
45	M25x1.5	10	Y304450A1T500007	Y304450A1T50000G	M45x2	M20x1.5	M25x1.5	Y304M45F1T000007	Y304M45F1T00000G
45	M25x1.5	23.5	Y304450D1T500007	Y304450D1T50000G	M45x2	M25x1.5	0	Y304M4501T500007	Y304M4501T50000G
45	M25x1.5	M25x1.5	Y304450F1T500007	Y304450F1T50000G	M45x2	M25x1.5	10	Y304M45A1T500007	Y304M45A1T50000G
50	0	0	Y304500000000007	Y30450000000000G	M45x2	M25x1.5	23.5	Y304M45D1T500007	Y304M45D1T50000G
50	0	10	Y304500A000000007	Y304500A00000000G	M45x2	M25x1.5	M25x1.5	Y304M45F1T500007	Y304M45F1T50000G
50	0	23.5	Y304500D000000007	Y304500D00000000G	1½" BSPP	0	0	Y304BA2000000007	Y304BA200000000G
50	0	M25x1.5	Y304500F000000007	Y304500F00000000G	1½" BSPP	0	10	Y304BA2A000000007	Y304BA2A00000000G
50	20	0	Y304500012000007	Y30450001200000G	1½" BSPP	0	23.5	Y304BA2D000000007	Y304BA2D00000000G
50	20	10	Y304500A12000007	Y304500A1200000G	1½" BSPP	0	M25x1.5	Y304BA2F000000007	Y304BA2F00000000G
50	20	23.5	Y304500D12000007	Y304500D1200000G	1½" BSPP	20	0	Y304BA2012000007	Y304BA201200000G
50	20	M25x1.5	Y304500F12000007	Y304500F1200000G	1½" BSPP	20	10	Y304BA2A12000007	Y304BA2A1200000G
50	25	0	Y304500012500007	Y30450001250000G	1½" BSPP	20	23.5	Y304BA2D12000007	Y304BA2D1200000G
50	25	10	Y304500A12500007	Y304500A1250000G	1½" BSPP	20	M25x1.5	Y304BA2F12000007	Y304BA2F1200000G
50	25	23.5	Y304500D12500007	Y304500D1250000G	1½" BSPP	25	0	Y304BA2012500007	Y304BA201250000G
50	25	M25x1.5	Y304500F12500007	Y304500F1250000G	1½" BSPP	25	10	Y304BA2A12500007	Y304BA2A1250000G
50	M20x1.5	0	Y30450001T000007	Y30450001T00000G	1½" BSPP	25	23.5	Y304BA2D12500007	Y304BA2D1250000G
50	M20x1.5	10	Y304500A1T000007	Y304500A1T00000G	1½" BSPP	25	M25x1.5	Y304BA2F12500007	Y304BA2F1250000G
50	M20x1.5	23.5	Y304500D1T000007	Y304500D1T00000G	1½" BSPP	M20x1.5	0	Y304BA201T000007	Y304BA201T00000G
50	M20x1.5	M25x1.5	Y304500F1T000007	Y304500F1T00000G	1½" BSPP	M20x1.5	10	Y304BA2A1T000007	Y304BA2A1T00000G
50	M25x1.5	0	Y30450001T500007	Y30450001T50000G	1½" BSPP	M20x1.5	23.5	Y304BA2D1T000007	Y304BA2D1T00000G
50	M25x1.5	10	Y304500A1T500007	Y304500A1T50000G	1½" BSPP	M20x1.5	M25x1.5	Y304BA2F1T000007	Y304BA2F1T00000G
50	M25x1.5	23.5	Y304500D1T500007	Y304500D1T50000G	1½" BSPP	M25x1.5	0	Y304BA201T500007	Y304BA201T50000G
50	M25x1.5	M25x1.5	Y304500F1T500007	Y304500F1T50000G	1½" BSPP	M25x1.5	10	Y304BA2A1T500007	Y304BA2A1T50000G
M45x2	0	0	Y304M45000000007	Y304M4500000000G	1½" BSPP	M25x1.5	23.5	Y304BA2D1T500007	Y304BA2D1T50000G
M45x2	0	10	Y304M45A000000007	Y304M45A00000000G	1½" BSPP	M25x1.5	M25x1.5	Y304BA2F1T500007	Y304BA2F1T50000G

Because of permanent improvement of our products, drawings, descriptions, features used on these data sheets are for guidance only and can be modified without prior advice

# Enclosure for immersion heater

Size(mm)	Volume(cm <sup>3</sup> )	Material	Protection grade		Model
<b>105 x 105 x 96</b>	<b>858</b>	<b>Aluminum</b>	<b>IP69K</b>	<b>IK10</b>	<b>Y305</b> <b>(P1)</b>

### Suitable for

- Temperature sensor
- Immersion heater
- Finned heater
- Thermostat
- Level sensor
- Electronic board

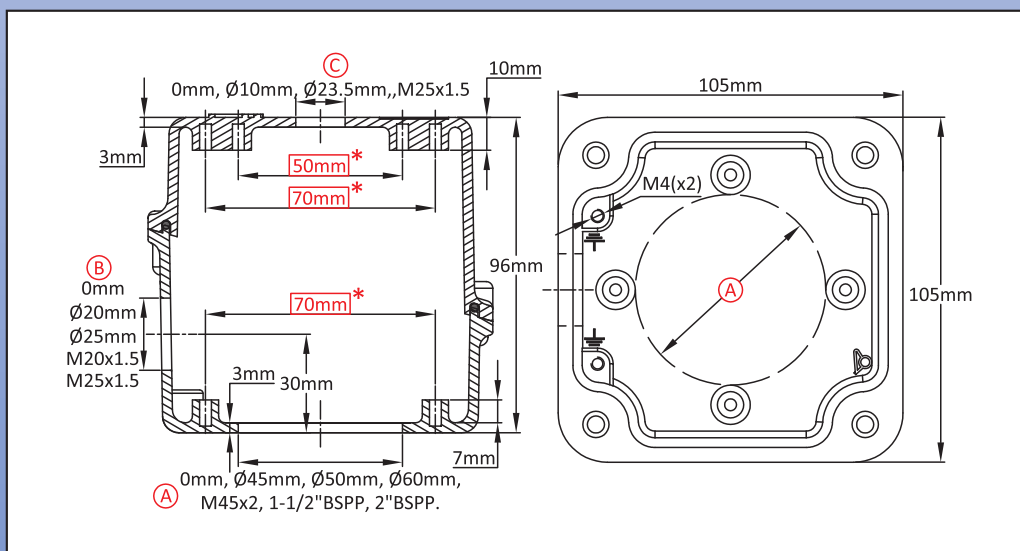

### Links



Page  
(.pdf)



Drawing 2D  
(.dwg)



Drawing 3D  
(.stp)

### Main references

(A) (mm)	(B) (mm)	(C) (mm)	Not painted	Painted	(A) (mm)	(B) (mm)	(C) (mm)	Not painted	Painted
0	0	0	Y305000000000007	Y30500000000000G	0	M25x1.5	0	Y30500001T500007	Y30500001T50000G
0	0	10	Y305000A00000007	Y305000A0000000G	0	M25x1.5	10	Y305000A1T500007	Y305000A1T50000G
0	0	23.5	Y305000D00000007	Y305000D0000000G	0	M25x1.5	23.5	Y305000D1T500007	Y305000D1T50000G
0	0	M25x1.5	Y305000F00000007	Y305000F0000000G	0	M25x1.5	M25x1.5	Y305000F1T500007	Y305000F1T50000G
0	20	0	Y305000012000007	Y30500001200000G	45	0	0	Y305450000000007	Y30545000000000G
0	20	10	Y305000A12000007	Y305000A1200000G	45	0	10	Y305450A00000007	Y305450A0000000G
0	20	23.5	Y305000D12000007	Y305000D1200000G	45	0	23.5	Y305450D00000007	Y305450D0000000G
0	20	M25x1.5	Y305000F12000007	Y305000F1200000G	45	0	M25x1.5	Y305450F00000007	Y305450F0000000G
0	25	0	Y305000012500007	Y30500001250000G	45	20	0	Y305450012000007	Y30545001200000G
0	25	10	Y305000A12500007	Y305000A1250000G	45	20	10	Y305450A12000007	Y305450A1200000G
0	25	23.5	Y305000D12500007	Y305000D1250000G	45	20	23.5	Y305450D12000007	Y305450D1200000G
0	25	M25x1.5	Y305000F12500007	Y305000F1250000G	45	20	M25x1.5	Y305450F12000007	Y305450F1200000G
0	M20x1.5	0	Y30500001T000007	Y30500001T00000G	45	25	0	Y305450012500007	Y30545001250000G
0	M20x1.5	10	Y305000A1T000007	Y305000A1T00000G	45	25	10	Y305450A12500007	Y305450A1250000G
0	M20x1.5	23.5	Y305000D1T000007	Y305000D1T00000G	45	25	23.5	Y305450D12500007	Y305450D1250000G
0	M20x1.5	M25x1.5	Y305000F1T000007	Y305000F1T00000G	45	25	M25x1.5	Y305450F12500007	Y305450F1250000G

Cable gland not included in these reference, consult us if you want them.

Red dimensions inside rectangular frames are used for accessories assembly.

# Enclosure for immersion heater

**Y305  
(P2)**

Ⓐ (mm)	Ⓑ (mm)	Ⓒ (mm)	Not painted	Painted	Ⓐ (mm)	Ⓑ (mm)	Ⓒ (mm)	Not painted	Painted
45	M20x1.5	0	Y30545001T000007	Y30545001T00000G	M45x2	20	23.5	Y305M45D12000007	Y305M45D1200000G
45	M20x1.5	10	Y305450A1T000007	Y305450A1T00000G	M45x2	20	M25x1.5	Y305M45F12000007	Y305M45F1200000G
45	M20x1.5	23.5	Y305450D1T000007	Y305450D1T00000G	M45x2	25	0	Y305M45012500007	Y305M4501250000G
45	M20x1.5	M25x1.5	Y305450F1T000007	Y305450F1T00000G	M45x2	25	10	Y305M45A12500007	Y305M45A1250000G
45	M25x1.5	0	Y30545001T500007	Y30545001T50000G	M45x2	25	23.5	Y305M45D12500007	Y305M45D1250000G
45	M25x1.5	10	Y305450A1T500007	Y305450A1T50000G	M45x2	25	M25x1.5	Y305M45F12500007	Y305M45F1250000G
45	M25x1.5	23.5	Y305450D1T500007	Y305450D1T50000G	M45x2	M20x1.5	0	Y305M4501T000007	Y305M4501T00000G
45	M25x1.5	M25x1.5	Y305450F1T500007	Y305450F1T50000G	M45x2	M20x1.5	10	Y305M45A1T000007	Y305M45A1T00000G
50	0	0	Y3055000000000007	Y305500000000000G	M45x2	M20x1.5	23.5	Y305M45D1T000007	Y305M45D1T00000G
50	0	10	Y305500A00000007	Y305500A0000000G	M45x2	M20x1.5	M25x1.5	Y305M45F1T000007	Y305M45F1T00000G
50	0	23.5	Y305500D00000007	Y305500D0000000G	M45x2	M25x1.5	0	Y305M4501T500007	Y305M4501T50000G
50	0	M25x1.5	Y305500F00000007	Y305500F0000000G	M45x2	M25x1.5	10	Y305M45A1T500007	Y305M45A1T50000G
50	20	0	Y305500012000007	Y30550001200000G	M45x2	M25x1.5	23.5	Y305M45D1T500007	Y305M45D1T50000G
50	20	10	Y305500A12000007	Y305500A1200000G	M45x2	M25x1.5	M25x1.5	Y305M45F1T500007	Y305M45F1T50000G
50	20	23.5	Y305500D12000007	Y305500D1200000G	1½" BSPP	0	0	Y305BA2000000007	Y305BA200000000G
50	20	M25x1.5	Y305500F12000007	Y305500F1200000G	1½" BSPP	0	10	Y305BA2A00000007	Y305BA2A0000000G
50	25	0	Y305500012500007	Y30550001250000G	1½" BSPP	0	23.5	Y305BA2D00000007	Y305BA2D0000000G
50	25	10	Y305500A12500007	Y305500A1250000G	1½" BSPP	0	M25x1.5	Y305BA2F00000007	Y305BA2F0000000G
50	25	23.5	Y305500D12500007	Y305500D1250000G	1½" BSPP	20	0	Y305BA2012000007	Y305BA201200000G
50	25	M25x1.5	Y305500F12500007	Y305500F1250000G	1½" BSPP	20	10	Y305BA2A12000007	Y305BA2A1200000G
50	M20x1.5	0	Y30550001T000007	Y30550001T00000G	1½" BSPP	20	23.5	Y305BA2D12000007	Y305BA2D1200000G
50	M20x1.5	10	Y305500A1T000007	Y305500A1T00000G	1½" BSPP	20	M25x1.5	Y305BA2F12000007	Y305BA2F1200000G
50	M20x1.5	23.5	Y305500D1T000007	Y305500D1T00000G	1½" BSPP	25	0	Y305BA2012500007	Y305BA201250000G
50	M20x1.5	M25x1.5	Y305500F1T000007	Y305500F1T00000G	1½" BSPP	25	10	Y305BA2A12500007	Y305BA2A1250000G
50	M25x1.5	0	Y30550001T500007	Y30550001T50000G	1½" BSPP	25	23.5	Y305BA2D12500007	Y305BA2D1250000G
50	M25x1.5	10	Y305500A1T500007	Y305500A1T50000G	1½" BSPP	25	M25x1.5	Y305BA2F12500007	Y305BA2F1250000G
50	M25x1.5	23.5	Y305500D1T500007	Y305500D1T50000G	1½" BSPP	M20x1.5	0	Y305BA201T000007	Y305BA201T00000G
50	M25x1.5	M25x1.5	Y305500F1T500007	Y305500F1T50000G	1½" BSPP	M20x1.5	10	Y305BA2A1T000007	Y305BA2A1T00000G
60	0	0	Y3056000000000007	Y305600000000000G	1½" BSPP	M20x1.5	23.5	Y305BA2D1T000007	Y305BA2D1T00000G
60	0	10	Y305600A00000007	Y305600A0000000G	1½" BSPP	M20x1.5	M25x1.5	Y305BA2F1T000007	Y305BA2F1T00000G
60	0	23.5	Y305600D00000007	Y305600D0000000G	1½" BSPP	M25x1.5	0	Y305BA201T500007	Y305BA201T50000G
60	0	M25x1.5	Y305600F00000007	Y305600F0000000G	1½" BSPP	M25x1.5	10	Y305BA2A1T500007	Y305BA2A1T50000G
60	20	0	Y305600012000007	Y30560001200000G	1½" BSPP	M25x1.5	23.5	Y305BA2D1T500007	Y305BA2D1T50000G
60	20	10	Y305600A12000007	Y305600A1200000G	1½" BSPP	M25x1.5	M25x1.5	Y305BA2F1T500007	Y305BA2F1T50000G
60	20	23.5	Y305600D12000007	Y305600D1200000G	2" BSPP	0	0	Y305BB2000000007	Y305BB200000000G
60	20	M25x1.5	Y305600F12000007	Y305600F1200000G	2" BSPP	0	10	Y305BB2A00000007	Y305BB2A0000000G
60	25	0	Y305600012500007	Y30560001250000G	2" BSPP	0	23.5	Y305BB2D00000007	Y305BB2D0000000G
60	25	10	Y305600A12500007	Y305600A1250000G	2" BSPP	0	M25x1.5	Y305BB2F00000007	Y305BB2F0000000G
60	25	23.5	Y305600D12500007	Y305600D1250000G	2" BSPP	20	0	Y305BB2012000007	Y305BB201200000G
60	25	M25x1.5	Y305600F12500007	Y305600F1250000G	2" BSPP	20	10	Y305BB2A12000007	Y305BB2A1200000G
60	M20x1.5	0	Y30560001T000007	Y30560001T00000G	2" BSPP	20	23.5	Y305BB2D12000007	Y305BB2D1200000G
60	M20x1.5	10	Y305600A1T000007	Y305600A1T00000G	2" BSPP	20	M25x1.5	Y305BB2F12000007	Y305BB2F1200000G
60	M20x1.5	23.5	Y305600D1T000007	Y305600D1T00000G	2" BSPP	25	0	Y305BB2012500007	Y305BB201250000G
60	M20x1.5	M25x1.5	Y305600F1T000007	Y305600F1T00000G	2" BSPP	25	10	Y305BB2A12500007	Y305BB2A1250000G
60	M25x1.5	0	Y30560001T500007	Y30560001T50000G	2" BSPP	25	23.5	Y305BB2D12500007	Y305BB2D1250000G
60	M25x1.5	10	Y305600A1T500007	Y305600A1T50000G	2" BSPP	25	M25x1.5	Y305BB2F12500007	Y305BB2F1250000G
60	M25x1.5	23.5	Y305600D1T500007	Y305600D1T50000G	2" BSPP	M20x1.5	0	Y305BB201T000007	Y305BB201T00000G
60	M25x1.5	M25x1.5	Y305600F1T500007	Y305600F1T50000G	2" BSPP	M20x1.5	10	Y305BB2A1T000007	Y305BB2A1T00000G
M45x2	0	0	Y305M450000000007	Y305M45000000000G	2" BSPP	M20x1.5	23.5	Y305BB2D1T000007	Y305BB2D1T00000G
M45x2	0	10	Y305M45A00000007	Y305M45A0000000G	2" BSPP	M20x1.5	M25x1.5	Y305BB2F1T000007	Y305BB2F1T00000G
M45x2	0	23.5	Y305M45D00000007	Y305M45D0000000G	2" BSPP	M25x1.5	0	Y305BB201T500007	Y305BB201T50000G
M45x2	0	M25x1.5	Y305M45F00000007	Y305M45F0000000G	2" BSPP	M25x1.5	10	Y305BB2A1T500007	Y305BB2A1T50000G
M45x2	20	0	Y305M45012000007	Y305M4501200000G	2" BSPP	M25x1.5	23.5	Y305BB2D1T500007	Y305BB2D1T50000G
M45x2	20	10	Y305M45A12000007	Y305M45A1200000G	2" BSPP	M25x1.5	M25x1.5	Y305BB2F1T500007	Y305BB2F1T50000G

Because of permanent improvement of our products, drawings, descriptions, features used on these data sheets are for guidance only and can be modified without prior advice

## Small size enclosure for immersion heater, finned heaters or controls

Size(mm)	Volume(cm <sup>3</sup> )	Material	Protection grade		Model
<b>64 x 84 x 104</b>	<b>510</b>	<b>Aluminum</b>	<b>IP69K</b>	<b>IK10</b>	<b>Y3P1</b> <b>(P1)</b>

### Suitable for

- Temperature sensor
- Immersion heater
- Finned heater
- Thermostat
- Level sensor
- Electronic board

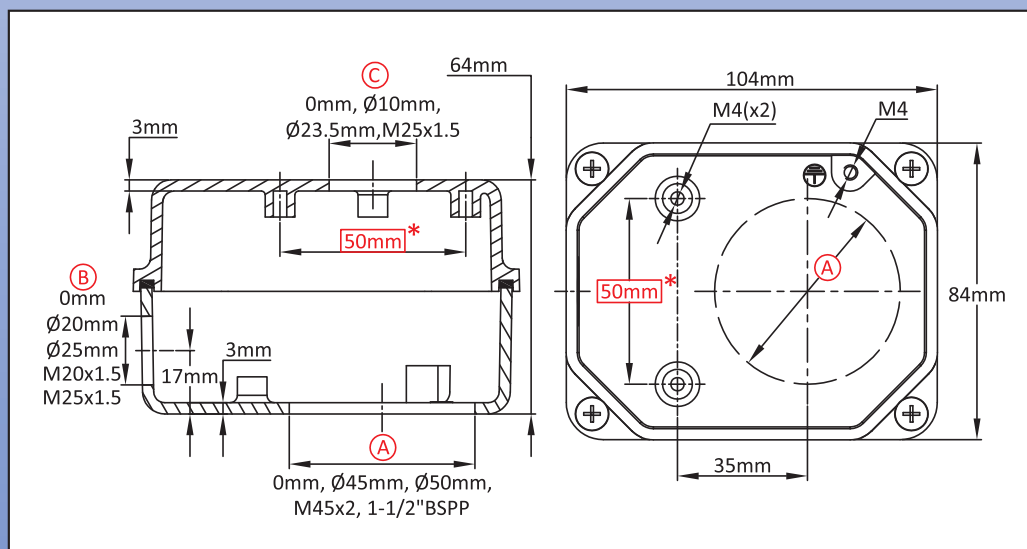

### Links



Page  
(.pdf)



Drawing 2D  
(.dwg)



Drawing 3D  
(.stp)

### Main references

(A) (mm)	(B) (mm)	(C) (mm)	Not painted	Painted	(A) (mm)	(B) (mm)	(C) (mm)	Not painted	Painted
0	0	0	Y3P1000000000007	Y3P100000000000G	0	M20x1.5	0	Y3P100001T000007	Y3P100001T00000G
0	0	10	Y3P1000A00000007	Y3P1000A0000000G	0	M20x1.5	10	Y3P1000A1T000007	Y3P1000A1T00000G
0	0	23.5	Y3P1000D00000007	Y3P1000D0000000G	0	M20x1.5	23.5	Y3P1000D1T000007	Y3P1000D1T00000G
0	0	M25x1.5	Y3P1000F00000007	Y3P1000F0000000G	0	M20x1.5	M25x1.5	Y3P1000F1T000007	Y3P1000F1T00000G
0	20	0	Y3P1000012000007	Y3P100001200000G	0	M25x1.5	0	Y3P100001T500007	Y3P100001T50000G
0	20	10	Y3P1000A12000007	Y3P1000A1200000G	0	M25x1.5	10	Y3P1000A1T500007	Y3P1000A1T50000G
0	20	23.5	Y3P1000D12000007	Y3P1000D1200000G	0	M25x1.5	23.5	Y3P1000D1T500007	Y3P1000D1T50000G
0	20	M25x1.5	Y3P1000F12000007	Y3P1000F1200000G	0	M25x1.5	M25x1.5	Y3P1000F1T500007	Y3P1000F1T50000G
0	25	0	Y3P1000012500007	Y3P100001250000G	45	0	0	Y3P1450000000007	Y3P145000000000G
0	25	10	Y3P1000A12500007	Y3P1000A1250000G	45	0	10	Y3P1450A00000007	Y3P1450A0000000G
0	25	23.5	Y3P1000D12500007	Y3P1000D1250000G	45	0	23.5	Y3P1450D00000007	Y3P1450D0000000G
0	25	M25x1.5	Y3P1000F12500007	Y3P1000F1250000G	45	0	M25x1.5	Y3P1450F00000007	Y3P1450F0000000G

Cable gland not included in these reference, consult us if you want them.

Red dimensions inside rectangular frames are used for accessories assembly.

# Small size enclosure for immersion heater, finned heaters or controls

**Y3P1  
(P2)**

(A) (mm)	(B) (mm)	(C) (mm)	Not painted	Painted	(A) (mm)	(B) (mm)	(C) (mm)	Not painted	Painted
45	20	0	Y3P1450012000007	Y3P145001200000G	M45x2	0	23.5	Y3P1M45D00000007	Y3P1M45D0000000G
45	20	10	Y3P1450A12000007	Y3P1450A1200000G	M45x2	0	M25x1.5	Y3P1M45F00000007	Y3P1M45F0000000G
45	20	23.5	Y3P1450D12000007	Y3P1450D1200000G	M45x2	20	0	Y3P1M45012000007	Y3P1M4501200000G
45	20	M25x1.5	Y3P1450F12000007	Y3P1450F1200000G	M45x2	20	10	Y3P1M45A12000007	Y3P1M45A1200000G
45	25	0	Y3P1450012500007	Y3P145001250000G	M45x2	20	23.5	Y3P1M45D12000007	Y3P1M45D1200000G
45	25	10	Y3P1450A12500007	Y3P1450A1250000G	M45x2	20	M25x1.5	Y3P1M45F12000007	Y3P1M45F1200000G
45	25	23.5	Y3P1450D12500007	Y3P1450D1250000G	M45x2	25	0	Y3P1M45012500007	Y3P1M4501250000G
45	25	M25x1.5	Y3P1450F12500007	Y3P1450F1250000G	M45x2	25	10	Y3P1M45A12500007	Y3P1M45A1250000G
45	M20x1.5	0	Y3P145001T000007	Y3P145001T00000G	M45x2	25	23.5	Y3P1M45D12500007	Y3P1M45D1250000G
45	M20x1.5	10	Y3P1450A1T000007	Y3P1450A1T00000G	M45x2	25	M25x1.5	Y3P1M45F12500007	Y3P1M45F1250000G
45	M20x1.5	23.5	Y3P1450D1T000007	Y3P1450D1T00000G	M45x2	M20x1.5	0	Y3P1M4501T000007	Y3P1M4501T00000G
45	M20x1.5	M25x1.5	Y3P1450F1T000007	Y3P1450F1T00000G	M45x2	M20x1.5	10	Y3P1M45A1T000007	Y3P1M45A1T00000G
45	M25x1.5	0	Y3P145001T500007	Y3P145001T50000G	M45x2	M20x1.5	23.5	Y3P1M45D1T000007	Y3P1M45D1T00000G
45	M25x1.5	10	Y3P1450A1T500007	Y3P1450A1T50000G	M45x2	M20x1.5	M25x1.5	Y3P1M45F1T000007	Y3P1M45F1T00000G
45	M25x1.5	23.5	Y3P1450D1T500007	Y3P1450D1T50000G	M45x2	M25x1.5	0	Y3P1M4501T500007	Y3P1M4501T50000G
45	M25x1.5	M25x1.5	Y3P1450F1T500007	Y3P1450F1T50000G	M45x2	M25x1.5	10	Y3P1M45A1T500007	Y3P1M45A1T50000G
50	0	0	Y3P1500000000007	Y3P150000000000G	M45x2	M25x1.5	23.5	Y3P1M45D1T500007	Y3P1M45D1T50000G
50	0	10	Y3P1500A00000007	Y3P1500A0000000G	M45x2	M25x1.5	M25x1.5	Y3P1M45F1T500007	Y3P1M45F1T50000G
50	0	23.5	Y3P1500D00000007	Y3P1500D0000000G	1½" BSPP	0	0	Y3P1BA2000000007	Y3P1BA200000000G
50	0	M25x1.5	Y3P1500F00000007	Y3P1500F0000000G	1½" BSPP	0	10	Y3P1BA2A00000007	Y3P1BA2A0000000G
50	20	0	Y3P1500012000007	Y3P150001200000G	1½" BSPP	0	23.5	Y3P1BA2D00000007	Y3P1BA2D0000000G
50	20	10	Y3P1500A12000007	Y3P1500A1200000G	1½" BSPP	0	M25x1.5	Y3P1BA2F00000007	Y3P1BA2F0000000G
50	20	23.5	Y3P1500D12000007	Y3P1500D1200000G	1½" BSPP	20	0	Y3P1BA2012000007	Y3P1BA201200000G
50	20	M25x1.5	Y3P1500F12000007	Y3P1500F1200000G	1½" BSPP	20	10	Y3P1BA2A12000007	Y3P1BA2A1200000G
50	25	0	Y3P1500012500007	Y3P150001250000G	1½" BSPP	20	23.5	Y3P1BA2D12000007	Y3P1BA2D1200000G
50	25	10	Y3P1500A12500007	Y3P1500A1250000G	1½" BSPP	20	M25x1.5	Y3P1BA2F12000007	Y3P1BA2F1200000G
50	25	23.5	Y3P1500D12500007	Y3P1500D1250000G	1½" BSPP	25	0	Y3P1BA2012500007	Y3P1BA201250000G
50	25	M25x1.5	Y3P1500F12500007	Y3P1500F1250000G	1½" BSPP	25	10	Y3P1BA2A12500007	Y3P1BA2A1250000G
50	M20x1.5	0	Y3P150001T000007	Y3P150001T00000G	1½" BSPP	25	23.5	Y3P1BA2D12500007	Y3P1BA2D1250000G
50	M20x1.5	10	Y3P1500A1T000007	Y3P1500A1T00000G	1½" BSPP	25	M25x1.5	Y3P1BA2F12500007	Y3P1BA2F1250000G
50	M20x1.5	23.5	Y3P1500D1T000007	Y3P1500D1T00000G	1½" BSPP	M20x1.5	0	Y3P1BA201T000007	Y3P1BA201T00000G
50	M20x1.5	M25x1.5	Y3P1500F1T000007	Y3P1500F1T00000G	1½" BSPP	M20x1.5	10	Y3P1BA2A1T000007	Y3P1BA2A1T00000G
50	M25x1.5	0	Y3P150001T500007	Y3P150001T50000G	1½" BSPP	M20x1.5	23.5	Y3P1BA2D1T000007	Y3P1BA2D1T00000G
50	M25x1.5	10	Y3P1500A1T500007	Y3P1500A1T50000G	1½" BSPP	M20x1.5	M25x1.5	Y3P1BA2F1T000007	Y3P1BA2F1T00000G
50	M25x1.5	23.5	Y3P1500D1T500007	Y3P1500D1T50000G	1½" BSPP	M25x1.5	0	Y3P1BA201T500007	Y3P1BA201T50000G
50	M25x1.5	M25x1.5	Y3P1500F1T500007	Y3P1500F1T50000G	1½" BSPP	M25x1.5	10	Y3P1BA2A1T500007	Y3P1BA2A1T50000G
M45x2	0	0	Y3P1M45000000007	Y3P1M4500000000G	1½" BSPP	M25x1.5	23.5	Y3P1BA2D1T500007	Y3P1BA2D1T50000G
M45x2	0	10	Y3P1M45A00000007	Y3P1M45A0000000G	1½" BSPP	M25x1.5	M25x1.5	Y3P1BA2F1T500007	Y3P1BA2F1T50000G

Because of permanent improvement of our products, drawings, descriptions, features used on these data sheets are for guidance only and can be modified without prior advice

# Medium size enclosure for immersion heater, finned heaters or controls

Size(mm)	Volume(cm <sup>3</sup> )	Material	Protection grade		Model
66 x 89 x 114	650	Aluminum	IP69K	IK10	<b>Y3P3</b> (P1)

Suitable for
<input type="checkbox"/> Temperature sensor
<input checked="" type="checkbox"/> Immersion heater
<input checked="" type="checkbox"/> Finned heater
<input checked="" type="checkbox"/> Thermostat
<input type="checkbox"/> Level sensor
<input checked="" type="checkbox"/> Electronic board

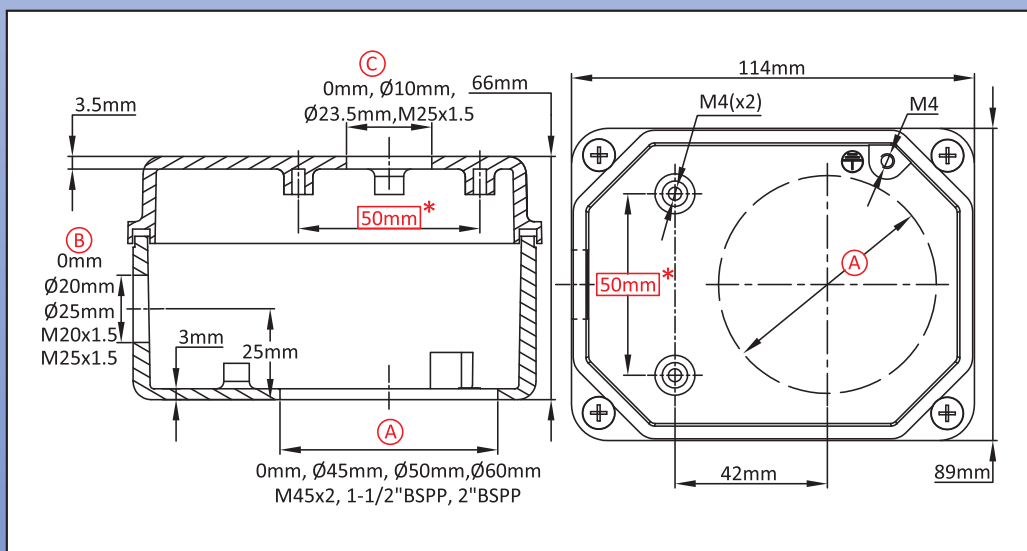

**Links**

 Page (.pdf)

 Drawing 2D (.dwg)

 Drawing 3D (.stp)

## Main references

(A) (mm)	(B) (mm)	(C) (mm)	Not painted	Painted	(A) (mm)	(B) (mm)	(C) (mm)	Not painted	Painted
0	0	0	Y3P3000000000007	Y3P300000000000G	0	M25x1.5	0	Y3P300001T500007	Y3P300001T50000G
0	0	10	Y3P3000A00000007	Y3P3000A0000000G	0	M25x1.5	10	Y3P3000A1T500007	Y3P3000A1T50000G
0	0	23.5	Y3P3000D00000007	Y3P3000D0000000G	0	M25x1.5	23.5	Y3P3000D1T500007	Y3P3000D1T50000G
0	0	M25x1.5	Y3P3000F00000007	Y3P3000F0000000G	0	M25x1.5	M25x1.5	Y3P3000F1T500007	Y3P3000F1T50000G
0	20	0	Y3P3000012000007	Y3P300001200000G	45	0	0	Y3P3450000000007	Y3P345000000000G
0	20	10	Y3P3000A12000007	Y3P3000A1200000G	45	0	10	Y3P3450A00000007	Y3P3450A0000000G
0	20	23.5	Y3P3000D12000007	Y3P3000D1200000G	45	0	23.5	Y3P3450D00000007	Y3P3450D0000000G
0	20	M25x1.5	Y3P3000F12000007	Y3P3000F1200000G	45	0	M25x1.5	Y3P3450F00000007	Y3P3450F0000000G
0	25	0	Y3P3000012500007	Y3P300001250000G	45	20	0	Y3P3450012000007	Y3P345001200000G
0	25	10	Y3P3000A12500007	Y3P3000A1250000G	45	20	10	Y3P3450A12000007	Y3P3450A1200000G
0	25	23.5	Y3P3000D12500007	Y3P3000D1250000G	45	20	23.5	Y3P3450D12000007	Y3P3450D1200000G
0	25	M25x1.5	Y3P3000F12500007	Y3P3000F1250000G	45	20	M25x1.5	Y3P3450F12000007	Y3P3450F1200000G
0	M20x1.5	0	Y3P300001T000007	Y3P300001T00000G	45	25	0	Y3P3450012500007	Y3P345001250000G
0	M20x1.5	10	Y3P3000A1T000007	Y3P3000A1T00000G	45	25	10	Y3P3450A12500007	Y3P3450A1250000G
0	M20x1.5	23.5	Y3P3000D1T000007	Y3P3000D1T00000G	45	25	23.5	Y3P3450D12500007	Y3P3450D1250000G
0	M20x1.5	M25x1.5	Y3P3000F1T000007	Y3P3000F1T00000G	45	25	M25x1.5	Y3P3450F12500007	Y3P3450F1250000G

Cable gland not included in these reference, consult us if you want them.

Red dimensions inside rectangular frames are used for accessories assembly.

Because of permanent improvement of our products, drawings, descriptions, features used on these data sheets are for guidance only and can be modified without prior advice

# Medium size enclosure for immersion heater, finned heaters or controls

**Y3P3  
(P2)**

Ⓐ (mm)	Ⓑ (mm)	Ⓒ (mm)	Not painted	Painted	Ⓐ (mm)	Ⓑ (mm)	Ⓒ (mm)	Not painted	Painted
45	M20x1.5	0	Y3P345001T000007	Y3P345001T00000G	M45x2	20	23.5	Y3P3M45D12000007	Y3P3M45D1200000G
45	M20x1.5	10	Y3P3450A1T000007	Y3P3450A1T00000G	M45x2	20	M25x1.5	Y3P3M45F12000007	Y3P3M45F1200000G
45	M20x1.5	23.5	Y3P3450D1T000007	Y3P3450D1T00000G	M45x2	25	0	Y3P3M45012500007	Y3P3M4501250000G
45	M20x1.5	M25x1.5	Y3P3450F1T000007	Y3P3450F1T00000G	M45x2	25	10	Y3P3M45A12500007	Y3P3M45A1250000G
45	M25x1.5	0	Y3P345001T500007	Y3P345001T50000G	M45x2	25	23.5	Y3P3M45D12500007	Y3P3M45D1250000G
45	M25x1.5	10	Y3P3450A1T500007	Y3P3450A1T50000G	M45x2	25	M25x1.5	Y3P3M45F12500007	Y3P3M45F1250000G
45	M25x1.5	23.5	Y3P3450D1T500007	Y3P3450D1T50000G	M45x2	M20x1.5	0	Y3P3M4501T000007	Y3P3M4501T00000G
45	M25x1.5	M25x1.5	Y3P3450F1T500007	Y3P3450F1T50000G	M45x2	M20x1.5	10	Y3P3M45A1T000007	Y3P3M45A1T00000G
50	0	0	Y3P3500000000007	Y3P350000000000G	M45x2	M20x1.5	23.5	Y3P3M45D1T000007	Y3P3M45D1T00000G
50	0	10	Y3P3500A00000007	Y3P3500A0000000G	M45x2	M20x1.5	M25x1.5	Y3P3M45F1T000007	Y3P3M45F1T00000G
50	0	23.5	Y3P3500D00000007	Y3P3500D0000000G	M45x2	M25x1.5	0	Y3P3M4501T500007	Y3P3M4501T50000G
50	0	M25x1.5	Y3P3500F00000007	Y3P3500F0000000G	M45x2	M25x1.5	10	Y3P3M45A1T500007	Y3P3M45A1T50000G
50	20	0	Y3P3500012000007	Y3P350001200000G	M45x2	M25x1.5	23.5	Y3P3M45D1T500007	Y3P3M45D1T50000G
50	20	10	Y3P3500A12000007	Y3P3500A1200000G	M45x2	M25x1.5	M25x1.5	Y3P3M45F1T500007	Y3P3M45F1T50000G
50	20	23.5	Y3P3500D12000007	Y3P3500D1200000G	1½" BSPP	0	0	Y3P3BA2000000007	Y3P3BA200000000G
50	20	M25x1.5	Y3P3500F12000007	Y3P3500F1200000G	1½" BSPP	0	10	Y3P3BA2A00000007	Y3P3BA2A0000000G
50	25	0	Y3P3500012500007	Y3P350001250000G	1½" BSPP	0	23.5	Y3P3BA2D00000007	Y3P3BA2D0000000G
50	25	10	Y3P3500A12500007	Y3P3500A1250000G	1½" BSPP	0	M25x1.5	Y3P3BA2F00000007	Y3P3BA2F0000000G
50	25	23.5	Y3P3500D12500007	Y3P3500D1250000G	1½" BSPP	20	0	Y3P3BA2012000007	Y3P3BA201200000G
50	25	M25x1.5	Y3P3500F12500007	Y3P3500F1250000G	1½" BSPP	20	10	Y3P3BA2A12000007	Y3P3BA2A1200000G
50	M20x1.5	0	Y3P350001T000007	Y3P350001T00000G	1½" BSPP	20	23.5	Y3P3BA2D12000007	Y3P3BA2D1200000G
50	M20x1.5	10	Y3P3500A1T000007	Y3P3500A1T00000G	1½" BSPP	20	M25x1.5	Y3P3BA2F12000007	Y3P3BA2F1200000G
50	M20x1.5	23.5	Y3P3500D1T000007	Y3P3500D1T00000G	1½" BSPP	25	0	Y3P3BA2012500007	Y3P3BA201250000G
50	M20x1.5	M25x1.5	Y3P3500F1T000007	Y3P3500F1T00000G	1½" BSPP	25	10	Y3P3BA2A12500007	Y3P3BA2A1250000G
50	M25x1.5	0	Y3P350001T500007	Y3P350001T50000G	1½" BSPP	25	23.5	Y3P3BA2D12500007	Y3P3BA2D1250000G
50	M25x1.5	10	Y3P3500A1T500007	Y3P3500A1T50000G	1½" BSPP	25	M25x1.5	Y3P3BA2F12500007	Y3P3BA2F1250000G
50	M25x1.5	23.5	Y3P3500D1T500007	Y3P3500D1T50000G	1½" BSPP	M20x1.5	0	Y3P3BA201T000007	Y3P3BA201T00000G
50	M25x1.5	M25x1.5	Y3P3500F1T500007	Y3P3500F1T50000G	1½" BSPP	M20x1.5	10	Y3P3BA2A1T000007	Y3P3BA2A1T00000G
60	0	0	Y3P3600000000007	Y3P360000000000G	1½" BSPP	M20x1.5	23.5	Y3P3BA2D1T000007	Y3P3BA2D1T00000G
60	0	10	Y3P3600A00000007	Y3P3600A0000000G	1½" BSPP	M20x1.5	M25x1.5	Y3P3BA2F1T000007	Y3P3BA2F1T00000G
60	0	23.5	Y3P3600D00000007	Y3P3600D0000000G	1½" BSPP	M25x1.5	0	Y3P3BA201T500007	Y3P3BA201T50000G
60	0	M25x1.5	Y3P3600F00000007	Y3P3600F0000000G	1½" BSPP	M25x1.5	10	Y3P3BA2A1T500007	Y3P3BA2A1T50000G
60	20	0	Y3P3600012000007	Y3P360001200000G	1½" BSPP	M25x1.5	23.5	Y3P3BA2D1T500007	Y3P3BA2D1T50000G
60	20	10	Y3P3600A12000007	Y3P3600A1200000G	1½" BSPP	M25x1.5	M25x1.5	Y3P3BA2F1T500007	Y3P3BA2F1T50000G
60	20	23.5	Y3P3600D12000007	Y3P3600D1200000G	2" BSPP	0	0	Y3P3BB2000000007	Y3P3BB200000000G
60	20	M25x1.5	Y3P3600F12000007	Y3P3600F1200000G	2" BSPP	0	10	Y3P3BB2A00000007	Y3P3BB2A0000000G
60	25	0	Y3P3600012500007	Y3P360001250000G	2" BSPP	0	23.5	Y3P3BB2D00000007	Y3P3BB2D0000000G
60	25	10	Y3P3600A12500007	Y3P3600A1250000G	2" BSPP	0	M25x1.5	Y3P3BB2F00000007	Y3P3BB2F0000000G
60	25	23.5	Y3P3600D12500007	Y3P3600D1250000G	2" BSPP	20	0	Y3P3BB2012000007	Y3P3BB201200000G
60	25	M25x1.5	Y3P3600F12500007	Y3P3600F1250000G	2" BSPP	20	10	Y3P3BB2A12000007	Y3P3BB2A1200000G
60	M20x1.5	0	Y3P360001T000007	Y3P360001T00000G	2" BSPP	20	23.5	Y3P3BB2D12000007	Y3P3BB2D1200000G
60	M20x1.5	10	Y3P3600A1T000007	Y3P3600A1T00000G	2" BSPP	20	M25x1.5	Y3P3BB2F12000007	Y3P3BB2F1200000G
60	M20x1.5	23.5	Y3P3600D1T000007	Y3P3600D1T00000G	2" BSPP	25	0	Y3P3BB2012500007	Y3P3BB201250000G
60	M20x1.5	M25x1.5	Y3P3600F1T000007	Y3P3600F1T00000G	2" BSPP	25	10	Y3P3BB2A12500007	Y3P3BB2A1250000G
60	M25x1.5	0	Y3P360001T500007	Y3P360001T50000G	2" BSPP	25	23.5	Y3P3BB2D12500007	Y3P3BB2D1250000G
60	M25x1.5	10	Y3P3600A1T500007	Y3P3600A1T50000G	2" BSPP	25	M25x1.5	Y3P3BB2F12500007	Y3P3BB2F1250000G
60	M25x1.5	23.5	Y3P3600D1T500007	Y3P3600D1T50000G	2" BSPP	M20x1.5	0	Y3P3BB201T000007	Y3P3BB201T00000G
60	M25x1.5	M25x1.5	Y3P3600F1T500007	Y3P3600F1T50000G	2" BSPP	M20x1.5	10	Y3P3BB2A1T000007	Y3P3BB2A1T00000G
M45x2	0	0	Y3P3M450000000007	Y3P3M45000000000G	2" BSPP	M20x1.5	23.5	Y3P3BB2D1T000007	Y3P3BB2D1T00000G
M45x2	0	10	Y3P3M45A00000007	Y3P3M45A0000000G	2" BSPP	M20x1.5	M25x1.5	Y3P3BB2F1T000007	Y3P3BB2F1T00000G
M45x2	0	23.5	Y3P3M45D00000007	Y3P3M45D0000000G	2" BSPP	M25x1.5	0	Y3P3BB201T500007	Y3P3BB201T50000G
M45x2	0	M25x1.5	Y3P3M45F00000007	Y3P3M45F0000000G	2" BSPP	M25x1.5	10	Y3P3BB2A1T500007	Y3P3BB2A1T50000G
M45x2	20	0	Y3P3M45012000007	Y3P3M4501200000G	2" BSPP	M25x1.5	23.5	Y3P3BB2D1T500007	Y3P3BB2D1T50000G
M45x2	20	10	Y3P3M45A12000007	Y3P3M45A1200000G	2" BSPP	M25x1.5	M25x1.5	Y3P3BB2F1T500007	Y3P3BB2F1T50000G

Because of permanent improvement of our products, drawings, descriptions, features used on these data sheets are for guidance only and can be modified without prior advice



# Medium size enclosure for immersion heater, finned heaters with external adjustment knob

Size(mm)	Volume(cm <sup>3</sup> )	Material	Protection grade		Model
<b>110 x 110 x 70</b>	<b>725</b>	<b>Aluminum</b>	<b>IP69K</b>	<b>IK10</b>	<b>Y3P4</b>

Suitable for
<input type="checkbox"/> Temperature sensor
<input checked="" type="checkbox"/> Immersion heater
<input checked="" type="checkbox"/> Finned heater
<input checked="" type="checkbox"/> Thermostat
<input type="checkbox"/> Level sensor
<input type="checkbox"/> Electronic board

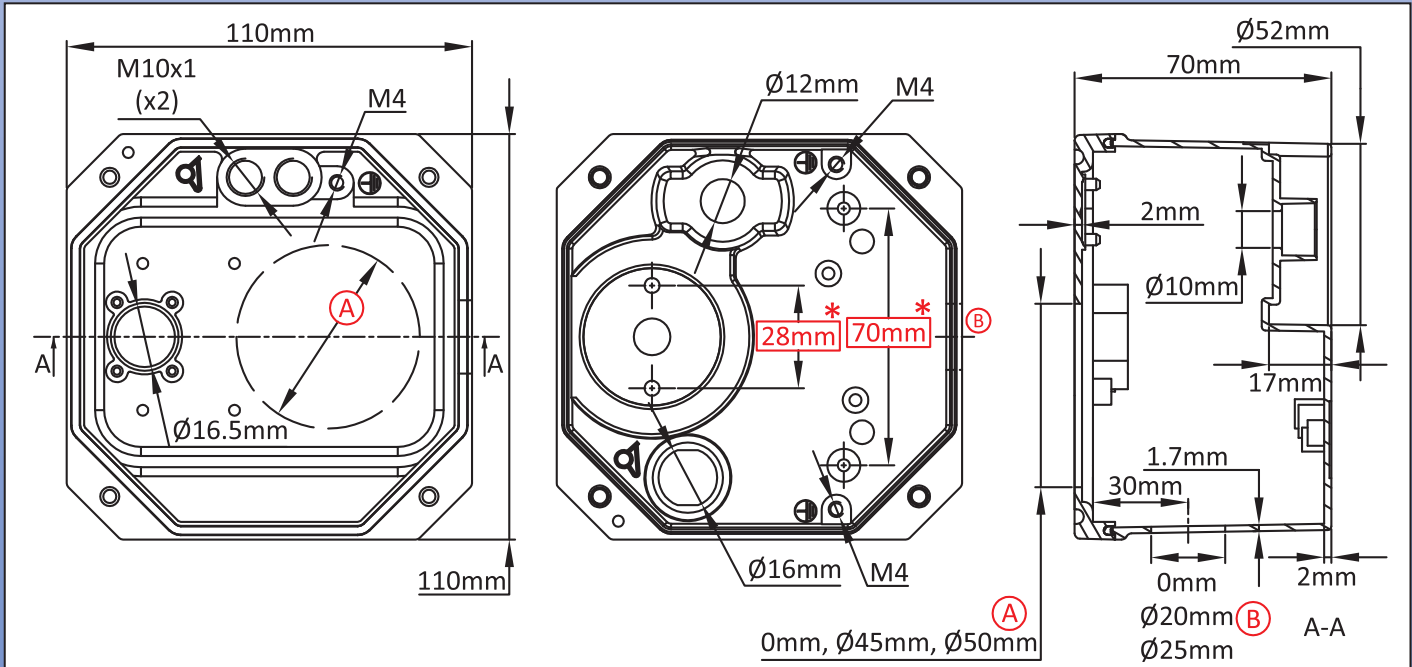
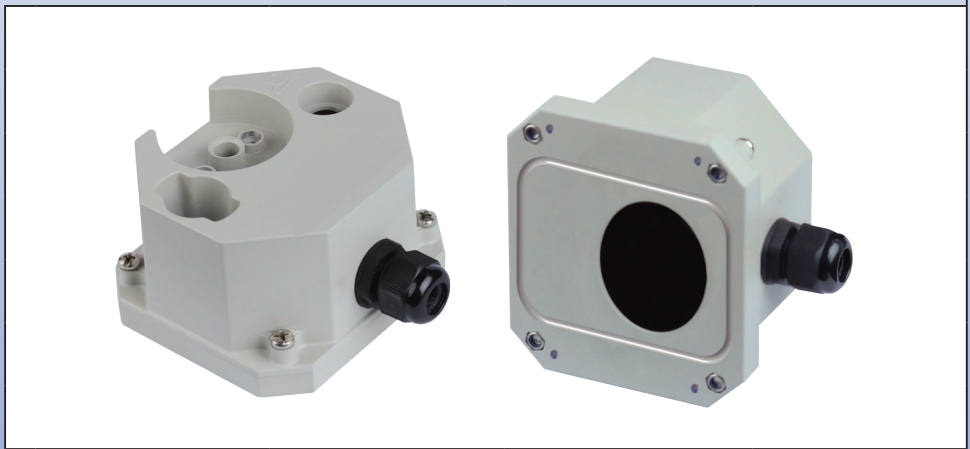

## Main references

(A)(mm)	(B)(mm)	Not painted	Painted
0	0	Y3P4000000000007	Y3P4000000000000G
0	20	Y3P4000012000007	Y3P400001200000G
0	25	Y3P4000012500007	Y3P400001250000G
45	0	Y3P4450000000007	Y3P445000000000G
45	20	Y3P4450012000007	Y3P445001200000G
45	25	Y3P4450012500007	Y3P445001250000G
50	0	Y3P4500000000007	Y3P450000000000G
50	20	Y3P4500012000007	Y3P450001200000G
50	25	Y3P4500012500007	Y3P450001250000G

## Links

	Page (.pdf)
	Drawing 2D (.dwg)
	Drawing 3D (.stp)

Cable gland not included in these reference, consult us if you want them.

Red dimensions inside rectangular frames are used for accessories assembly.

Because of permanent improvement of our products, drawings, descriptions, features used on these data sheets are for guidance only and can be modified without prior advice

# Large size enclosure for immersion heater, finned heaters or controls

Size(mm)	Volume(cm <sup>3</sup> )	Material	Protection grade		Model
92 x 124 x 159	1790	Aluminum	IP69K	IK10	<b>Y3P5</b> (P1)

### Suitable for

- Temperature sensor
- Immersion heater
- Finned heater
- Thermostat
- Level sensor
- Electronic board

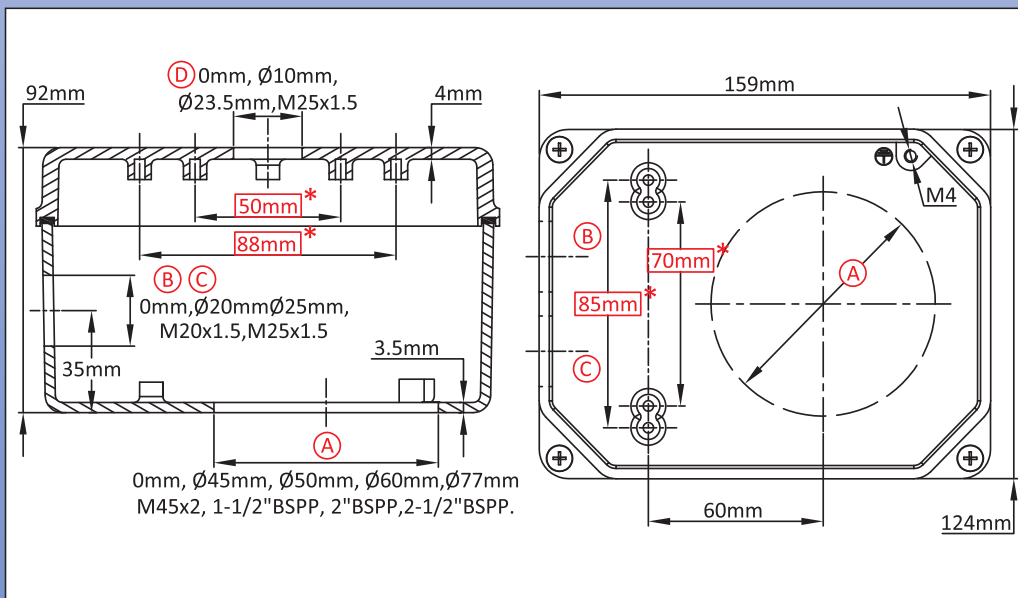

### Links



Page  
(.pdf)



Drawing 2D  
(.dwg)



Drawing 3D  
(.stp)

### Main references

A (mm)	B (mm)	C (mm)	D (mm)	Not painted	Painted	A (mm)	B (mm)	C (mm)	D (mm)	Not painted	Painted
0	0	0	0	Y3P5000000000007	Y3P500000000000G	0	M25x1.5	M25x1.5	10	Y3P5000A2T500007	Y3P5000A2T50000G
0	0	0	10	Y3P5000A00000007	Y3P5000A0000000G	0	M25x1.5	M25x1.5	23.5	Y3P5000D2T500007	Y3P5000D2T50000G
0	0	0	23.5	Y3P5000D00000007	Y3P5000D0000000G	0	M25x1.5	M25x1.5	M25x1.5	Y3P5000F2T500007	Y3P5000F2T50000G
0	0	0	M25x1.5	Y3P5000F00000007	Y3P5000F0000000G	45	0	0	0	Y3P5450000000007	Y3P545000000000G
0	20	20	0	Y3P5000D22000007	Y3P5000D2200000G	45	0	0	10	Y3P5450A00000007	Y3P5450A0000000G
0	20	20	10	Y3P5000A22000007	Y3P5000A2200000G	45	0	0	23.5	Y3P5450D00000007	Y3P5450D0000000G
0	20	20	23.5	Y3P5000D22000007	Y3P5000D2200000G	45	0	0	M25x1.5	Y3P5450F00000007	Y3P5450F0000000G
0	20	20	M25x1.5	Y3P5000F22000007	Y3P5000F2200000G	45	20	20	0	Y3P5450D22000007	Y3P5450D2200000G
0	25	25	0	Y3P5000D22500007	Y3P5000D2250000G	45	20	20	10	Y3P5450A22000007	Y3P5450A2200000G
0	25	25	10	Y3P5000A22500007	Y3P5000A2250000G	45	20	20	23.5	Y3P5450D22000007	Y3P5450D2200000G
0	25	25	23.5	Y3P5000D22500007	Y3P5000D2250000G	45	20	20	M25x1.5	Y3P5450F22000007	Y3P5450F2200000G
0	25	25	M25x1.5	Y3P5000F22500007	Y3P5000F2250000G	45	25	25	0	Y3P5450D22500007	Y3P5450D2250000G
0	M20x1.5	M20x1.5	0	Y3P5000D2T000007	Y3P5000D2T00000G	45	25	25	10	Y3P5450A22500007	Y3P5450A2250000G
0	M20x1.5	M20x1.5	10	Y3P5000A2T000007	Y3P5000A2T00000G	45	25	25	23.5	Y3P5450D22500007	Y3P5450D2250000G
0	M20x1.5	M20x1.5	23.5	Y3P5000D2T000007	Y3P5000D2T00000G	45	25	25	M25x1.5	Y3P5450F22500007	Y3P5450F2250000G
0	M20x1.5	M20x1.5	M25x1.5	Y3P5000F2T000007	Y3P5000F2T00000G	45	M20x1.5	M20x1.5	0	Y3P5450D2T000007	Y3P5450D2T00000G
0	M25x1.5	M25x1.5	0	Y3P5000D2T500007	Y3P5000D2T50000G	45	M20x1.5	M20x1.5	10	Y3P5450A2T000007	Y3P5450A2T00000G

Cable gland not included in these reference, consult us if you want them.

Red dimensions inside rectangular frames are used for accessories assembly.

# Large size enclosure for immersion heater, finned heaters or controls

**Y3P5**  
**(P2)**

Because of permanent improvement of our products, drawings, descriptions, features used on these data sheets are for guidance only and can be modified without prior advice

A (mm)	B (mm)	C (mm)	D (mm)	Not painted	Painted	A (mm)	B (mm)	C (mm)	D (mm)	Not painted	Painted
45	M20x1.5	M20x1.5	23.5	Y3P5450D2T000007	Y3P5450D2T00000G	M45x2	20	20	M25x1.5	Y3P5M45F22000007	Y3P5M45F2200000G
45	M20x1.5	M20x1.5	M25x1.5	Y3P5450F2T000007	Y3P5450F2T00000G	M45x2	25	25	0	Y3P5M450225000007	Y3P5M45022500000G
45	M25x1.5	M25x1.5	0	Y3P545002T500007	Y3P545002T50000G	M45x2	25	25	10	Y3P5M45A225000007	Y3P5M45A22500000G
45	M25x1.5	M25x1.5	10	Y3P5450A2T500007	Y3P5450A2T50000G	M45x2	25	25	23.5	Y3P5M45D225000007	Y3P5M45D22500000G
45	M25x1.5	M25x1.5	23.5	Y3P5450D2T500007	Y3P5450D2T50000G	M45x2	25	25	M25x1.5	Y3P5M45F225000007	Y3P5M45F22500000G
45	M25x1.5	M25x1.5	M25x1.5	Y3P5450F2T500007	Y3P5450F2T50000G	M45x2	M20x1.5	M20x1.5	0	Y3P5M4502T000007	Y3P5M4502T00000G
50	0	0	0	Y3P55000000000007	Y3P5500000000000G	M45x2	M20x1.5	M20x1.5	10	Y3P5M45A2T000007	Y3P5M45A2T00000G
50	0	0	10	Y3P5500A00000007	Y3P5500A00000000G	M45x2	M20x1.5	M20x1.5	23.5	Y3P5M45D2T000007	Y3P5M45D2T00000G
50	0	0	23.5	Y3P5500D00000007	Y3P5500D00000000G	M45x2	M20x1.5	M20x1.5	M25x1.5	Y3P5M45F2T000007	Y3P5M45F2T00000G
50	0	0	M25x1.5	Y3P5500F00000007	Y3P5500F00000000G	M45x2	M25x1.5	M25x1.5	0	Y3P5M4502T500007	Y3P5M4502T50000G
50	20	20	0	Y3P5500022000007	Y3P550002200000G	M45x2	M25x1.5	M25x1.5	10	Y3P5M45A2T500007	Y3P5M45A2T50000G
50	20	20	10	Y3P5500A22000007	Y3P5500A2200000G	M45x2	M25x1.5	M25x1.5	23.5	Y3P5M45D2T500007	Y3P5M45D2T50000G
50	20	20	23.5	Y3P5500D22000007	Y3P5500D2200000G	M45x2	M25x1.5	M25x1.5	M25x1.5	Y3P5M45F2T500007	Y3P5M45F2T50000G
50	20	20	M25x1.5	Y3P5500F22000007	Y3P5500F2200000G	1½" BSPP	0	0	0	Y3P5BA2000000007	Y3P5BA200000000G
50	25	25	0	Y3P5500022500007	Y3P550002250000G	1½" BSPP	0	0	10	Y3P5BA2A00000007	Y3P5BA2A00000000G
50	25	25	10	Y3P5500A22500007	Y3P5500A2250000G	1½" BSPP	0	0	23.5	Y3P5BA2D00000007	Y3P5BA2D00000000G
50	25	25	23.5	Y3P5500D22500007	Y3P5500D2250000G	1½" BSPP	0	0	M25x1.5	Y3P5BA2F00000007	Y3P5BA2F00000000G
50	25	25	M25x1.5	Y3P5500F22500007	Y3P5500F2250000G	1½" BSPP	20	20	0	Y3P5BA2022000007	Y3P5BA202200000G
50	M20x1.5	M20x1.5	0	Y3P550002T000007	Y3P550002T00000G	1½" BSPP	20	20	10	Y3P5BA2A22000007	Y3P5BA2A22000000G
50	M20x1.5	M20x1.5	10	Y3P5500A2T000007	Y3P5500A2T00000G	1½" BSPP	20	20	23.5	Y3P5BA2D22000007	Y3P5BA2D22000000G
50	M20x1.5	M20x1.5	23.5	Y3P5500D2T000007	Y3P5500D2T00000G	1½" BSPP	20	20	M25x1.5	Y3P5BA2F22000007	Y3P5BA2F22000000G
50	M20x1.5	M20x1.5	M25x1.5	Y3P5500F2T000007	Y3P5500F2T00000G	1½" BSPP	25	25	0	Y3P5BA2022500007	Y3P5BA202250000G
50	M25x1.5	M25x1.5	0	Y3P550002T500007	Y3P550002T50000G	1½" BSPP	25	25	10	Y3P5BA2A22500007	Y3P5BA2A22500000G
50	M25x1.5	M25x1.5	10	Y3P5500A2T500007	Y3P5500A2T50000G	1½" BSPP	25	25	23.5	Y3P5BA2D22500007	Y3P5BA2D22500000G
50	M25x1.5	M25x1.5	23.5	Y3P5500D2T500007	Y3P5500D2T50000G	1½" BSPP	25	25	M25x1.5	Y3P5BA2F22500007	Y3P5BA2F22500000G
50	M25x1.5	M25x1.5	M25x1.5	Y3P5500F2T500007	Y3P5500F2T50000G	1½" BSPP	M20x1.5	M20x1.5	0	Y3P5BA202T000007	Y3P5BA202T00000G
60	0	0	0	Y3P56000000000007	Y3P5600000000000G	1½" BSPP	M20x1.5	M20x1.5	10	Y3P5BA2A2T000007	Y3P5BA2A2T00000G
60	0	0	10	Y3P5600A00000007	Y3P5600A00000000G	1½" BSPP	M20x1.5	M20x1.5	23.5	Y3P5BA2D2T000007	Y3P5BA2D2T00000G
60	0	0	23.5	Y3P5600D00000007	Y3P5600D00000000G	1½" BSPP	M20x1.5	M20x1.5	M25x1.5	Y3P5BA2F2T000007	Y3P5BA2F2T00000G
60	0	0	M25x1.5	Y3P5600F00000007	Y3P5600F00000000G	1½" BSPP	M25x1.5	M25x1.5	0	Y3P5BA202T500007	Y3P5BA202T50000G
60	20	20	0	Y3P5600022000007	Y3P560002200000G	1½" BSPP	M25x1.5	M25x1.5	10	Y3P5BA2A2T500007	Y3P5BA2A2T50000G
60	20	20	10	Y3P5600A22000007	Y3P5600A2200000G	1½" BSPP	M25x1.5	M25x1.5	23.5	Y3P5BA2D2T500007	Y3P5BA2D2T50000G
60	20	20	23.5	Y3P5600D22000007	Y3P5600D2200000G	1½" BSPP	M25x1.5	M25x1.5	M25x1.5	Y3P5BA2F2T500007	Y3P5BA2F2T50000G
60	20	20	M25x1.5	Y3P5600F22000007	Y3P5600F2200000G	2" BSPP	0	0	0	Y3P5BB2000000007	Y3P5BB200000000G
60	25	25	0	Y3P5600022500007	Y3P560002250000G	2" BSPP	0	0	10	Y3P5BB2A00000007	Y3P5BB2A00000000G
60	25	25	10	Y3P5600A22500007	Y3P5600A2250000G	2" BSPP	0	0	23.5	Y3P5BB2D00000007	Y3P5BB2D00000000G
60	25	25	23.5	Y3P5600D22500007	Y3P5600D2250000G	2" BSPP	0	0	M25x1.5	Y3P5BB2F00000007	Y3P5BB2F00000000G
60	25	25	M25x1.5	Y3P5600F22500007	Y3P5600F2250000G	2" BSPP	20	20	0	Y3P5BB2022000007	Y3P5BB202200000G
60	M20x1.5	M20x1.5	0	Y3P560002T000007	Y3P560002T00000G	2" BSPP	20	20	10	Y3P5BB2A22000007	Y3P5BB2A22000000G
60	M20x1.5	M20x1.5	10	Y3P5600A2T000007	Y3P5600A2T00000G	2" BSPP	20	20	23.5	Y3P5BB2D22000007	Y3P5BB2D22000000G
60	M20x1.5	M20x1.5	23.5	Y3P5600D2T000007	Y3P5600D2T00000G	2" BSPP	20	20	M25x1.5	Y3P5BB2F22000007	Y3P5BB2F22000000G
60	M20x1.5	M20x1.5	M25x1.5	Y3P5600F2T000007	Y3P5600F2T00000G	2" BSPP	25	25	0	Y3P5BB2022500007	Y3P5BB202250000G
60	M25x1.5	M25x1.5	0	Y3P560002T500007	Y3P560002T50000G	2" BSPP	25	25	10	Y3P5BB2A22500007	Y3P5BB2A22500000G
60	M25x1.5	M25x1.5	10	Y3P5600A2T500007	Y3P5600A2T50000G	2" BSPP	25	25	23.5	Y3P5BB2D22500007	Y3P5BB2D22500000G
60	M25x1.5	M25x1.5	23.5	Y3P5600D2T500007	Y3P5600D2T50000G	2" BSPP	25	25	M25x1.5	Y3P5BB2F22500007	Y3P5BB2F22500000G
60	M25x1.5	M25x1.5	M25x1.5	Y3P5600F2T500007	Y3P5600F2T50000G	2" BSPP	M20x1.5	M20x1.5	0	Y3P5BB202T000007	Y3P5BB202T00000G
77	0	0	0	Y3P57700000000007	Y3P5770000000000G	2" BSPP	M20x1.5	M20x1.5	10	Y3P5BB2A2T000007	Y3P5BB2A2T00000G
77	0	0	10	Y3P5770A00000007	Y3P5770A00000000G	2" BSPP	M20x1.5	M20x1.5	23.5	Y3P5BB2D2T000007	Y3P5BB2D2T00000G
77	0	0	23.5	Y3P5770D00000007	Y3P5770D00000000G	2" BSPP	M20x1.5	M20x1.5	M25x1.5	Y3P5BB2F2T000007	Y3P5BB2F2T00000G
77	0	0	M25x1.5	Y3P5770F00000007	Y3P5770F00000000G	2" BSPP	M25x1.5	M25x1.5	0	Y3P5BB202T500007	Y3P5BB202T50000G
77	20	20	0	Y3P5770022000007	Y3P577002200000G	2" BSPP	M25x1.5	M25x1.5	10	Y3P5BB2A2T500007	Y3P5BB2A2T50000G
77	20	20	10	Y3P5770A22000007	Y3P5770A2200000G	2" BSPP	M25x1.5	M25x1.5	23.5	Y3P5BB2D2T500007	Y3P5BB2D2T50000G
77	20	20	23.5	Y3P5770D22000007	Y3P5770D2200000G	2" BSPP	M25x1.5	M25x1.5	M25x1.5	Y3P5BB2F2T500007	Y3P5BB2F2T50000G
77	20	20	M25x1.5	Y3P5770F22000007	Y3P5770F2200000G	2½" BSPP	0	0	0	Y3P5BC2000000007	Y3P5BC200000000G
77	25	25	0	Y3P5770022500007	Y3P577002250000G	2½" BSPP	0	0	10	Y3P5BC2A00000007	Y3P5BC2A00000000G
77	25	25	10	Y3P5770A22500007	Y3P5770A2250000G	2½" BSPP	0	0	23.5	Y3P5BC2D00000007	Y3P5BC2D00000000G
77	25	25	23.5	Y3P5770D22500007	Y3P5770D2250000G	2½" BSPP	0	0	M25x1.5	Y3P5BC2F00000007	Y3P5BC2F00000000G
77	25	25	M25x1.5	Y3P5770F22500007	Y3P5770F2250000G	2½" BSPP	20	20	0	Y3P5BC2022000007	Y3P5BC202200000G
77	M20x1.5	M20x1.5	0	Y3P577002T000007	Y3P577002T00000G	2½" BSPP	20	20	10	Y3P5BC2A22000007	Y3P5BC2A22000000G
77	M20x1.5	M20x1.5	10	Y3P5770A2T000007	Y3P5770A2T00000G	2½" BSPP	20	20	23.5	Y3P5BC2D22000007	Y3P5BC2D22000000G
77	M20x1.5	M20x1.5	23.5	Y3P5770D2T000007	Y3P5770D2T00000G	2½" BSPP	20	20	M25x1.5	Y3P5BC2F22000007	Y3P5BC2F22000000G
77	M20x1.5	M20x1.5	M25x1.5	Y3P5770F2T000007	Y3P5770F2T00000G	2½" BSPP	25	25	0	Y3P5BC2022500007	Y3P5BC202250000G
77	M25x1.5	M25x1.5	0	Y3P577002T500007	Y3P577002T50000G	2½" BSPP	25	25	10	Y3P5BC2A22500007	Y3P5BC2A22500000G
77	M25x1.5	M25x1.5	10	Y3P5770A2T500007	Y3P5770A2T50000G	2½" BSPP	25	25	23.5	Y3P5BC2D22500007	Y3P5BC2D22500000G
77	M25x1.5	M25x1.5	23.5	Y3P5770D2T500007	Y3P5770D2T50000G	2½" BSPP	25	25	M25x1.5	Y3P5BC2F22500007	Y3P5BC2F22500000G
77	M25x1.5	M25x1.5	M25x1.5	Y3P5770F2T500007	Y3P5770F2T50000G	2½" BSPP	M20x1.5	M20x1.5	0	Y3P5BC202T000007	Y3P5BC202T00000G
M45x2	0	0	0	Y3P5M450000000007	Y3P5M45000000000G	2½" BSPP	M20x1.5	M20x1.5	10	Y3P5BC2A2T000007	Y3P5BC2A2T00000G
M45x2	0	0	10	Y3P5M45A00000007	Y3P5M45A00000000G	2½" BSPP	M20x1.5	M20x1.5	23.5	Y3P5BC2D2T000007	Y3P5BC2D2T00000G
M45x2	0	0	23.5	Y3P5M45D00000007	Y3P5M45D00000000G	2½" BSPP	M20x1.5	M20x1.5	M25x1.5	Y3P5BC2F2T000007	Y3P5BC2F2T00000G
M45x2	0	0	M25x1.5	Y3P5M45F00000007	Y3P5M45F00000000G	2½" BSPP	M25x1.5	M25x1.5	0	Y3P5BC202T500007	Y3P5BC202T50000G
M45x2	20	20	0	Y3P5M45022000007	Y3P5M4502200000G	2½" BSPP	M25x1.5	M25x1.5	10	Y3P5BC2A2T500007	Y3P5BC2A2T50000G
M45x2	20	20	10	Y3P5M45A22000007	Y3P5M45A2200000G	2½" BSPP	M25x1.5	M25x1.5	23.5	Y3P5BC2D2T500007	Y3P5BC2D2T50000G
M45x2	20	20	23.5	Y3P5M45D22000007	Y3P5M45D2200000G	2½" BSPP	M25x1.5	M25x1.5	M25x1.5	Y3P5BC2F2T500007	Y3P5BC2F2T50000G

# Large size enclosure for immersion heater, finned heaters with external adjustment knob

Size(mm)	Volume(cm <sup>3</sup> )	Material	Protection grade		Model
<b>89 x 124 x 155</b>	<b>1600</b>	<b>Aluminum</b>	<b>IP69K</b>	<b>IK10</b>	<b>Y3P6</b> <b>(P1)</b>

### Suitable for

- Temperature sensor
- Immersion heater
- Finned heater
- Thermostat
- Level sensor
- Electronic board

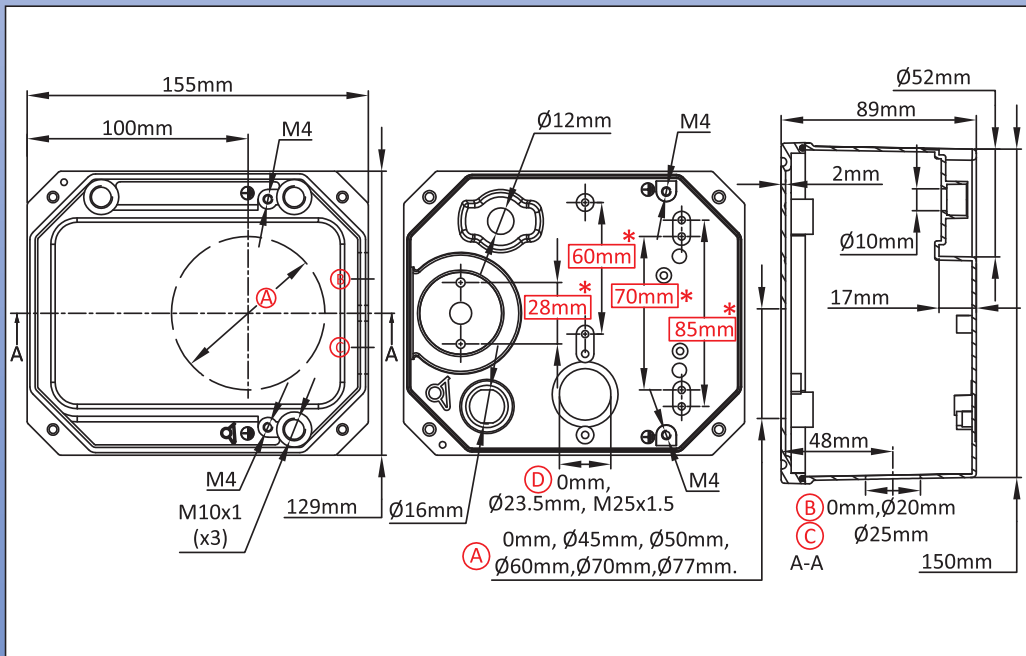
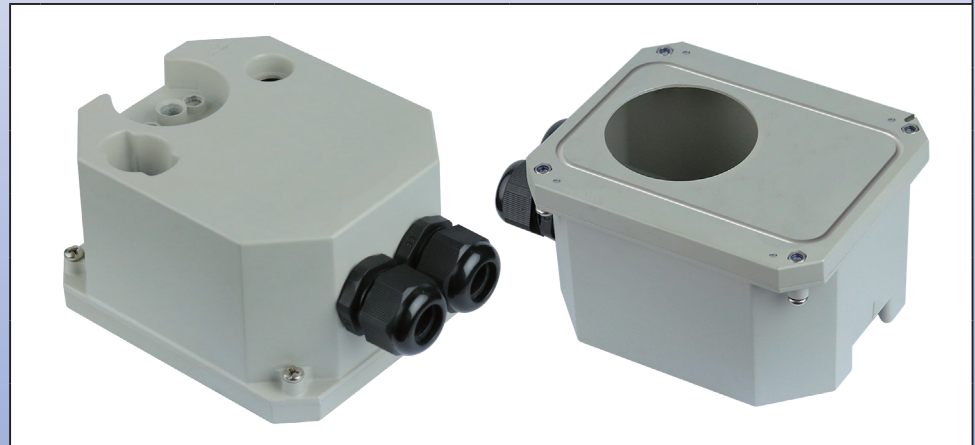

### Links



Page  
(.pdf)



Drawing 2D  
(.dwg)



Drawing 3D  
(.stp)

### Main references

(A) (mm)	(B) (mm)	(C) (mm)	(D) (mm)	Not painted	Painted	(A) (mm)	(B) (mm)	(C) (mm)	(D) (mm)	Not painted	Painted
0	0	0	0	Y3P6000000000007	Y3P6000000000000G	0	25	0	0	Y3P6000012500007	Y3P600001250000G
0	0	0	23.5	Y3P6000D00000007	Y3P6000D0000000G	0	25	0	23.5	Y3P6000D12500007	Y3P6000D1250000G
0	0	0	M25x1.5	Y3P6000F00000007	Y3P6000F0000000G	0	25	0	M25x1.5	Y3P6000F12500007	Y3P6000F1250000G
0	20	0	0	Y3P6000012000007	Y3P600001200000G	0	25	25	0	Y3P6000022500007	Y3P600002250000G
0	20	0	23.5	Y3P6000D12000007	Y3P6000D1200000G	0	25	25	23.5	Y3P6000D22500007	Y3P6000D2250000G
0	20	0	M25x1.5	Y3P6000F12000007	Y3P6000F1200000G	0	25	25	M25x1.5	Y3P6000F22500007	Y3P6000F2250000G
0	20	20	0	Y3P6000022000007	Y3P600002200000G	45	0	0	0	Y3P6450000000007	Y3P645000000000G
0	20	20	23.5	Y3P6000D22000007	Y3P6000D2200000G	45	0	0	23.5	Y3P6450D00000007	Y3P6450D0000000G
0	20	20	M25x1.5	Y3P6000F22000007	Y3P6000F2200000G	45	0	0	M25x1.5	Y3P6450F00000007	Y3P6450F0000000G

Cable gland not included in these reference, consult us if you want them.

Red dimensions inside rectangular frames are used for accessories assembly.

# Large size enclosure for immersion heater, finned heaters with external adjustment knob

**Y3P6  
(P2)**

(A) (mm)	(B) (mm)	(C) (mm)	(D) (mm)	Not painted	Painted	(A) (mm)	(B) (mm)	(C) (mm)	(D) (mm)	Not painted	Painted
45	20	0	0	Y3P6450012000007	Y3P645001200000G	60	25	0	0	Y3P6600012500007	Y3P660001250000G
45	20	0	23.5	Y3P6450D12000007	Y3P6450D1200000G	60	25	0	23.5	Y3P6600D12500007	Y3P6600D1250000G
45	20	0	M25×1.5	Y3P6450F12000007	Y3P6450F1200000G	60	25	0	M25×1.5	Y3P6600F12500007	Y3P6600F1250000G
45	20	20	0	Y3P6450022000007	Y3P645002200000G	60	25	25	0	Y3P6600022500007	Y3P660002250000G
45	20	20	23.5	Y3P6450D22000007	Y3P6450D2200000G	60	25	25	23.5	Y3P6600D22500007	Y3P6600D2250000G
45	20	20	M25×1.5	Y3P6450F22000007	Y3P6450F2200000G	60	25	25	M25×1.5	Y3P6600F22500007	Y3P6600F2250000G
45	25	0	0	Y3P6450012500007	Y3P645001250000G	70	0	0	0	Y3P6700000000007	Y3P670000000000G
45	25	0	23.5	Y3P6450D12500007	Y3P6450D1250000G	70	0	0	23.5	Y3P6700D00000007	Y3P6700D0000000G
45	25	0	M25×1.5	Y3P6450F12500007	Y3P6450F1250000G	70	0	0	M25×1.5	Y3P6700F00000007	Y3P6700F0000000G
45	25	25	0	Y3P6450022500007	Y3P645002250000G	70	20	0	0	Y3P6700012000007	Y3P670001200000G
45	25	25	23.5	Y3P6450D22500007	Y3P6450D2250000G	70	20	0	23.5	Y3P6700D12000007	Y3P6700D1200000G
45	25	25	M25×1.5	Y3P6450F22500007	Y3P6450F2250000G	70	20	0	M25×1.5	Y3P6700F12000007	Y3P6700F1200000G
50	0	0	0	Y3P6500000000007	Y3P650000000000G	70	20	20	0	Y3P6700022000007	Y3P670002200000G
50	0	0	23.5	Y3P6500D00000007	Y3P6500D0000000G	70	20	20	23.5	Y3P6700D22000007	Y3P6700D2200000G
50	0	0	M25×1.5	Y3P6500F00000007	Y3P6500F0000000G	70	20	20	M25×1.5	Y3P6700F22000007	Y3P6700F2200000G
50	20	0	0	Y3P6500012000007	Y3P650001200000G	70	25	0	0	Y3P6700012500007	Y3P670001250000G
50	20	0	23.5	Y3P6500D12000007	Y3P6500D1200000G	70	25	0	23.5	Y3P6700D12500007	Y3P6700D1250000G
50	20	0	M25×1.5	Y3P6500F12000007	Y3P6500F1200000G	70	25	0	M25×1.5	Y3P6700F12500007	Y3P6700F1250000G
50	20	20	0	Y3P6500022000007	Y3P650002200000G	70	25	25	0	Y3P6700022500007	Y3P670002250000G
50	20	20	23.5	Y3P6500D22000007	Y3P6500D2200000G	70	25	25	23.5	Y3P6700D22500007	Y3P6700D2250000G
50	20	20	M25×1.5	Y3P6500F22000007	Y3P6500F2200000G	70	25	25	M25×1.5	Y3P6700F22500007	Y3P6700F2250000G
50	25	0	0	Y3P6500012500007	Y3P650001250000G	77	0	0	0	Y3P6770000000007	Y3P677000000000G
50	25	0	23.5	Y3P6500D12500007	Y3P6500D1250000G	77	0	0	23.5	Y3P6770D00000007	Y3P6770D0000000G
50	25	0	M25×1.5	Y3P6500F12500007	Y3P6500F1250000G	77	0	0	M25×1.5	Y3P6770F00000007	Y3P6770F0000000G
50	25	25	0	Y3P6500022500007	Y3P650002250000G	77	20	0	0	Y3P6770012000007	Y3P677001200000G
50	25	25	23.5	Y3P6500D22500007	Y3P6500D2250000G	77	20	0	23.5	Y3P6770D12000007	Y3P6770D1200000G
50	25	25	M25×1.5	Y3P6500F22500007	Y3P6500F2250000G	77	20	0	M25×1.5	Y3P6770F12000007	Y3P6770F1200000G
60	0	0	0	Y3P6600000000007	Y3P660000000000G	77	20	20	0	Y3P6770022000007	Y3P677002200000G
60	0	0	23.5	Y3P6600D00000007	Y3P6600D0000000G	77	20	20	23.5	Y3P6770D22000007	Y3P6770D2200000G
60	0	0	M25×1.5	Y3P6600F00000007	Y3P6600F0000000G	77	20	20	M25×1.5	Y3P6770F22000007	Y3P6770F2200000G
60	20	0	0	Y3P6600012000007	Y3P660001200000G	77	25	0	0	Y3P6770012500007	Y3P677001250000G
60	20	0	23.5	Y3P6600D12000007	Y3P6600D1200000G	77	25	0	23.5	Y3P6770D12500007	Y3P6770D1250000G
60	20	0	M25×1.5	Y3P6600F12000007	Y3P6600F1200000G	77	25	0	M25×1.5	Y3P6770F12500007	Y3P6770F1250000G
60	20	20	0	Y3P6600022000007	Y3P660002200000G	77	25	25	0	Y3P6770022500007	Y3P677002250000G
60	20	20	23.5	Y3P6600D22000007	Y3P6600D2200000G	77	25	25	23.5	Y3P6770D22500007	Y3P6770D2250000G
60	20	20	M25×1.5	Y3P6600F22000007	Y3P6600F2200000G	77	25	25	M25×1.5	Y3P6770F22500007	Y3P6770F2250000G

Because of permanent improvement of our products, drawings, descriptions, features used on these data sheets are for guidance only and can be modified without prior advice

# Enclosure with aluminum body, black or transparent polycarbonate cover, for immersion heater or solid state relays (SSR) controls

Size(mm)	Volume(cm <sup>3</sup> )	Material	Protection grade		Model
<b>81 x 132 x 182</b>	<b>1870</b>	<b>Aluminum + Polycarbonate</b>	<b>IP69K</b>	<b>IK10</b>	<b>Y3H1</b>

- Suitable for**
- Temperature sensor
  - Immersion heater
  - Finned heater
  - Thermostat
  - Level sensor
  - Electronic board

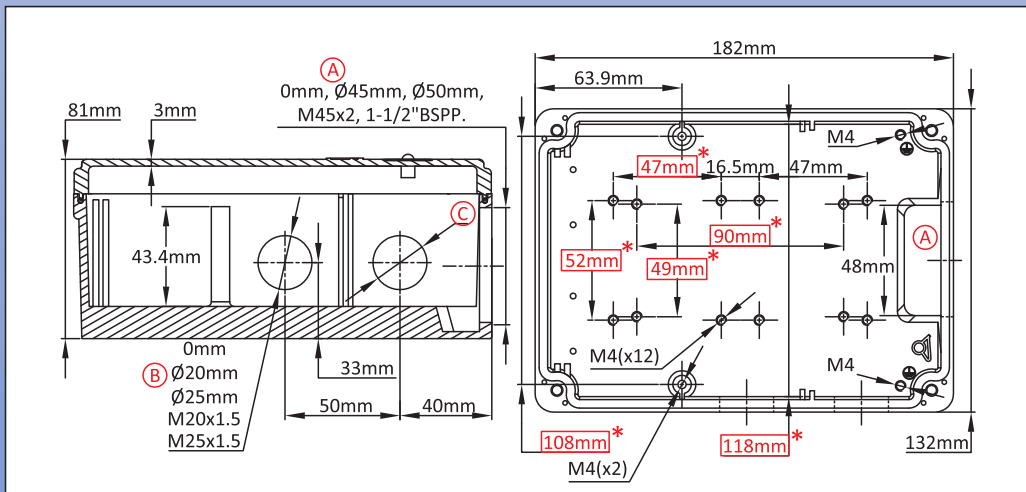

**Links**

Page  
(.pdf)

Drawing 2D  
(.dwg)

Drawing 3D  
(.stp)

### Main references

Ⓐ(mm)	Ⓑ(mm)	Ⓒ(mm)	Not painted	Painted	Ⓐ(mm)	Ⓑ(mm)	Ⓒ(mm)	Not painted	Painted
0	0	0	Y3H1000000000007	Y3H100000000000G	50	M20x1.5	0	Y3H150001T000007	Y3H150001T00000G
0	20	0	Y3H1000012000007	Y3H100001200000G	50	M20x1.5	M20x1.5	Y3H150002T000007	Y3H150002T00000G
0	20	20	Y3H1000022000007	Y3H100002200000G	50	M25x1.5	0	Y3H150001T500007	Y3H150001T50000G
0	25	0	Y3H1000012500007	Y3H100001250000G	50	M25x1.5	M25x1.5	Y3H150002T500007	Y3H150002T50000G
0	25	25	Y3H1000022500007	Y3H100002250000G	M45x2	0	0	Y3H1M45000000007	Y3H1M4500000000G
0	M20x1.5	0	Y3H100001T000007	Y3H100001T00000G	M45x2	20	0	Y3H1M45012000007	Y3H1M4501200000G
0	M20x1.5	M20x1.5	Y3H100002T000007	Y3H100002T00000G	M45x2	20	20	Y3H1M45022000007	Y3H1M4502200000G
0	M25x1.5	0	Y3H100001T500007	Y3H100001T50000G	M45x2	25	0	Y3H1M45012500007	Y3H1M4501250000G
0	M25x1.5	M25x1.5	Y3H100002T500007	Y3H100002T50000G	M45x2	25	25	Y3H1M45022500007	Y3H1M4502250000G
45	0	0	Y3H1450000000007	Y3H145000000000G	M45x2	M20x1.5	0	Y3H1M4501T000007	Y3H1M4501T00000G
45	20	0	Y3H1450012000007	Y3H145001200000G	M45x2	M20x1.5	M20x1.5	Y3H1M4502T000007	Y3H1M4502T00000G
45	20	20	Y3H1450022000007	Y3H145002200000G	M45x2	M25x1.5	0	Y3H1M4501T500007	Y3H1M4501T50000G
45	25	0	Y3H1450012500007	Y3H145001250000G	M45x2	M25x1.5	M25x1.5	Y3H1M4502T500007	Y3H1M4502T50000G
45	25	25	Y3H1450022500007	Y3H145002250000G	1½"BSPP	0	0	Y3H1BA20000000007	Y3H1BA2000000000G
45	M20x1.5	0	Y3H145001T000007	Y3H145001T00000G	1½"BSPP	20	0	Y3H1BA2012000007	Y3H1BA201200000G
45	M20x1.5	M20x1.5	Y3H145002T000007	Y3H145002T00000G	1½"BSPP	20	20	Y3H1BA2022000007	Y3H1BA202200000G
45	M25x1.5	0	Y3H145001T500007	Y3H145001T50000G	1½"BSPP	25	0	Y3H1BA2012500007	Y3H1BA201250000G
45	M25x1.5	M25x1.5	Y3H145002T500007	Y3H145002T50000G	1½"BSPP	25	25	Y3H1BA2022500007	Y3H1BA202250000G
50	0	0	Y3H1500000000007	Y3H150000000000G	1½"BSPP	M20x1.5	0	Y3H1BA201T000007	Y3H1BA201T00000G
50	20	0	Y3H1500012000007	Y3H150001200000G	1½"BSPP	M20x1.5	M20x1.5	Y3H1BA202T000007	Y3H1BA202T00000G
50	20	20	Y3H1500022000007	Y3H150002200000G	1½"BSPP	M25x1.5	0	Y3H1BA201T500007	Y3H1BA201T50000G
50	25	0	Y3H1500012500007	Y3H150001250000G	1½"BSPP	M25x1.5	M25x1.5	Y3H1BA202T500007	Y3H1BA202T50000G
50	25	25	Y3H1500022500007	Y3H150002250000G					

Cable gland not included in these reference, consult us if you want them.

Red dimensions inside rectangular frames are used for accessories assembly.

# Enclosure with aluminum body, and plastic cover with transparent window, for immersion heater or solid state relays (SSR) controls

Size(mm)	Volume(cm <sup>3</sup> )	Material	Protection grade		Model
<b>95 x 132 x 182</b>	<b>2010</b>	<b>Aluminum + PA66 + Polycarbonate</b>	<b>IP69K</b>	<b>IK10</b>	<b>Y3H2</b>

Suitable for
<input type="checkbox"/> Temperature sensor
<input checked="" type="checkbox"/> Immersion heater
<input type="checkbox"/> Finned heater
<input checked="" type="checkbox"/> Thermostat
<input type="checkbox"/> Level sensor
<input type="checkbox"/> Electronic board

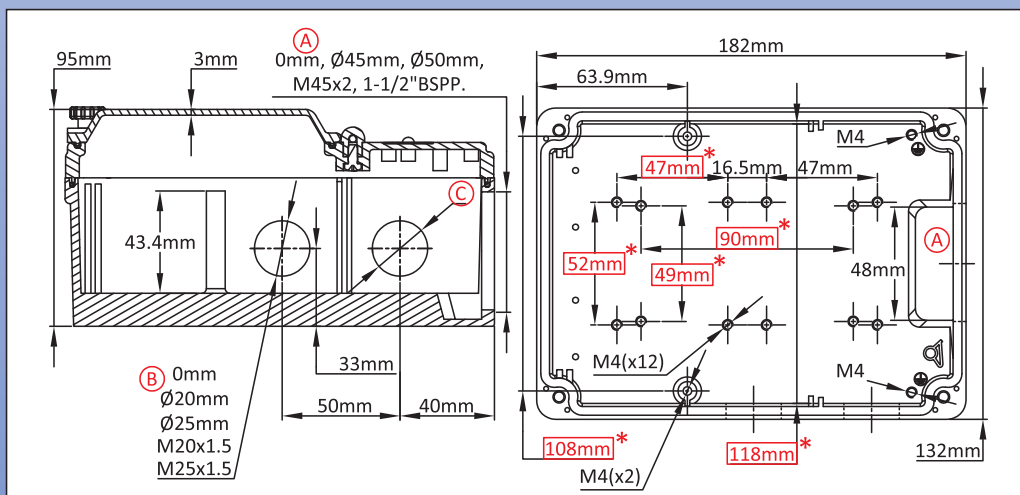

### Links

- [Page \(.pdf\)](#)
- [Drawing 2D \(.dwg\)](#)
- [Drawing 3D \(.stp\)](#)

### Main references

Ⓐ(mm)	Ⓑ(mm)	Ⓒ(mm)	Not painted	Painted	Ⓐ(mm)	Ⓑ(mm)	Ⓒ(mm)	Not painted	Painted
0	0	0	Y3H2000000000007	Y3H200000000000G	50	M20x1.5	0	Y3H250001T000007	Y3H250001T00000G
0	20	0	Y3H2000012000007	Y3H200001200000G	50	M20x1.5	M20x1.5	Y3H250002T000007	Y3H250002T00000G
0	20	20	Y3H2000022000007	Y3H200002200000G	50	M25x1.5	0	Y3H250001T500007	Y3H250001T50000G
0	25	0	Y3H2000012500007	Y3H200001250000G	50	M25x1.5	M25x1.5	Y3H250002T500007	Y3H250002T50000G
0	25	25	Y3H2000022500007	Y3H200002250000G	M45x2	0	0	Y3H2M45000000007	Y3H2M4500000000G
0	M20x1.5	0	Y3H200001T000007	Y3H200001T00000G	M45x2	20	0	Y3H2M45012000007	Y3H2M4501200000G
0	M20x1.5	M20x1.5	Y3H200002T000007	Y3H200002T00000G	M45x2	20	20	Y3H2M45022000007	Y3H2M4502200000G
0	M25x1.5	0	Y3H200001T500007	Y3H200001T50000G	M45x2	25	0	Y3H2M45012500007	Y3H2M4501250000G
0	M25x1.5	M25x1.5	Y3H200002T500007	Y3H200002T50000G	M45x2	25	25	Y3H2M45022500007	Y3H2M4502250000G
45	0	0	Y3H2450000000007	Y3H245000000000G	M45x2	M20x1.5	0	Y3H2M4501T000007	Y3H2M4501T00000G
45	20	0	Y3H2450012000007	Y3H245001200000G	M45x2	M20x1.5	M20x1.5	Y3H2M4502T000007	Y3H2M4502T00000G
45	20	20	Y3H2450022000007	Y3H245002200000G	M45x2	M25x1.5	0	Y3H2M4501T500007	Y3H2M4501T50000G
45	25	0	Y3H2450012500007	Y3H245001250000G	M45x2	M25x1.5	M25x1.5	Y3H2M4502T500007	Y3H2M4502T50000G
45	25	25	Y3H2450022500007	Y3H245002250000G	1½\"/>				

Cable gland not included in these reference, consult us if you want them.

Red dimensions inside rectangular frames are used for accessories assembly.

Because of permanent improvement of our products, drawings, descriptions, features used on these data sheets are for guidance only and can be modified without prior advice

# All aluminum enclosure, for immersion heater or solid state relays (SSR) controls

Size(mm)	Volume(cm <sup>3</sup> )	Material	Protection grade		Model
<b>96 x 132 x 182</b>	<b>2050</b>	<b>Aluminum</b>	<b>IP69K</b>	<b>IK10</b>	<b>Y3H3</b>

Suitable for
<input type="checkbox"/> Temperature sensor
<input checked="" type="checkbox"/> Immersion heater
<input type="checkbox"/> Finned heater
<input checked="" type="checkbox"/> Thermostat
<input type="checkbox"/> Level sensor
<input type="checkbox"/> Electronic board

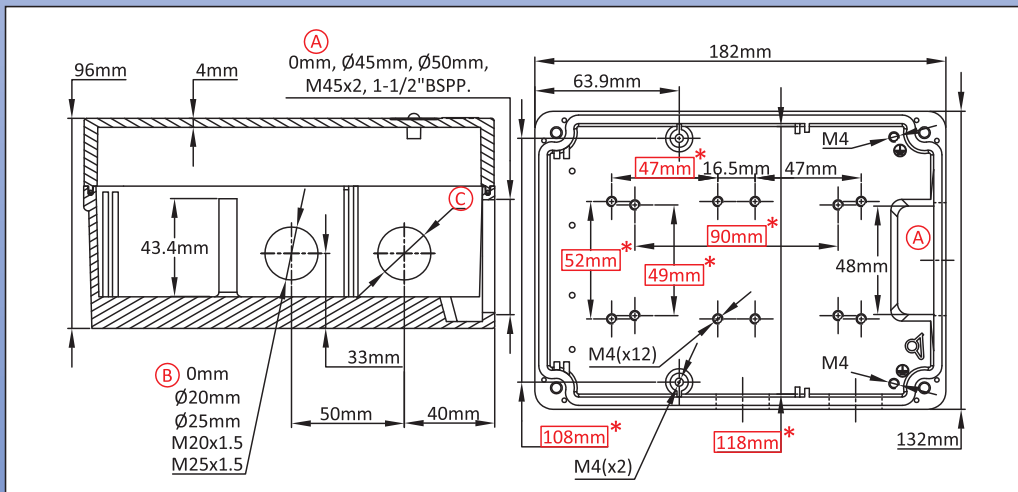

### Links

Page  
(.pdf)

Drawing 2D  
(.dwg)

Drawing 3D  
(.stp)

### Main references

Ⓐ(mm)	Ⓑ(mm)	Ⓒ(mm)	Not painted	Painted	Ⓐ(mm)	Ⓑ(mm)	Ⓒ(mm)	Not painted	Painted
0	0	0	Y3H3000000000007	Y3H3000000000000G	50	M20x1.5	0	Y3H350001T000007	Y3H350001T00000G
0	20	0	Y3H3000012000007	Y3H300001200000G	50	M20x1.5	M20x1.5	Y3H350002T000007	Y3H350002T00000G
0	20	20	Y3H3000022000007	Y3H300002200000G	50	M25x1.5	0	Y3H350001T500007	Y3H350001T50000G
0	25	0	Y3H3000012500007	Y3H300001250000G	50	M25x1.5	M25x1.5	Y3H350002T500007	Y3H350002T50000G
0	25	25	Y3H3000022500007	Y3H300002250000G	M45x2	0	0	Y3H3M45000000007	Y3H3M4500000000G
0	M20x1.5	0	Y3H300001T000007	Y3H300001T00000G	M45x2	20	0	Y3H3M45012000007	Y3H3M4501200000G
0	M20x1.5	M20x1.5	Y3H300002T000007	Y3H300002T00000G	M45x2	20	20	Y3H3M45022000007	Y3H3M4502200000G
0	M25x1.5	0	Y3H300001T500007	Y3H300001T50000G	M45x2	25	0	Y3H3M45012500007	Y3H3M4501250000G
0	M25x1.5	M25x1.5	Y3H300002T500007	Y3H300002T50000G	M45x2	25	25	Y3H3M45022500007	Y3H3M4502250000G
45	0	0	Y3H3450000000007	Y3H345000000000G	M45x2	M20x1.5	0	Y3H3M4501T000007	Y3H3M4501T00000G
45	20	0	Y3H3450012000007	Y3H345001200000G	M45x2	M20x1.5	M20x1.5	Y3H3M4502T000007	Y3H3M4502T00000G
45	20	20	Y3H3450022000007	Y3H345002200000G	M45x2	M25x1.5	0	Y3H3M4501T500007	Y3H3M4501T50000G
45	25	0	Y3H3450012500007	Y3H345001250000G	M45x2	M25x1.5	M25x1.5	Y3H3M4502T500007	Y3H3M4502T50000G
45	25	25	Y3H3450022500007	Y3H345002250000G	1/2"BSPP	0	0	Y3H3BA20000000007	Y3H3BA2000000000G
45	M20x1.5	0	Y3H345001T000007	Y3H345001T00000G	1/2"BSPP	20	0	Y3H3BA2012000007	Y3H3BA201200000G
45	M20x1.5	M20x1.5	Y3H345002T000007	Y3H345002T00000G	1/2"BSPP	20	20	Y3H3BA2022000007	Y3H3BA202200000G
45	M25x1.5	0	Y3H345001T500007	Y3H345001T50000G	1/2"BSPP	25	0	Y3H3BA2012500007	Y3H3BA201250000G
45	M25x1.5	M25x1.5	Y3H345002T500007	Y3H345002T50000G	1/2"BSPP	25	25	Y3H3BA2022500007	Y3H3BA202250000G
50	0	0	Y3H3500000000007	Y3H350000000000G	1/2"BSPP	M20x1.5	0	Y3H3BA201T000007	Y3H3BA201T00000G
50	20	0	Y3H3500012000007	Y3H350001200000G	1/2"BSPP	M20x1.5	M20x1.5	Y3H3BA202T000007	Y3H3BA202T00000G
50	20	20	Y3H3500022000007	Y3H350002200000G	1/2"BSPP	M25x1.5	0	Y3H3BA201T500007	Y3H3BA201T50000G
50	25	0	Y3H3500012500007	Y3H350001250000G	1/2"BSPP	M25x1.5	M25x1.5	Y3H3BA202T500007	Y3H3BA202T50000G
50	25	25	Y3H3500022500007	Y3H350002250000G					

Cable gland not included in these reference, consult us if you want them.  
Red dimensions inside rectangular frames are used for accessories assembly.



# Aluminum and plastic composite enclosure, with polycarbonate cover, for immersion heater with 30 mm offset fitting

Size(mm)	Volume(cm <sup>3</sup> )	Material	Protection grade		Model
182 x 132 x 130	2435	Aluminum + Polycarbonate	IP69K	IK10	<b>Y3G1</b> (P1)

## Suitable for

- Temperature sensor
- Immersion heater
- Finned heater
- Thermostat
- Level sensor
- Electronic board

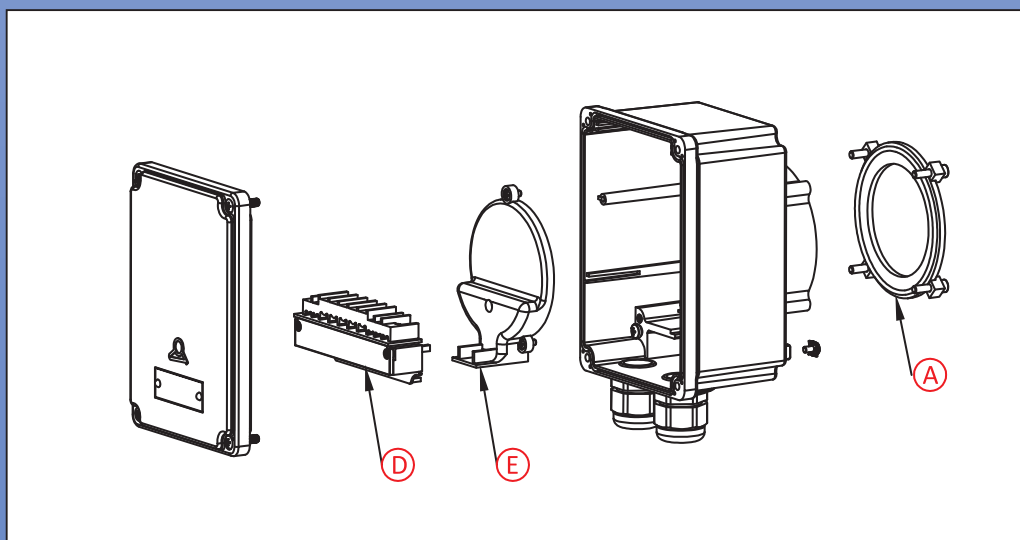
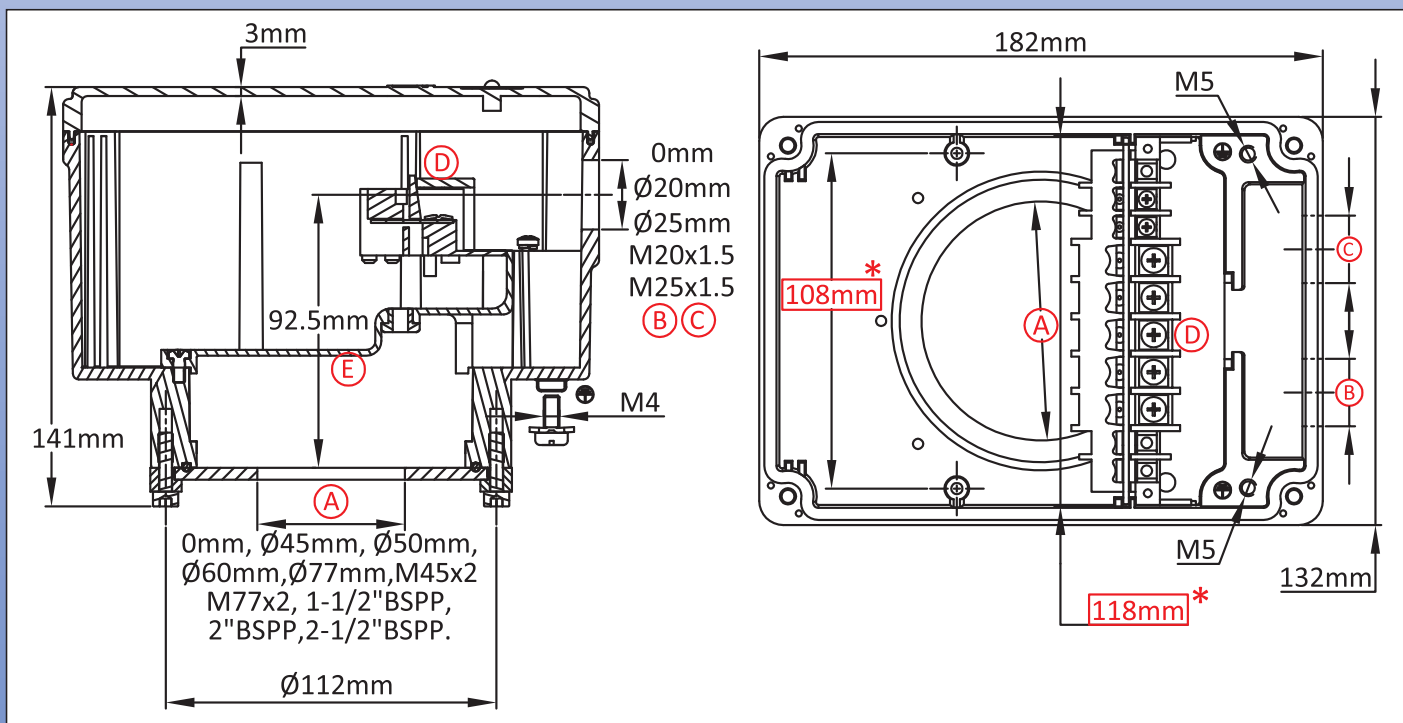

## Links



Page  
(.pdf)



Drawing 2D  
(.dwg)



Drawing 3D  
(.stp)

Cable gland not included in these reference, consult us if you want them.

Red dimensions inside rectangular frames are used for accessories assembly.

## Main references

Ⓐ(mm)	Ⓑ(mm)	Ⓒ(mm)	Not painted	Painted	Ⓐ(mm)	Ⓑ(mm)	Ⓒ(mm)	Not painted	Painted
0	0	0	Y3G1000000J1007	Y3G1000000J100G	M45x2	0	0	Y3G1M450000J1007	Y3G1M450000J100G
0	20	0	Y3G10000120J1007	Y3G10000120J100G	M45x2	20	0	Y3G1M450120J1007	Y3G1M450120J100G
0	20	20	Y3G10000220J1007	Y3G10000220J100G	M45x2	20	20	Y3G1M450220J1007	Y3G1M450220J100G
0	25	0	Y3G10000125J1007	Y3G10000125J100G	M45x2	25	0	Y3G1M450125J1007	Y3G1M450125J100G
0	25	25	Y3G10000225J1007	Y3G10000225J100G	M45x2	25	25	Y3G1M450225J1007	Y3G1M450225J100G
0	M20x1.5	0	Y3G100001T0J1007	Y3G100001T0J100G	M45x2	M20x1.5	0	Y3G1M4501T0J1007	Y3G1M4501T0J100G
0	M20x1.5	M20x1.5	Y3G100002T0J1007	Y3G100002T0J100G	M45x2	M20x1.5	M20x1.5	Y3G1M4502T0J1007	Y3G1M4502T0J100G
0	M25x1.5	0	Y3G100001T5J1007	Y3G100001T5J100G	M45x2	M25x1.5	0	Y3G1M4501T5J1007	Y3G1M4501T5J100G
0	M25x1.5	M25x1.5	Y3G100002T5J1007	Y3G100002T5J100G	M45x2	M25x1.5	M25x1.5	Y3G1M4502T5J1007	Y3G1M4502T5J100G
45	0	0	Y3G1450000J1007	Y3G1450000J100G	M77x2	0	0	Y3G1M770000J1007	Y3G1M770000J100G
45	20	0	Y3G14500120J1007	Y3G14500120J100G	M77x2	20	0	Y3G1M770120J1007	Y3G1M770120J100G
45	20	20	Y3G14500220J1007	Y3G14500220J100G	M77x2	20	20	Y3G1M770220J1007	Y3G1M770220J100G
45	25	0	Y3G14500125J1007	Y3G14500125J100G	M77x2	25	0	Y3G1M770125J1007	Y3G1M770125J100G
45	25	25	Y3G14500225J1007	Y3G14500225J100G	M77x2	25	25	Y3G1M770225J1007	Y3G1M770225J100G
45	M20x1.5	0	Y3G145001T0J1007	Y3G145001T0J100G	M77x2	M20x1.5	0	Y3G1M7701T0J1007	Y3G1M7701T0J100G
45	M20x1.5	M20x1.5	Y3G145002T0J1007	Y3G145002T0J100G	M77x2	M20x1.5	M20x1.5	Y3G1M7702T0J1007	Y3G1M7702T0J100G
45	M25x1.5	0	Y3G145001T5J1007	Y3G145001T5J100G	M77x2	M25x1.5	0	Y3G1M7701T5J1007	Y3G1M7701T5J100G
45	M25x1.5	M25x1.5	Y3G145002T5J1007	Y3G145002T5J100G	M77x2	M25x1.5	M25x1.5	Y3G1M7702T5J1007	Y3G1M7702T5J100G
50	0	0	Y3G1500000J1007	Y3G1500000J100G	1½"BSPP	0	0	Y3G1BA20000J1007	Y3G1BA20000J100G
50	20	0	Y3G15000120J1007	Y3G15000120J100G	1½"BSPP	20	0	Y3G1BA20120J1007	Y3G1BA20120J100G
50	20	20	Y3G15000220J1007	Y3G15000220J100G	1½"BSPP	20	20	Y3G1BA20220J1007	Y3G1BA20220J100G
50	25	0	Y3G15000125J1007	Y3G15000125J100G	1½"BSPP	25	0	Y3G1BA20125J1007	Y3G1BA20125J100G
50	25	25	Y3G15000225J1007	Y3G15000225J100G	1½"BSPP	25	25	Y3G1BA20225J1007	Y3G1BA20225J100G
50	M20x1.5	0	Y3G150001T0J1007	Y3G150001T0J100G	1½"BSPP	M20x1.5	0	Y3G1BA201T0J1007	Y3G1BA201T0J100G
50	M20x1.5	M20x1.5	Y3G150002T0J1007	Y3G150002T0J100G	1½"BSPP	M20x1.5	M20x1.5	Y3G1BA202T0J1007	Y3G1BA202T0J100G
50	M25x1.5	0	Y3G150001T5J1007	Y3G150001T5J100G	1½"BSPP	M25x1.5	0	Y3G1BA201T5J1007	Y3G1BA201T5J100G
50	M25x1.5	M25x1.5	Y3G150002T5J1007	Y3G150002T5J100G	1½"BSPP	M25x1.5	M25x1.5	Y3G1BA202T5J1007	Y3G1BA202T5J100G
60	0	0	Y3G1600000J1007	Y3G1600000J100G	2"BSPP	0	0	Y3G1BB20000J1007	Y3G1BB20000J100G
60	20	0	Y3G16000120J1007	Y3G16000120J100G	2"BSPP	20	0	Y3G1BB20120J1007	Y3G1BB20120J100G
60	20	20	Y3G16000220J1007	Y3G16000220J100G	2"BSPP	20	20	Y3G1BB20220J1007	Y3G1BB20220J100G
60	25	0	Y3G16000125J1007	Y3G16000125J100G	2"BSPP	25	0	Y3G1BB20125J1007	Y3G1BB20125J100G
60	25	25	Y3G16000225J1007	Y3G16000225J100G	2"BSPP	25	25	Y3G1BB20225J1007	Y3G1BB20225J100G
60	M20x1.5	0	Y3G160001T0J1007	Y3G160001T0J100G	2"BSPP	M20x1.5	0	Y3G1BB201T0J1007	Y3G1BB201T0J100G
60	M20x1.5	M20x1.5	Y3G160002T0J1007	Y3G160002T0J100G	2"BSPP	M20x1.5	M20x1.5	Y3G1BB202T0J1007	Y3G1BB202T0J100G
60	M25x1.5	0	Y3G160001T5J1007	Y3G160001T5J100G	2"BSPP	M25x1.5	0	Y3G1BB201T5J1007	Y3G1BB201T5J100G
60	M25x1.5	M25x1.5	Y3G160002T5J1007	Y3G160002T5J100G	2"BSPP	M25x1.5	M25x1.5	Y3G1BB202T5J1007	Y3G1BB202T5J100G
77	0	0	Y3G1770000J1007	Y3G1770000J100G	2½"BSPP	0	0	Y3G1BC20000J1007	Y3G1BC20000J100G
77	20	0	Y3G17700120J1007	Y3G17700120J100G	2½"BSPP	20	0	Y3G1BC20120J1007	Y3G1BC20120J100G
77	20	20	Y3G17700220J1007	Y3G17700220J100G	2½"BSPP	20	20	Y3G1BC20220J1007	Y3G1BC20220J100G
77	25	0	Y3G17700125J1007	Y3G17700125J100G	2½"BSPP	25	0	Y3G1BC20125J1007	Y3G1BC20125J100G
77	25	25	Y3G17700225J1007	Y3G17700225J100G	2½"BSPP	25	25	Y3G1BC20225J1007	Y3G1BC20225J100G
77	M20x1.5	0	Y3G177001T0J1007	Y3G177001T0J100G	2½"BSPP	M20x1.5	0	Y3G1BC201T0J1007	Y3G1BC201T0J100G
77	M20x1.5	M20x1.5	Y3G177002T0J1007	Y3G177002T0J100G	2½"BSPP	M20x1.5	M20x1.5	Y3G1BC202T0J1007	Y3G1BC202T0J100G
77	M25x1.5	0	Y3G177001T5J1007	Y3G177001T5J100G	2½"BSPP	M25x1.5	0	Y3G1BC201T5J1007	Y3G1BC201T5J100G
77	M25x1.5	M25x1.5	Y3G177002T5J1007	Y3G177002T5J100G	2½"BSPP	M25x1.5	M25x1.5	Y3G1BC202T5J1007	Y3G1BC202T5J100G

Because of permanent improvement of our products, drawings, descriptions, features used on these data sheets are for guidance only and can be modified without prior advice

# Aluminum and plastic composite enclosure, with transparent window cover, for immersion heater with 30 mm offset fitting

Size(mm)	Volume(cm <sup>3</sup> )	Material	Protection grade		Model
<b>182 x 132 x 144</b>	<b>2575</b>	<b>Aluminum + PA66 + Polycarbonate</b>	<b>IP69K</b>	<b>IK10</b>	<b>Y3G2 (P1)</b>

Suitable for
<input type="checkbox"/> Temperature sensor
<input checked="" type="checkbox"/> Immersion heater
<input type="checkbox"/> Finned heater
<input checked="" type="checkbox"/> Thermostat
<input type="checkbox"/> Level sensor
<input checked="" type="checkbox"/> Electronic board

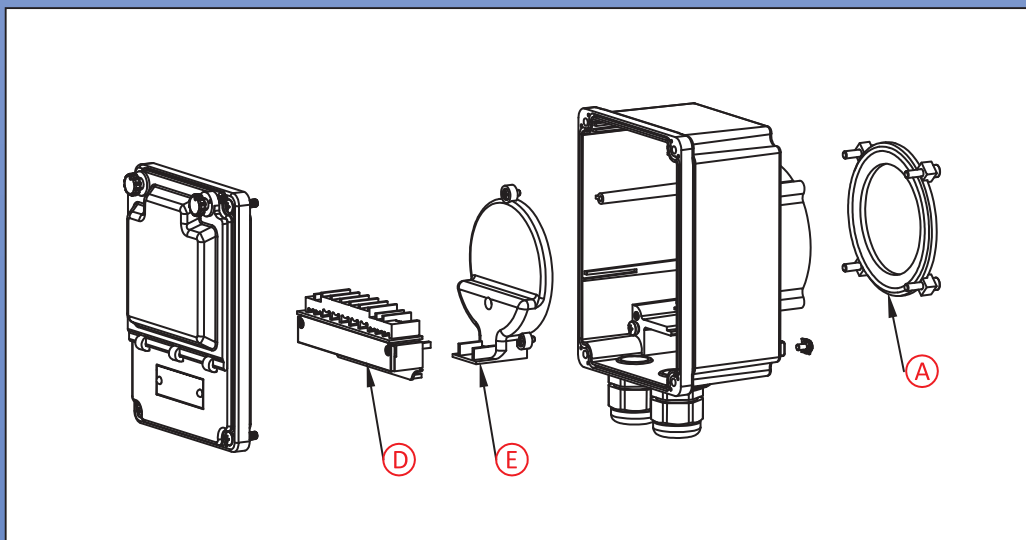
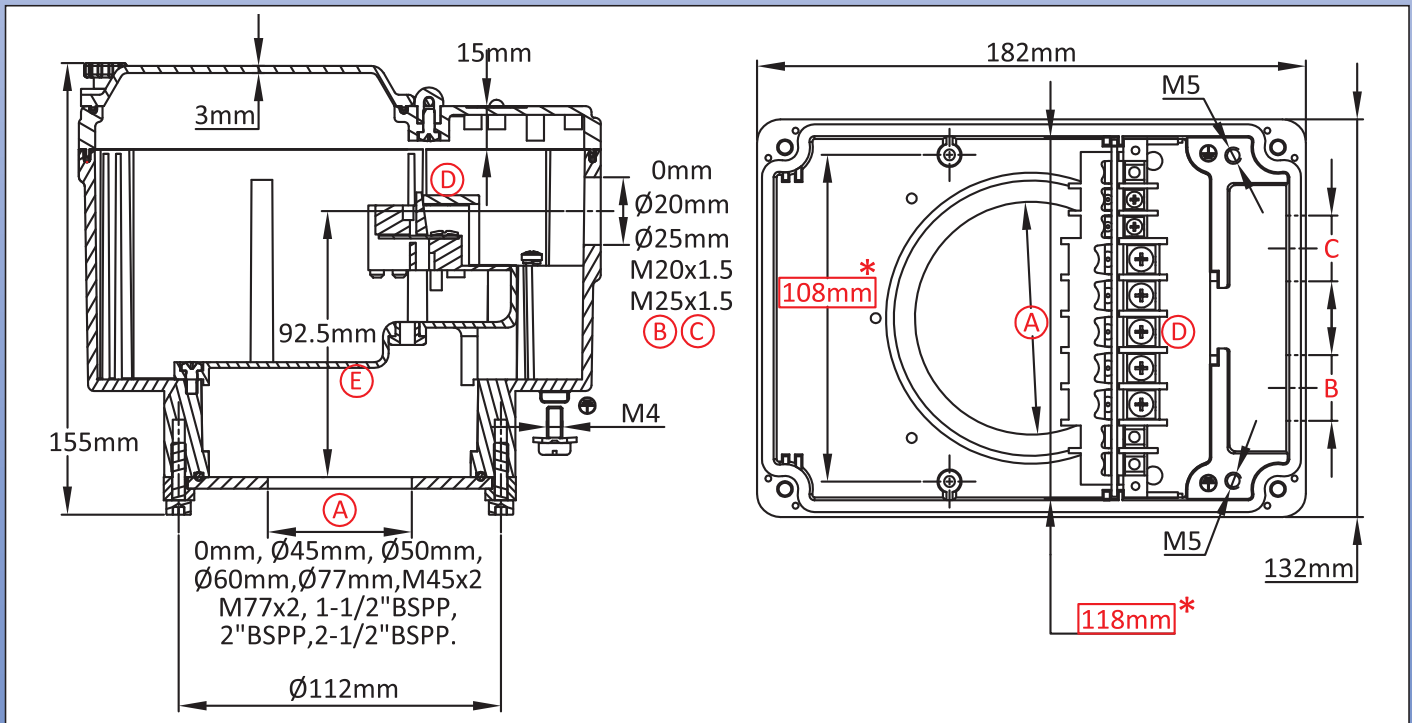

### Links

	Page (.pdf)
	Drawing 2D (.dwg)
	Drawing 3D (.stp)

Cable gland not included in these reference, consult us if you want them.  
Red dimensions inside rectangular frames are used for accessories assembly.

Because of permanent improvement of our products, drawings, descriptions, features used on these data sheets are for guidance only and can be modified without prior advice

## Main references

Ⓐ(mm)	Ⓑ(mm)	Ⓒ(mm)	Not painted	Painted	Ⓐ(mm)	Ⓑ(mm)	Ⓒ(mm)	Not painted	Painted
0	0	0	Y3G2000000J1007	Y3G2000000J100G	M45x2	0	0	Y3G2M450000J1007	Y3G2M450000J100G
0	20	0	Y3G20000120J1007	Y3G20000120J100G	M45x2	20	0	Y3G2M450120J1007	Y3G2M450120J100G
0	20	20	Y3G20000220J1007	Y3G20000220J100G	M45x2	20	20	Y3G2M450220J1007	Y3G2M450220J100G
0	25	0	Y3G20000125J1007	Y3G20000125J100G	M45x2	25	0	Y3G2M450125J1007	Y3G2M450125J100G
0	25	25	Y3G20000225J1007	Y3G20000225J100G	M45x2	25	25	Y3G2M450225J1007	Y3G2M450225J100G
0	M20x1.5	0	Y3G200001T0J1007	Y3G200001T0J100G	M45x2	M20x1.5	0	Y3G2M4501T0J1007	Y3G2M4501T0J100G
0	M20x1.5	M20x1.5	Y3G200002T0J1007	Y3G200002T0J100G	M45x2	M20x1.5	M20x1.5	Y3G2M4502T0J1007	Y3G2M4502T0J100G
0	M25x1.5	0	Y3G200001T5J1007	Y3G200001T5J100G	M45x2	M25x1.5	0	Y3G2M4501T5J1007	Y3G2M4501T5J100G
0	M25x1.5	M25x1.5	Y3G200002T5J1007	Y3G200002T5J100G	M45x2	M25x1.5	M25x1.5	Y3G2M4502T5J1007	Y3G2M4502T5J100G
45	0	0	Y3G2450000J1007	Y3G2450000J100G	M77x2	0	0	Y3G2M770000J1007	Y3G2M770000J100G
45	20	0	Y3G24500120J1007	Y3G24500120J100G	M77x2	20	0	Y3G2M770120J1007	Y3G2M770120J100G
45	20	20	Y3G24500220J1007	Y3G24500220J100G	M77x2	20	20	Y3G2M770220J1007	Y3G2M770220J100G
45	25	0	Y3G24500125J1007	Y3G24500125J100G	M77x2	25	0	Y3G2M770125J1007	Y3G2M770125J100G
45	25	25	Y3G24500225J1007	Y3G24500225J100G	M77x2	25	25	Y3G2M770225J1007	Y3G2M770225J100G
45	M20x1.5	0	Y3G245001T0J1007	Y3G245001T0J100G	M77x2	M20x1.5	0	Y3G2M7701T0J1007	Y3G2M7701T0J100G
45	M20x1.5	M20x1.5	Y3G245002T0J1007	Y3G245002T0J100G	M77x2	M20x1.5	M20x1.5	Y3G2M7702T0J1007	Y3G2M7702T0J100G
45	M25x1.5	0	Y3G245001T5J1007	Y3G245001T5J100G	M77x2	M25x1.5	0	Y3G2M7701T5J1007	Y3G2M7701T5J100G
45	M25x1.5	M25x1.5	Y3G245002T5J1007	Y3G245002T5J100G	M77x2	M25x1.5	M25x1.5	Y3G2M7702T5J1007	Y3G2M7702T5J100G
50	0	0	Y3G2500000J1007	Y3G2500000J100G	1½"BSPP	0	0	Y3G2BA20000J1007	Y3G2BA20000J100G
50	20	0	Y3G25000120J1007	Y3G25000120J100G	1½"BSPP	20	0	Y3G2BA20120J1007	Y3G2BA20120J100G
50	20	20	Y3G25000220J1007	Y3G25000220J100G	1½"BSPP	20	20	Y3G2BA20220J1007	Y3G2BA20220J100G
50	25	0	Y3G25000125J1007	Y3G25000125J100G	1½"BSPP	25	0	Y3G2BA20125J1007	Y3G2BA20125J100G
50	25	25	Y3G25000225J1007	Y3G25000225J100G	1½"BSPP	25	25	Y3G2BA20225J1007	Y3G2BA20225J100G
50	M20x1.5	0	Y3G250001T0J1007	Y3G250001T0J100G	1½"BSPP	M20x1.5	0	Y3G2BA201T0J1007	Y3G2BA201T0J100G
50	M20x1.5	M20x1.5	Y3G250002T0J1007	Y3G250002T0J100G	1½"BSPP	M20x1.5	M20x1.5	Y3G2BA202T0J1007	Y3G2BA202T0J100G
50	M25x1.5	0	Y3G250001T5J1007	Y3G250001T5J100G	1½"BSPP	M25x1.5	0	Y3G2BA201T5J1007	Y3G2BA201T5J100G
50	M25x1.5	M25x1.5	Y3G250002T5J1007	Y3G250002T5J100G	1½"BSPP	M25x1.5	M25x1.5	Y3G2BA202T5J1007	Y3G2BA202T5J100G
60	0	0	Y3G2600000J1007	Y3G2600000J100G	2"BSPP	0	0	Y3G2BB20000J1007	Y3G2BB20000J100G
60	20	0	Y3G26000120J1007	Y3G26000120J100G	2"BSPP	20	0	Y3G2BB20120J1007	Y3G2BB20120J100G
60	20	20	Y3G26000220J1007	Y3G26000220J100G	2"BSPP	20	20	Y3G2BB20220J1007	Y3G2BB20220J100G
60	25	0	Y3G26000125J1007	Y3G26000125J100G	2"BSPP	25	0	Y3G2BB20125J1007	Y3G2BB20125J100G
60	25	25	Y3G26000225J1007	Y3G26000225J100G	2"BSPP	25	25	Y3G2BB20225J1007	Y3G2BB20225J100G
60	M20x1.5	0	Y3G260001T0J1007	Y3G260001T0J100G	2"BSPP	M20x1.5	0	Y3G2BB201T0J1007	Y3G2BB201T0J100G
60	M20x1.5	M20x1.5	Y3G260002T0J1007	Y3G260002T0J100G	2"BSPP	M20x1.5	M20x1.5	Y3G2BB202T0J1007	Y3G2BB202T0J100G
60	M25x1.5	0	Y3G260001T5J1007	Y3G260001T5J100G	2"BSPP	M25x1.5	0	Y3G2BB201T5J1007	Y3G2BB201T5J100G
60	M25x1.5	M25x1.5	Y3G260002T5J1007	Y3G260002T5J100G	2"BSPP	M25x1.5	M25x1.5	Y3G2BB202T5J1007	Y3G2BB202T5J100G
77	0	0	Y3G2770000J1007	Y3G2770000J100G	2½"BSPP	0	0	Y3G2BC20000J1007	Y3G2BC20000J100G
77	20	0	Y3G27700120J1007	Y3G27700120J100G	2½"BSPP	20	0	Y3G2BC20120J1007	Y3G2BC20120J100G
77	20	20	Y3G27700220J1007	Y3G27700220J100G	2½"BSPP	20	20	Y3G2BC20220J1007	Y3G2BC20220J100G
77	25	0	Y3G27700125J1007	Y3G27700125J100G	2½"BSPP	25	0	Y3G2BC20125J1007	Y3G2BC20125J100G
77	25	25	Y3G27700225J1007	Y3G27700225J100G	2½"BSPP	25	25	Y3G2BC20225J1007	Y3G2BC20225J100G
77	M20x1.5	0	Y3G277001T0J1007	Y3G277001T0J100G	2½"BSPP	M20x1.5	0	Y3G2BC201T0J1007	Y3G2BC201T0J100G
77	M20x1.5	M20x1.5	Y3G277002T0J1007	Y3G277002T0J100G	2½"BSPP	M20x1.5	M20x1.5	Y3G2BC202T0J1007	Y3G2BC202T0J100G
77	M25x1.5	0	Y3G277001T5J1007	Y3G277001T5J100G	2½"BSPP	M25x1.5	0	Y3G2BC201T5J1007	Y3G2BC201T5J100G
77	M25x1.5	M25x1.5	Y3G277002T5J1007	Y3G277002T5J100G	2½"BSPP	M25x1.5	M25x1.5	Y3G2BC202T5J1007	Y3G2BC202T5J100G

Because of permanent improvement of our products, drawings, descriptions, features used on these data sheets are for guidance only and can be modified without prior advice

# All aluminum enclosure, for immersion heater with 30 mm offset fitting

Size(mm)	Volume(cm <sup>3</sup> )	Material	Protection grade		Model
182 x 132 x 144	2795	Aluminum	IP69K	IK10	<b>Y309</b> (P1)

### Suitable for

- Temperature sensor
- Immersion heater
- Finned heater
- Thermostat
- Level sensor
- Electronic board

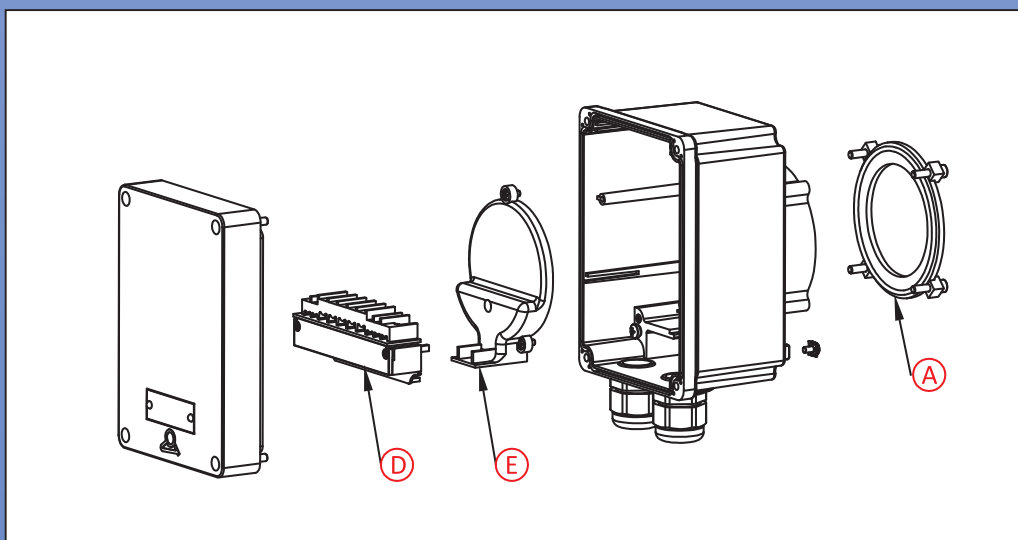
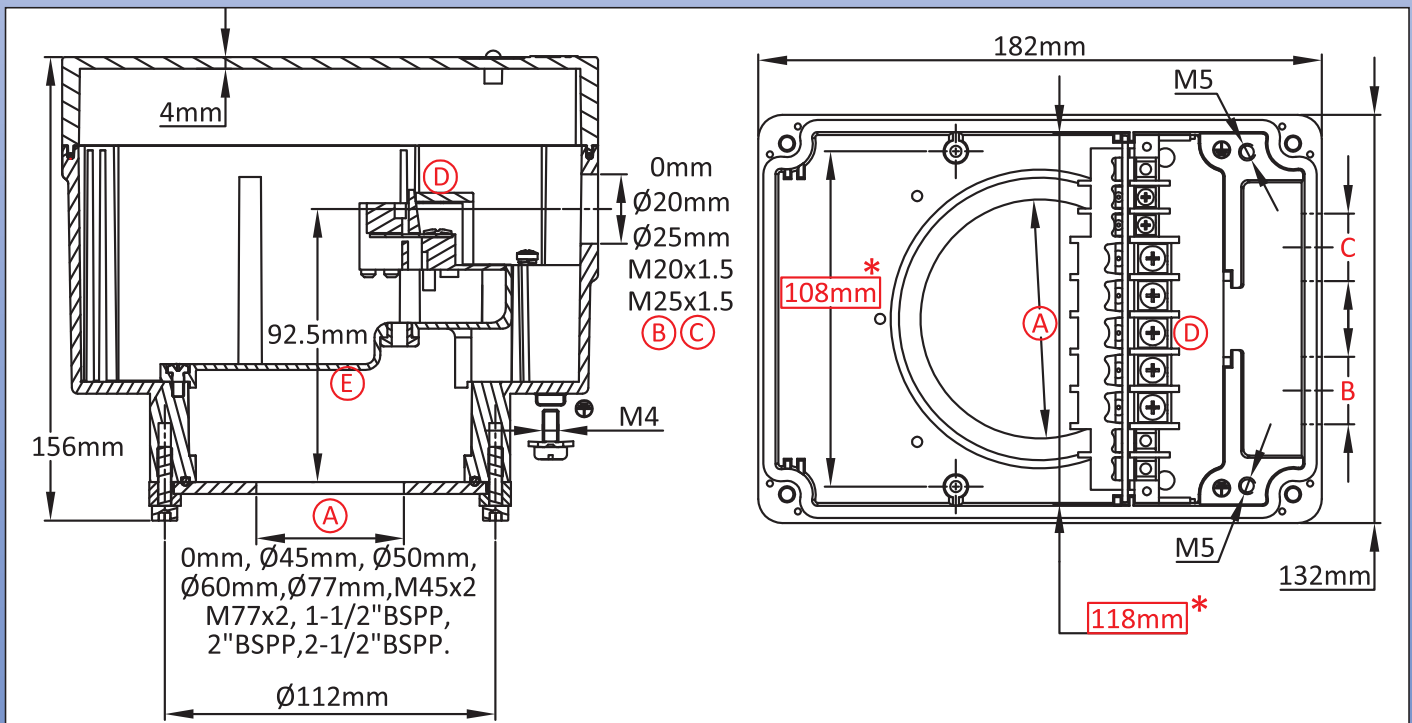

### Links



Page  
(.pdf)



Drawing 2D  
(.dwg)



Drawing 3D  
(.stp)

Cable gland not included in these reference, consult us if you want them.

Red dimensions inside rectangular frames are used for accessories assembly.

Because of permanent improvement of our products, drawings, descriptions, features used on these data sheets are for guidance only and can be modified without prior advice

## Main references

Ⓐ(mm)	Ⓑ(mm)	Ⓒ(mm)	Not painted	Painted	Ⓐ(mm)	Ⓑ(mm)	Ⓒ(mm)	Not painted	Painted
0	0	0	Y309000000J1007	Y309000000J100G	M45x2	0	0	Y309M450000J1007	Y309M450000J100G
0	20	0	Y3090000120J1007	Y3090000120J100G	M45x2	20	0	Y309M450120J1007	Y309M450120J100G
0	20	20	Y3090000220J1007	Y3090000220J100G	M45x2	20	20	Y309M450220J1007	Y309M450220J100G
0	25	0	Y3090000125J1007	Y3090000125J100G	M45x2	25	0	Y309M450125J1007	Y309M450125J100G
0	25	25	Y3090000225J1007	Y3090000225J100G	M45x2	25	25	Y309M450225J1007	Y309M450225J100G
0	M20x1.5	0	Y30900001T0J1007	Y30900001T0J100G	M45x2	M20x1.5	0	Y309M4501T0J1007	Y309M4501T0J100G
0	M20x1.5	M20x1.5	Y30900002T0J1007	Y30900002T0J100G	M45x2	M20x1.5	M20x1.5	Y309M4502T0J1007	Y309M4502T0J100G
0	M25x1.5	0	Y30900001T5J1007	Y30900001T5J100G	M45x2	M25x1.5	0	Y309M4501T5J1007	Y309M4501T5J100G
0	M25x1.5	M25x1.5	Y30900002T5J1007	Y30900002T5J100G	M45x2	M25x1.5	M25x1.5	Y309M4502T5J1007	Y309M4502T5J100G
45	0	0	Y309450000J1007	Y309450000J100G	M77x2	0	0	Y309M770000J1007	Y309M770000J100G
45	20	0	Y3094500120J1007	Y3094500120J100G	M77x2	20	0	Y309M770120J1007	Y309M770120J100G
45	20	20	Y3094500220J1007	Y3094500220J100G	M77x2	20	20	Y309M770220J1007	Y309M770220J100G
45	25	0	Y3094500125J1007	Y3094500125J100G	M77x2	25	0	Y309M770125J1007	Y309M770125J100G
45	25	25	Y3094500225J1007	Y3094500225J100G	M77x2	25	25	Y309M770225J1007	Y309M770225J100G
45	M20x1.5	0	Y30945001T0J1007	Y30945001T0J100G	M77x2	M20x1.5	0	Y309M7701T0J1007	Y309M7701T0J100G
45	M20x1.5	M20x1.5	Y30945002T0J1007	Y30945002T0J100G	M77x2	M20x1.5	M20x1.5	Y309M7702T0J1007	Y309M7702T0J100G
45	M25x1.5	0	Y30945001T5J1007	Y30945001T5J100G	M77x2	M25x1.5	0	Y309M7701T5J1007	Y309M7701T5J100G
45	M25x1.5	M25x1.5	Y30945002T5J1007	Y30945002T5J100G	M77x2	M25x1.5	M25x1.5	Y309M7702T5J1007	Y309M7702T5J100G
50	0	0	Y309500000J1007	Y309500000J100G	1½"BSPP	0	0	Y309BA20000J1007	Y309BA20000J100G
50	20	0	Y3095000120J1007	Y3095000120J100G	1½"BSPP	20	0	Y309BA20120J1007	Y309BA20120J100G
50	20	20	Y3095000220J1007	Y3095000220J100G	1½"BSPP	20	20	Y309BA20220J1007	Y309BA20220J100G
50	25	0	Y3095000125J1007	Y3095000125J100G	1½"BSPP	25	0	Y309BA20125J1007	Y309BA20125J100G
50	25	25	Y3095000225J1007	Y3095000225J100G	1½"BSPP	25	25	Y309BA20225J1007	Y309BA20225J100G
50	M20x1.5	0	Y30950001T0J1007	Y30950001T0J100G	1½"BSPP	M20x1.5	0	Y309BA201T0J1007	Y309BA201T0J100G
50	M20x1.5	M20x1.5	Y30950002T0J1007	Y30950002T0J100G	1½"BSPP	M20x1.5	M20x1.5	Y309BA202T0J1007	Y309BA202T0J100G
50	M25x1.5	0	Y30950001T5J1007	Y30950001T5J100G	1½"BSPP	M25x1.5	0	Y309BA201T5J1007	Y309BA201T5J100G
50	M25x1.5	M25x1.5	Y30950002T5J1007	Y30950002T5J100G	1½"BSPP	M25x1.5	M25x1.5	Y309BA202T5J1007	Y309BA202T5J100G
60	0	0	Y309600000J1007	Y309600000J100G	2"BSPP	0	0	Y309BB20000J1007	Y309BB20000J100G
60	20	0	Y3096000120J1007	Y3096000120J100G	2"BSPP	20	0	Y309BB20120J1007	Y309BB20120J100G
60	20	20	Y3096000220J1007	Y3096000220J100G	2"BSPP	20	20	Y309BB20220J1007	Y309BB20220J100G
60	25	0	Y3096000125J1007	Y3096000125J100G	2"BSPP	25	0	Y309BB20125J1007	Y309BB20125J100G
60	25	25	Y3096000225J1007	Y3096000225J100G	2"BSPP	25	25	Y309BB20225J1007	Y309BB20225J100G
60	M20x1.5	0	Y30960001T0J1007	Y30960001T0J100G	2"BSPP	M20x1.5	0	Y309BB201T0J1007	Y309BB201T0J100G
60	M20x1.5	M20x1.5	Y30960002T0J1007	Y30960002T0J100G	2"BSPP	M20x1.5	M20x1.5	Y309BB202T0J1007	Y309BB202T0J100G
60	M25x1.5	0	Y30960001T5J1007	Y30960001T5J100G	2"BSPP	M25x1.5	0	Y309BB201T5J1007	Y309BB201T5J100G
60	M25x1.5	M25x1.5	Y30960002T5J1007	Y30960002T5J100G	2"BSPP	M25x1.5	M25x1.5	Y309BB202T5J1007	Y309BB202T5J100G
77	0	0	Y309770000J1007	Y309770000J100G	2½"BSPP	0	0	Y309BC20000J1007	Y309BC20000J100G
77	20	0	Y3097700120J1007	Y3097700120J100G	2½"BSPP	20	0	Y309BC20120J1007	Y309BC20120J100G
77	20	20	Y3097700220J1007	Y3097700220J100G	2½"BSPP	20	20	Y309BC20220J1007	Y309BC20220J100G
77	25	0	Y3097700125J1007	Y3097700125J100G	2½"BSPP	25	0	Y309BC20125J1007	Y309BC20125J100G
77	25	25	Y3097700225J1007	Y3097700225J100G	2½"BSPP	25	25	Y309BC20225J1007	Y309BC20225J100G
77	M20x1.5	0	Y30977001T0J1007	Y30977001T0J100G	2½"BSPP	M20x1.5	0	Y309BC201T0J1007	Y309BC201T0J100G
77	M20x1.5	M20x1.5	Y30977002T0J1007	Y30977002T0J100G	2½"BSPP	M20x1.5	M20x1.5	Y309BC202T0J1007	Y309BC202T0J100G
77	M25x1.5	0	Y30977001T5J1007	Y30977001T5J100G	2½"BSPP	M25x1.5	0	Y309BC201T5J1007	Y309BC201T5J100G
77	M25x1.5	M25x1.5	Y30977002T5J1007	Y30977002T5J100G	2½"BSPP	M25x1.5	M25x1.5	Y309BC202T5J1007	Y309BC202T5J100G

Because of permanent improvement of our products, drawings, descriptions, features used on these data sheets are for guidance only and can be modified without prior advice

# Composite aluminum and plastic enclosure, with polycarbonate plain cover, for immersion heater with high 120mm offset fitting

Size(mm)	Volume(cm <sup>3</sup> )	Material	Protection grade		Model
182 x 132 x 210	3066	Aluminum + Polycarbonate	IP69K	IK10	<b>Y3J1</b> (P1)

### Suitable for

- Temperature sensor
- Immersion heater
- Finned heater
- Thermostat
- Level sensor
- Electronic board

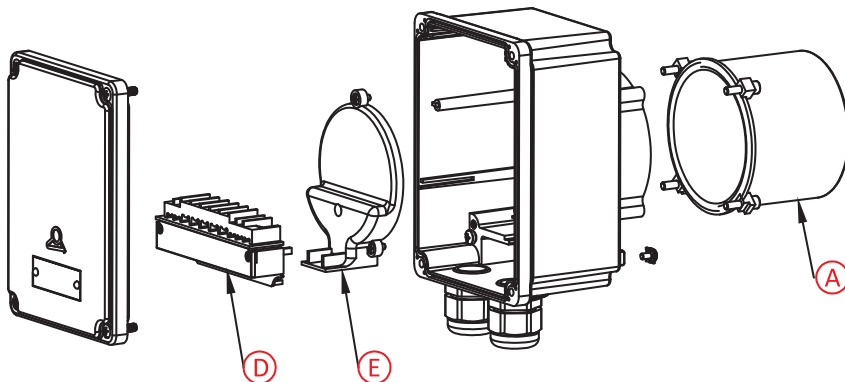
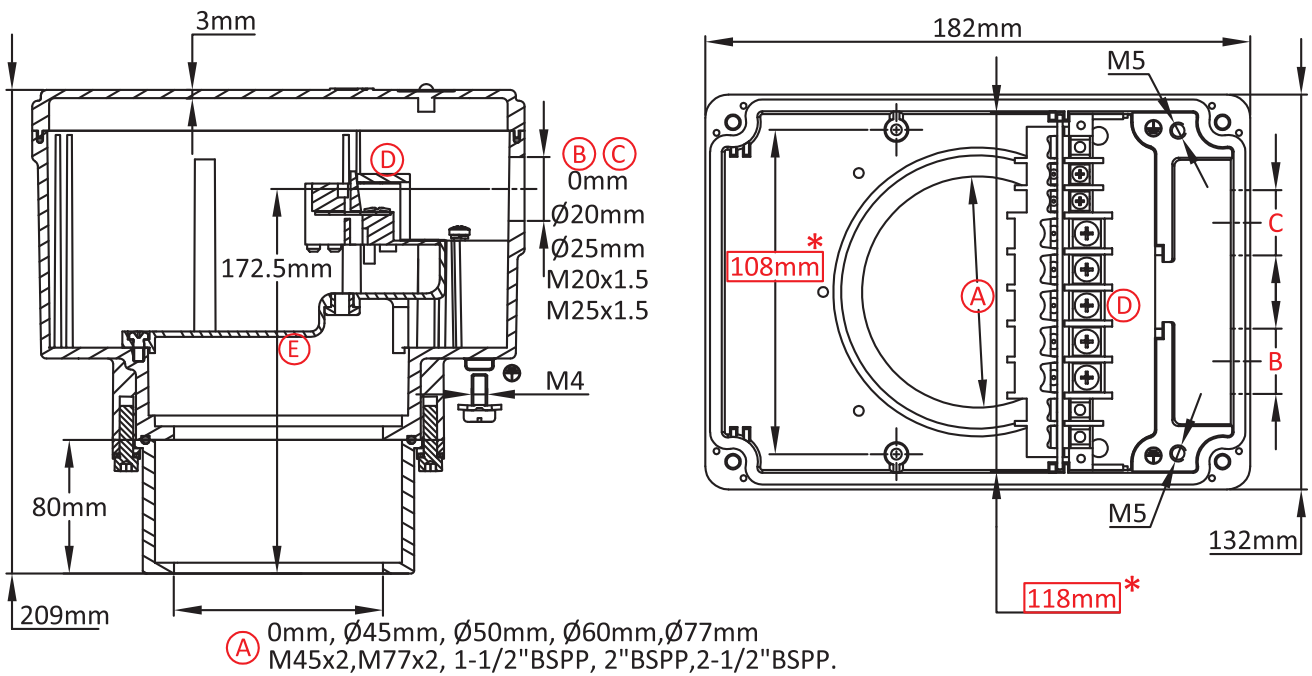

### Links



Page  
(.pdf)



Drawing 2D  
(.dwg)



Drawing 3D  
(.stp)

Cable gland not included in these reference, consult us if you want them.

Red dimensions inside rectangular frames are used for accessories assembly.

**Main references**

A(mm)	B(mm)	C(mm)	Not painted	Painted	A(mm)	B(mm)	C(mm)	Not painted	Painted
0	0	0	Y3J10000000J1007	Y3J10000000J100G	M45x2	0	0	Y3J1M450000J1007	Y3J1M450000J100G
0	20	0	Y3J10000120J1007	Y3J10000120J100G	M45x2	20	0	Y3J1M450120J1007	Y3J1M450120J100G
0	20	20	Y3J10000220J1007	Y3J10000220J100G	M45x2	20	20	Y3J1M450220J1007	Y3J1M450220J100G
0	25	0	Y3J10000125J1007	Y3J10000125J100G	M45x2	25	0	Y3J1M450125J1007	Y3J1M450125J100G
0	25	25	Y3J10000225J1007	Y3J10000225J100G	M45x2	25	25	Y3J1M450225J1007	Y3J1M450225J100G
0	M20x1.5	0	Y3J100001T0J1007	Y3J100001T0J100G	M45x2	M20x1.5	0	Y3J1M4501T0J1007	Y3J1M4501T0J100G
0	M20x1.5	M20x1.5	Y3J100002T0J1007	Y3J100002T0J100G	M45x2	M20x1.5	M20x1.5	Y3J1M4502T0J1007	Y3J1M4502T0J100G
0	M25x1.5	0	Y3J100001T5J1007	Y3J100001T5J100G	M45x2	M25x1.5	0	Y3J1M4501T5J1007	Y3J1M4501T5J100G
0	M25x1.5	M25x1.5	Y3J100002T5J1007	Y3J100002T5J100G	M45x2	M25x1.5	M25x1.5	Y3J1M4502T5J1007	Y3J1M4502T5J100G
45	0	0	Y3J14500000J1007	Y3J14500000J100G	M77x2	0	0	Y3J1M770000J1007	Y3J1M770000J100G
45	20	0	Y3J14500120J1007	Y3J14500120J100G	M77x2	20	0	Y3J1M770120J1007	Y3J1M770120J100G
45	20	20	Y3J14500220J1007	Y3J14500220J100G	M77x2	20	20	Y3J1M770220J1007	Y3J1M770220J100G
45	25	0	Y3J14500125J1007	Y3J14500125J100G	M77x2	25	0	Y3J1M770125J1007	Y3J1M770125J100G
45	25	25	Y3J14500225J1007	Y3J14500225J100G	M77x2	25	25	Y3J1M770225J1007	Y3J1M770225J100G
45	M20x1.5	0	Y3J145001T0J1007	Y3J145001T0J100G	M77x2	M20x1.5	0	Y3J1M7701T0J1007	Y3J1M7701T0J100G
45	M20x1.5	M20x1.5	Y3J145002T0J1007	Y3J145002T0J100G	M77x2	M20x1.5	M20x1.5	Y3J1M7702T0J1007	Y3J1M7702T0J100G
45	M25x1.5	0	Y3J145001T5J1007	Y3J145001T5J100G	M77x2	M25x1.5	0	Y3J1M7701T5J1007	Y3J1M7701T5J100G
45	M25x1.5	M25x1.5	Y3J145002T5J1007	Y3J145002T5J100G	M77x2	M25x1.5	M25x1.5	Y3J1M7702T5J1007	Y3J1M7702T5J100G
50	0	0	Y3J15000000J1007	Y3J15000000J100G	1½"BSPP	0	0	Y3J1BA20000J1007	Y3J1BA20000J100G
50	20	0	Y3J15000120J1007	Y3J15000120J100G	1½"BSPP	20	0	Y3J1BA20120J1007	Y3J1BA20120J100G
50	20	20	Y3J15000220J1007	Y3J15000220J100G	1½"BSPP	20	20	Y3J1BA20220J1007	Y3J1BA20220J100G
50	25	0	Y3J15000125J1007	Y3J15000125J100G	1½"BSPP	25	0	Y3J1BA20125J1007	Y3J1BA20125J100G
50	25	25	Y3J15000225J1007	Y3J15000225J100G	1½"BSPP	25	25	Y3J1BA20225J1007	Y3J1BA20225J100G
50	M20x1.5	0	Y3J150001T0J1007	Y3J150001T0J100G	1½"BSPP	M20x1.5	0	Y3J1BA201T0J1007	Y3J1BA201T0J100G
50	M20x1.5	M20x1.5	Y3J150002T0J1007	Y3J150002T0J100G	1½"BSPP	M20x1.5	M20x1.5	Y3J1BA202T0J1007	Y3J1BA202T0J100G
50	M25x1.5	0	Y3J150001T5J1007	Y3J150001T5J100G	1½"BSPP	M25x1.5	0	Y3J1BA201T5J1007	Y3J1BA201T5J100G
50	M25x1.5	M25x1.5	Y3J150002T5J1007	Y3J150002T5J100G	1½"BSPP	M25x1.5	M25x1.5	Y3J1BA202T5J1007	Y3J1BA202T5J100G
60	0	0	Y3J16000000J1007	Y3J16000000J100G	2"BSPP	0	0	Y3J1BB20000J1007	Y3J1BB20000J100G
60	20	0	Y3J16000120J1007	Y3J16000120J100G	2"BSPP	20	0	Y3J1BB20120J1007	Y3J1BB20120J100G
60	20	20	Y3J16000220J1007	Y3J16000220J100G	2"BSPP	20	20	Y3J1BB20220J1007	Y3J1BB20220J100G
60	25	0	Y3J16000125J1007	Y3J16000125J100G	2"BSPP	25	0	Y3J1BB20125J1007	Y3J1BB20125J100G
60	25	25	Y3J16000225J1007	Y3J16000225J100G	2"BSPP	25	25	Y3J1BB20225J1007	Y3J1BB20225J100G
60	M20x1.5	0	Y3J160001T0J1007	Y3J160001T0J100G	2"BSPP	M20x1.5	0	Y3J1BB201T0J1007	Y3J1BB201T0J100G
60	M20x1.5	M20x1.5	Y3J160002T0J1007	Y3J160002T0J100G	2"BSPP	M20x1.5	M20x1.5	Y3J1BB202T0J1007	Y3J1BB202T0J100G
60	M25x1.5	0	Y3J160001T5J1007	Y3J160001T5J100G	2"BSPP	M25x1.5	0	Y3J1BB201T5J1007	Y3J1BB201T5J100G
60	M25x1.5	M25x1.5	Y3J160002T5J1007	Y3J160002T5J100G	2"BSPP	M25x1.5	M25x1.5	Y3J1BB202T5J1007	Y3J1BB202T5J100G
77	0	0	Y3J17700000J1007	Y3J17700000J100G	2½"BSPP	0	0	Y3J1BC20000J1007	Y3J1BC20000J100G
77	20	0	Y3J17700120J1007	Y3J17700120J100G	2½"BSPP	20	0	Y3J1BC20120J1007	Y3J1BC20120J100G
77	20	20	Y3J17700220J1007	Y3J17700220J100G	2½"BSPP	20	20	Y3J1BC20220J1007	Y3J1BC20220J100G
77	25	0	Y3J17700125J1007	Y3J17700125J100G	2½"BSPP	25	0	Y3J1BC20125J1007	Y3J1BC20125J100G
77	25	25	Y3J17700225J1007	Y3J17700225J100G	2½"BSPP	25	25	Y3J1BC20225J1007	Y3J1BC20225J100G
77	M20x1.5	0	Y3J177001T0J1007	Y3J177001T0J100G	2½"BSPP	M20x1.5	0	Y3J1BC201T0J1007	Y3J1BC201T0J100G
77	M20x1.5	M20x1.5	Y3J177002T0J1007	Y3J177002T0J100G	2½"BSPP	M20x1.5	M20x1.5	Y3J1BC202T0J1007	Y3J1BC202T0J100G
77	M25x1.5	0	Y3J177001T5J1007	Y3J177001T5J100G	2½"BSPP	M25x1.5	0	Y3J1BC201T5J1007	Y3J1BC201T5J100G
77	M25x1.5	M25x1.5	Y3J177002T5 J1007	Y3J177002T5J100G	2½"BSPP	M25x1.5	M25x1.5	Y3J1BC202T5J1007	Y3J1BC202T5J100G

Because of permanent improvement of our products, drawings, descriptions, features used on these data sheets are for guidance only and can be modified without prior advice





# Composite aluminum and plastic enclosure, with polycarbonate transparent window, for immersion heater with high 120mm offset fitting

Size(mm)	Volume(cm <sup>3</sup> )	Material	Protection grade		Model
182 x 132 x 225	3206	Aluminum + PA66 + Polycarbonate	IP69K	IK10	<b>Y3J2</b> (P1)

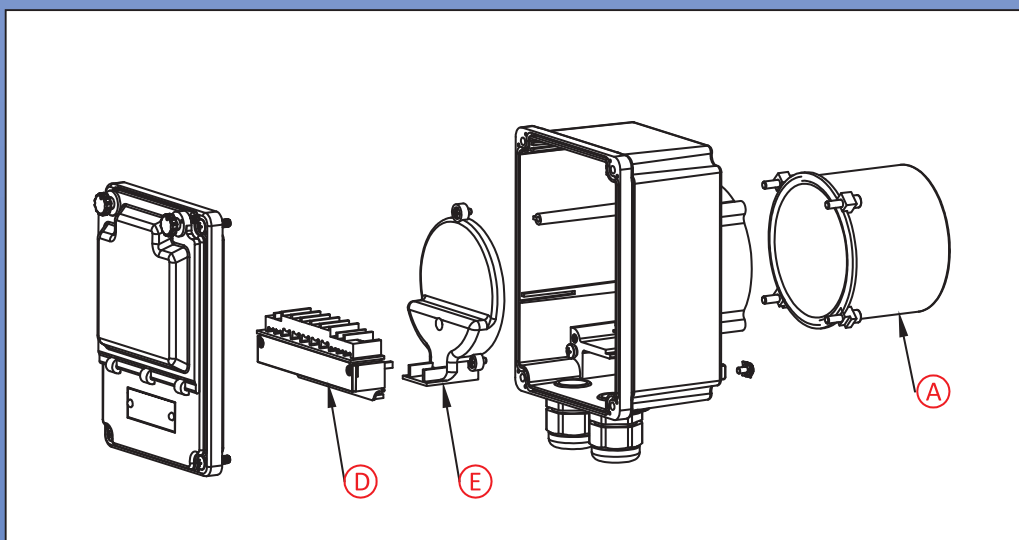
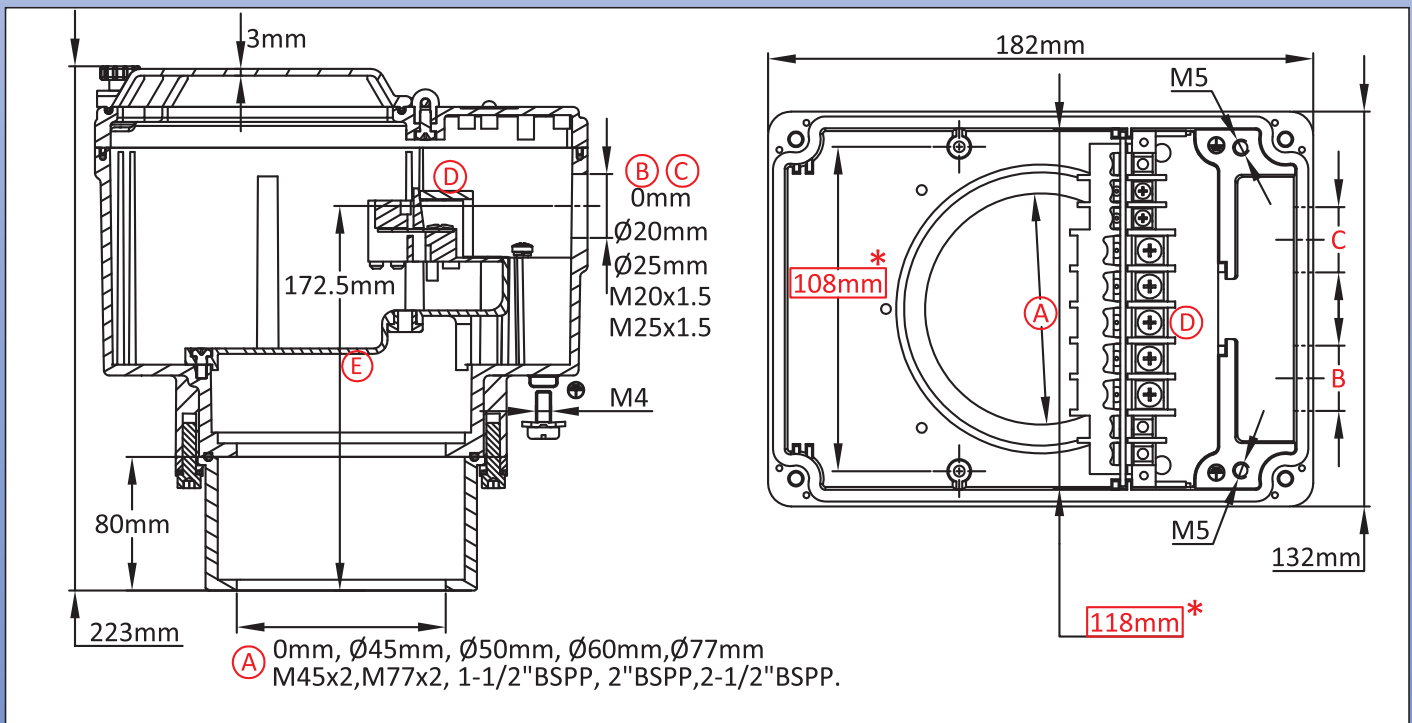
- Suitable for**
- Temperature sensor
  - Immersion heater
  - Finned heater
  - Thermostat
  - Level sensor
  - Electronic board



**Links**

-  Page (.pdf)
-  Drawing 2D (.dwg)
-  Drawing 3D (.stp)

Cable gland not included in these reference, consult us if you want them.  
 Red dimensions inside rectangular frames are used for accessories assembly.

Because of permanent improvement of our products, drawings, descriptions, features used on these data sheets are for guidance only and can be modified without prior advice

Main references

A(mm)	B(mm)	C(mm)	Not painted	Painted	A(mm)	B(mm)	C(mm)	Not painted	Painted
0	0	0	Y3J2000000J1007	Y3J2000000J100G	M45×2	0	0	Y3J2M450000J1007	Y3J2M450000J100G
0	20	0	Y3J20000120J1007	Y3J20000120J100G	M45×2	20	0	Y3J2M450120J1007	Y3J2M450120J100G
0	20	20	Y3J20000220J1007	Y3J20000220J100G	M45×2	20	20	Y3J2M450220J1007	Y3J2M450220J100G
0	25	0	Y3J20000125J1007	Y3J20000125J100G	M45×2	25	0	Y3J2M450125J1007	Y3J2M450125J100G
0	25	25	Y3J20000225J1007	Y3J20000225J100G	M45×2	25	25	Y3J2M450225J1007	Y3J2M450225J100G
0	M20×1.5	0	Y3J200001T0J1007	Y3J200001T0J100G	M45×2	M20×1.5	0	Y3J2M4501T0J1007	Y3J2M4501T0J100G
0	M20×1.5	M20×1.5	Y3J200002T0J1007	Y3J200002T0J100G	M45×2	M20×1.5	M20×1.5	Y3J2M4502T0J1007	Y3J2M4502T0J100G
0	M25×1.5	0	Y3J200001T5J1007	Y3J200001T5J100G	M45×2	M25×1.5	0	Y3J2M4501T5J1007	Y3J2M4501T5J100G
0	M25×1.5	M25×1.5	Y3J200002T5J1007	Y3J200002T5J100G	M45×2	M25×1.5	M25×1.5	Y3J2M4502T5J1007	Y3J2M4502T5J100G
45	0	0	Y3J2450000J1007	Y3J2450000J100G	M77×2	0	0	Y3J2M770000J1007	Y3J2M770000J100G
45	20	0	Y3J24500120J1007	Y3J24500120J100G	M77×2	20	0	Y3J2M770120J1007	Y3J2M770120J100G
45	20	20	Y3J24500220J1007	Y3J24500220J100G	M77×2	20	20	Y3J2M770220J1007	Y3J2M770220J100G
45	25	0	Y3J24500125J1007	Y3J24500125J100G	M77×2	25	0	Y3J2M770125J1007	Y3J2M770125J100G
45	25	25	Y3J24500225J1007	Y3J24500225J100G	M77×2	25	25	Y3J2M770225J1007	Y3J2M770225J100G
45	M20×1.5	0	Y3J245001T0J1007	Y3J245001T0J100G	M77×2	M20×1.5	0	Y3J2M7701T0J1007	Y3J2M7701T0J100G
45	M20×1.5	M20×1.5	Y3J245002T0J1007	Y3J245002T0J100G	M77×2	M20×1.5	M20×1.5	Y3J2M7702T0J1007	Y3J2M7702T0J100G
45	M25×1.5	0	Y3J245001T5J1007	Y3J245001T5J100G	M77×2	M25×1.5	0	Y3J2M7701T5J1007	Y3J2M7701T5J100G
45	M25×1.5	M25×1.5	Y3J245002T5J1007	Y3J245002T5J100G	M77×2	M25×1.5	M25×1.5	Y3J2M7702T5J1007	Y3J2M7702T5J100G
50	0	0	Y3J2500000J1007	Y3J2500000J100G	1½"BSPP	0	0	Y3J2BA20000J1007	Y3J2BA20000J100G
50	20	0	Y3J25000120J1007	Y3J25000120J100G	1½"BSPP	20	0	Y3J2BA20120J1007	Y3J2BA20120J100G
50	20	20	Y3J25000220J1007	Y3J25000220J100G	1½"BSPP	20	20	Y3J2BA20220J1007	Y3J2BA20220J100G
50	25	0	Y3J25000125J1007	Y3J25000125J100G	1½"BSPP	25	0	Y3J2BA20125J1007	Y3J2BA20125J100G
50	25	25	Y3J25000225J1007	Y3J25000225J100G	1½"BSPP	25	25	Y3J2BA20225J1007	Y3J2BA20225J100G
50	M20×1.5	0	Y3J250001T0J1007	Y3J250001T0J100G	1½"BSPP	M20×1.5	0	Y3J2BA201T0J1007	Y3J2BA201T0J100G
50	M20×1.5	M20×1.5	Y3J250002T0J1007	Y3J250002T0J100G	1½"BSPP	M20×1.5	M20×1.5	Y3J2BA202T0J1007	Y3J2BA202T0J100G
50	M25×1.5	0	Y3J250001T5J1007	Y3J250001T5J100G	1½"BSPP	M25×1.5	0	Y3J2BA201T5J1007	Y3J2BA201T5J100G
50	M25×1.5	M25×1.5	Y3J250002T5J1007	Y3J250002T5J100G	1½"BSPP	M25×1.5	M25×1.5	Y3J2BA202T5J1007	Y3J2BA202T5J100G
60	0	0	Y3J2600000J1007	Y3J2600000J100G	2"BSPP	0	0	Y3J2BB20000J1007	Y3J2BB20000J100G
60	20	0	Y3J26000120J1007	Y3J26000120J100G	2"BSPP	20	0	Y3J2BB20120J1007	Y3J2BB20120J100G
60	20	20	Y3J26000220J1007	Y3J26000220J100G	2"BSPP	20	20	Y3J2BB20220J1007	Y3J2BB20220J100G
60	25	0	Y3J26000125J1007	Y3J26000125J100G	2"BSPP	25	0	Y3J2BB20125J1007	Y3J2BB20125J100G
60	25	25	Y3J26000225J1007	Y3J26000225J100G	2"BSPP	25	25	Y3J2BB20225J1007	Y3J2BB20225J100G
60	M20×1.5	0	Y3J260001T0J1007	Y3J260001T0J100G	2"BSPP	M20×1.5	0	Y3J2BB201T0J1007	Y3J2BB201T0J100G
60	M20×1.5	M20×1.5	Y3J260002T0J1007	Y3J260002T0J100G	2"BSPP	M20×1.5	M20×1.5	Y3J2BB202T0J1007	Y3J2BB202T0J100G
60	M25×1.5	0	Y3J260001T5J1007	Y3J260001T5J100G	2"BSPP	M25×1.5	0	Y3J2BB201T5J1007	Y3J2BB201T5J100G
60	M25×1.5	M25×1.5	Y3J260002T5J1007	Y3J260002T5J100G	2"BSPP	M25×1.5	M25×1.5	Y3J2BB202T5J1007	Y3J2BB202T5J100G
77	0	0	Y3J2770000J1007	Y3J2770000J100G	2½"BSPP	0	0	Y3J2BC20000J1007	Y3J2BC20000J100G
77	20	0	Y3J27700120J1007	Y3J27700120J100G	2½"BSPP	20	0	Y3J2BC20120J1007	Y3J2BC20120J100G
77	20	20	Y3J27700220J1007	Y3J27700220J100G	2½"BSPP	20	20	Y3J2BC20220J1007	Y3J2BC20220J100G
77	25	0	Y3J27700125J1007	Y3J27700125J100G	2½"BSPP	25	0	Y3J2BC20125J1007	Y3J2BC20125J100G
77	25	25	Y3J27700225J1007	Y3J27700225J100G	2½"BSPP	25	25	Y3J2BC20225J1007	Y3J2BC20225J100G
77	M20×1.5	0	Y3J277001T0J1007	Y3J277001T0J100G	2½"BSPP	M20×1.5	0	Y3J2BC201T0J1007	Y3J2BC201T0J100G
77	M20×1.5	M20×1.5	Y3J277002T0J1007	Y3J277002T0J100G	2½"BSPP	M20×1.5	M20×1.5	Y3J2BC202T0J1007	Y3J2BC202T0J100G
77	M25×1.5	0	Y3J277001T5J1007	Y3J277001T5J100G	2½"BSPP	M25×1.5	0	Y3J2BC201T5J1007	Y3J2BC201T5J100G
77	M25×1.5	M25×1.5	Y3J277002T5J1007	Y3J277002T5J100G	2½"BSPP	M25×1.5	M25×1.5	Y3J2BC202T5J1007	Y3J2BC202T5J100G

Because of permanent improvement of our products, drawings, descriptions, features used on these data sheets are for guidance only and can be modified without prior advice

# All aluminum enclosure, with polycarbonate plain cover, for immersion heater with high 120mm offset fitting

Size(mm)	Volume(cm <sup>3</sup> )	Material	Protection grade		Model
182 x 132 x 225	3426	Aluminum	IP69K	IK10	<b>Y310</b> (P1)

### Suitable for

- Temperature sensor
- Immersion heater
- Finned heater
- Thermostat
- Level sensor
- Electronic board

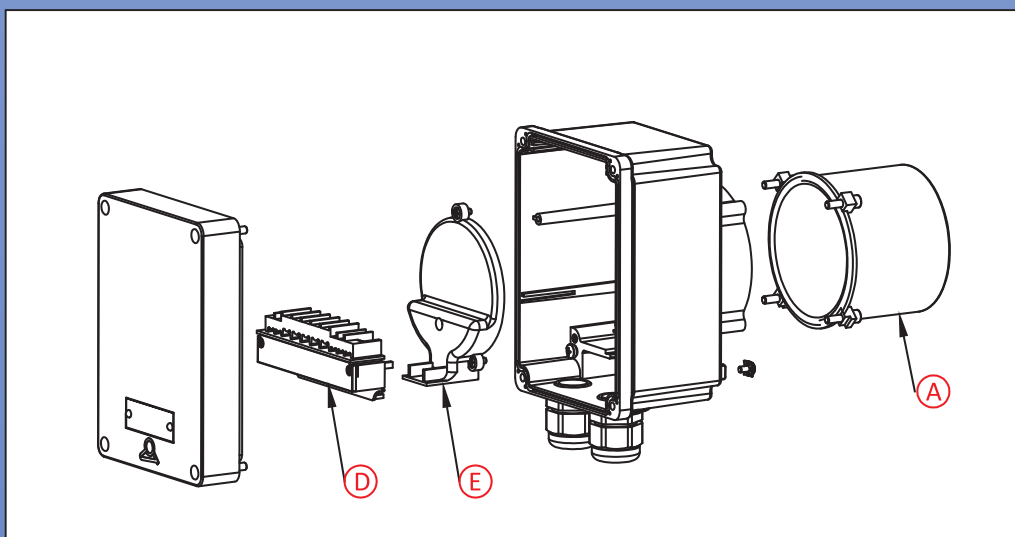
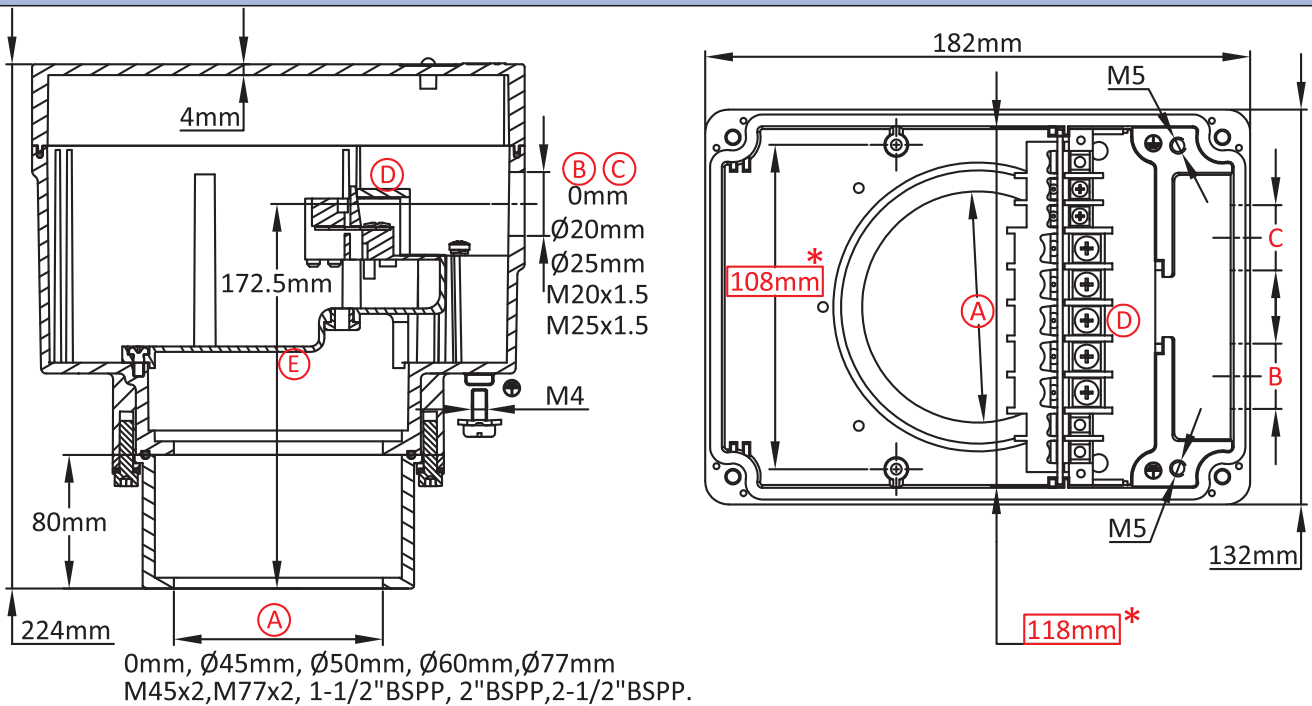

### Links



Page  
(.pdf)



Drawing 2D  
(.dwg)



Drawing 3D  
(.stp)

Cable gland not included in these reference, consult us if you want them.

Red dimensions inside rectangular frames are used for accessories assembly.

# All aluminum enclosure, with polycarbonate plain cover, for immersion heater with high 120mm offset fitting

**Y310**  
**(P2)**

## Main references

Ⓐ(mm)	Ⓑ(mm)	Ⓒ(mm)	Not painted	Painted	Ⓐ(mm)	Ⓑ(mm)	Ⓒ(mm)	Not painted	Painted
0	0	0	Y310000000J1007	Y310000000J100G	M45x2	0	0	Y310M450000J1007	Y310M450000J100G
0	20	0	Y3100000120J1007	Y3100000120J100G	M45x2	20	0	Y310M450120J1007	Y310M450120J100G
0	20	20	Y3100000220J1007	Y3100000220J100G	M45x2	20	20	Y310M450220J1007	Y310M450220J100G
0	25	0	Y3100000125J1007	Y3100000125J100G	M45x2	25	0	Y310M450125J1007	Y310M450125J100G
0	25	25	Y3100000225J1007	Y3100000225J100G	M45x2	25	25	Y310M450225J1007	Y310M450225J100G
0	M20x1.5	0	Y31000001T0J1007	Y31000001T0J100G	M45x2	M20x1.5	0	Y310M4501T0J1007	Y310M4501T0J100G
0	M20x1.5	M20x1.5	Y31000002T0J1007	Y31000002T0J100G	M45x2	M20x1.5	M20x1.5	Y310M4502T0J1007	Y310M4502T0J100G
0	M25x1.5	0	Y31000001T5J1007	Y31000001T5J100G	M45x2	M25x1.5	0	Y310M4501T5J1007	Y310M4501T5J100G
0	M25x1.5	M25x1.5	Y31000002T5J1007	Y31000002T5J100G	M45x2	M25x1.5	M25x1.5	Y310M4502T5J1007	Y310M4502T5J100G
45	0	0	Y310450000J1007	Y310450000J100G	M77x2	0	0	Y310M770000J1007	Y310M770000J100G
45	20	0	Y3104500120J1007	Y3104500120J100G	M77x2	20	0	Y310M770120J1007	Y310M770120J100G
45	20	20	Y3104500220J1007	Y3104500220J100G	M77x2	20	20	Y310M770220J1007	Y310M770220J100G
45	25	0	Y3104500125J1007	Y3104500125J100G	M77x2	25	0	Y310M770125J1007	Y310M770125J100G
45	25	25	Y3104500225J1007	Y3104500225J100G	M77x2	25	25	Y310M770225J1007	Y310M770225J100G
45	M20x1.5	0	Y31045001T0J1007	Y31045001T0J100G	M77x2	M20x1.5	0	Y310M7701T0J1007	Y310M7701T0J100G
45	M20x1.5	M20x1.5	Y31045002T0J1007	Y31045002T0J100G	M77x2	M20x1.5	M20x1.5	Y310M7702T0J1007	Y310M7702T0J100G
45	M25x1.5	0	Y31045001T5J1007	Y31045001T5J100G	M77x2	M25x1.5	0	Y310M7701T5J1007	Y310M7701T5J100G
45	M25x1.5	M25x1.5	Y31045002T5J1007	Y31045002T5J100G	M77x2	M25x1.5	M25x1.5	Y310M7702T5J1007	Y310M7702T5J100G
50	0	0	Y310500000J1007	Y310500000J100G	1½"BSPP	0	0	Y310BA2000J1007	Y310BA2000J100G
50	20	0	Y3105000120J1007	Y3105000120J100G	1½"BSPP	20	0	Y310BA20120 J1007	Y310BA20120 J100G
50	20	20	Y3105000220J1007	Y3105000220J100G	1½"BSPP	20	20	Y310BA20220J1007	Y310BA20220J100G
50	25	0	Y3105000125J1007	Y3105000125J100G	1½"BSPP	25	0	Y310BA20125J1007	Y310BA20125J100G
50	25	25	Y3105000225J1007	Y3105000225J100G	1½"BSPP	25	25	Y310BA20225J1007	Y310BA20225J100G
50	M20x1.5	0	Y31050001T0J1007	Y31050001T0J100G	1½"BSPP	M20x1.5	0	Y310BA201T0J1007	Y310BA201T0J100G
50	M20x1.5	M20x1.5	Y31050002T0J1007	Y31050002T0J100G	1½"BSPP	M20x1.5	M20x1.5	Y310BA202T0J1007	Y310BA202T0J100G
50	M25x1.5	0	Y31050001T5J1007	Y31050001T5J100G	1½"BSPP	M25x1.5	0	Y310BA201T5J1007	Y310BA201T5J100G
50	M25x1.5	M25x1.5	Y31050002T5J1007	Y31050002T5J100G	1½"BSPP	M25x1.5	M25x1.5	Y310BA202T5J1007	Y310BA202T5J100G
60	0	0	Y310600000J1007	Y310600000J100G	2"BSPP	0	0	Y310BB2000J1007	Y310BB2000J100G
60	20	0	Y3106000120J1007	Y3106000120J100G	2"BSPP	20	0	Y310BB20120J1007	Y310BB20120J100G
60	20	20	Y3106000220J1007	Y3106000220J100G	2"BSPP	20	20	Y310BB20220J1007	Y310BB20220J100G
60	25	0	Y3106000125J1007	Y3106000125J100G	2"BSPP	25	0	Y310BB20125J1007	Y310BB20125J100G
60	25	25	Y3106000225J1007	Y3106000225J100G	2"BSPP	25	25	Y310BB20225J1007	Y310BB20225J100G
60	M20x1.5	0	Y31060001T0J1007	Y31060001T0J100G	2"BSPP	M20x1.5	0	Y310BB201T0J1007	Y310BB201T0J100G
60	M20x1.5	M20x1.5	Y31060002T0J1007	Y31060002T0J100G	2"BSPP	M20x1.5	M20x1.5	Y310BB202T0J1007	Y310BB202T0J100G
60	M25x1.5	0	Y31060001T5J1007	Y31060001T5J100G	2"BSPP	M25x1.5	0	Y310BB201T5J1007	Y310BB201T5J100G
60	M25x1.5	M25x1.5	Y31060002T5J1007	Y31060002T5J100G	2"BSPP	M25x1.5	M25x1.5	Y310BB202T5J1007	Y310BB202T5J100G
77	0	0	Y310770000J1007	Y310770000J100G	2½"BSPP	0	0	Y310BC2000J1007	Y310BC2000J100G
77	20	0	Y3107700120J1007	Y3107700120J100G	2½"BSPP	20	0	Y310BC20120J1007	Y310BC20120J100G
77	20	20	Y3107700220J1007	Y3107700220J100G	2½"BSPP	20	20	Y310BC20220 J1007	Y310BC20220J100G
77	25	0	Y3107700125J1007	Y3107700125J100G	2½"BSPP	25	0	Y310BC20125 J1007	Y310BC20125J100G
77	25	25	Y3107700225J1007	Y3107700225J100G	2½"BSPP	25	25	Y310BC20225 J1007	Y310BC20225J100G
77	M20x1.5	0	Y31077001T0J1007	Y31077001T0J100G	2½"BSPP	M20x1.5	0	Y310BC201T0 J1007	Y310BC201T0J100G
77	M20x1.5	M20x1.5	Y31077002T0J1007	Y31077002T0J100G	2½"BSPP	M20x1.5	M20x1.5	Y310BC202T0 J1007	Y310BC202T0 J100G
77	M25x1.5	0	Y31077001T5J1007	Y31077001T5J100G	2½"BSPP	M25x1.5	0	Y310BC201T5 J1007	Y310BC201T5J100G
77	M25x1.5	M25x1.5	Y31077002T5J1007	Y31077002T5J100G	2½"BSPP	M25x1.5	M25x1.5	Y310BC202T5 J1007	Y310BC202T5J100G

Because of permanent improvement of our products, drawings, descriptions, features used on these data sheets are for guidance only and can be modified without prior advice



# Immersion heaters fitting

**The references given in these documents are the most common.**

**The dotted areas in the plans indicate the options.**

Fittings can be made in 304 and 316 stainless steel, brass or PPS. Diameters and threads are of the metric system. **USA or UK dimensions can be made on request**



# Stainless steel fitting, with 3 screws rotating ring, deep drawn body and machined thread, for medium corrosive environments.

Minimum Size	Maximum Size	Material	Type	Model
1" ½	2" ½	Stainless steel	Rotation ring and welded cup	<b>66RJ (304L)</b> <b>66RU (316L)</b>

Compatible accessories			
<input checked="" type="checkbox"/> 66JE	<input checked="" type="checkbox"/> 66XF		
<input checked="" type="checkbox"/> 66JF	<input checked="" type="checkbox"/> 66Z1		
<input checked="" type="checkbox"/> 66JP	<input checked="" type="checkbox"/> 66Z2		
<input checked="" type="checkbox"/> 66NL			

Compatible enclosures			
<input checked="" type="checkbox"/> Y302	<input checked="" type="checkbox"/> Y3C1	<input checked="" type="checkbox"/> Y3J2	<input checked="" type="checkbox"/> Y3P1
<input checked="" type="checkbox"/> Y303	<input checked="" type="checkbox"/> Y3C3	<input checked="" type="checkbox"/> Y3K1	<input checked="" type="checkbox"/> Y3P3
<input checked="" type="checkbox"/> Y304	<input checked="" type="checkbox"/> Y3C4	<input checked="" type="checkbox"/> Y3K2	<input checked="" type="checkbox"/> Y3P4
<input checked="" type="checkbox"/> Y305	<input checked="" type="checkbox"/> Y3G1	<input checked="" type="checkbox"/> Y3L3	<input checked="" type="checkbox"/> Y3P5
<input checked="" type="checkbox"/> Y306	<input checked="" type="checkbox"/> Y3G2	<input checked="" type="checkbox"/> Y3M1	<input checked="" type="checkbox"/> Y3P6
<input checked="" type="checkbox"/> Y307	<input checked="" type="checkbox"/> Y3H1	<input checked="" type="checkbox"/> Y3N1	<input checked="" type="checkbox"/> Y3S3
<input checked="" type="checkbox"/> Y309	<input checked="" type="checkbox"/> Y3H2	<input checked="" type="checkbox"/> Y3N2	<input checked="" type="checkbox"/> Y3S5
<input checked="" type="checkbox"/> Y310	<input checked="" type="checkbox"/> Y3H3	<input checked="" type="checkbox"/> Y3N3	<input checked="" type="checkbox"/> Y3S7
<input checked="" type="checkbox"/> Y3B2	<input checked="" type="checkbox"/> Y3J1	<input checked="" type="checkbox"/> Y3N4	<input checked="" type="checkbox"/> Y3SA

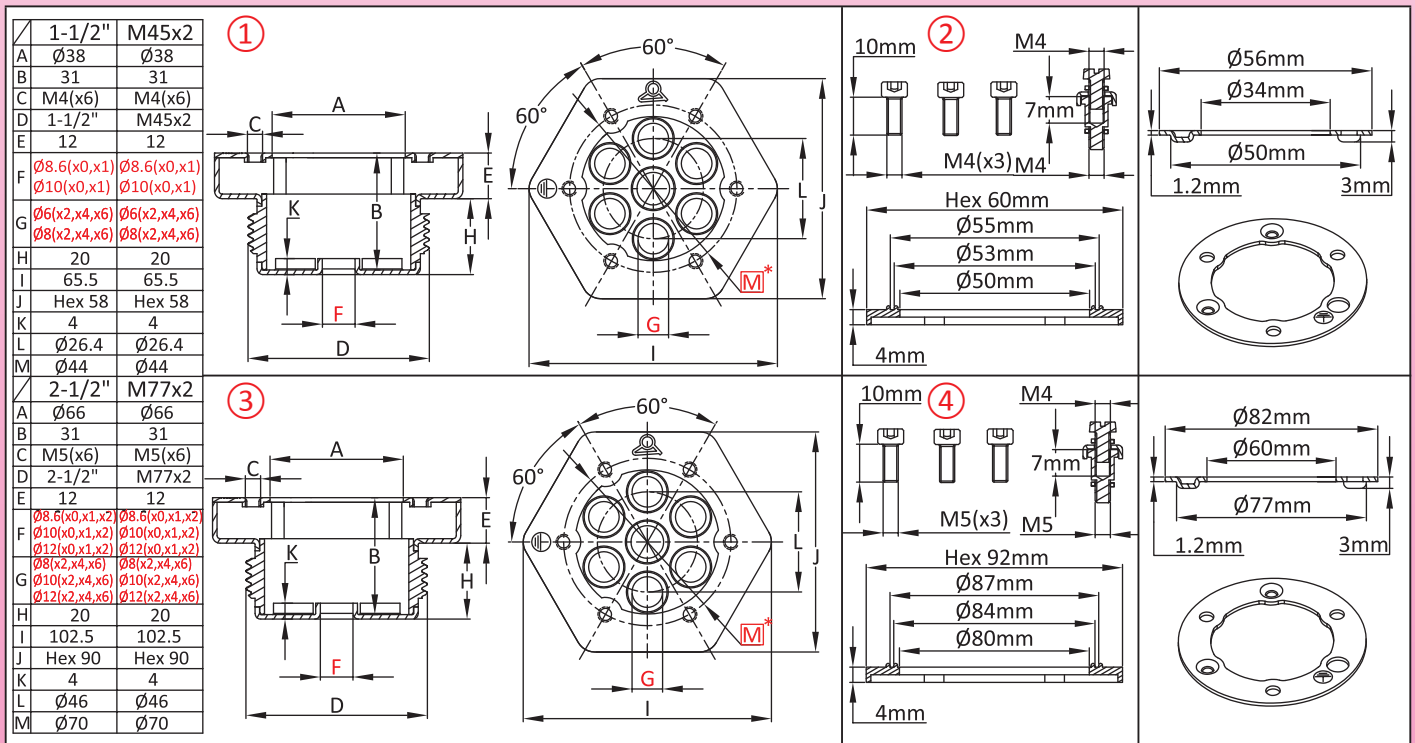

### Main references

Dimensions	Composition	Reference in AISI 304L	Reference in AISI 316L
1½"	①	66RJA3T*****0000	66RUA3T*****0000
1½"	①+②	66RJA3T*****0005	66RUA3T*****0005
M45x2	①	66RJMDT*****0000	66RUMDT*****0000
M45x2	①+②	66RJMDT*****0005	66RUMDT*****0005
2½"	③	66RJA7T*****0000	66RUA7T*****0000
2½"	③+④	66RJA7T*****0005	66RUA7T*****0005
M77x2	③	66RJMGT*****0000	66RUMGT*****0000
M77x2	③+④	66RJMGT*****0005	66RUMGT*****0005

### Links



Page  
(.pdf)



Drawing 2D  
(.dwg)



Drawing 3D  
(.stp)

Specify dimensions and quantity of holes F and G.  
Red dimensions inside rectangular frames are used for assembly on enclosures or on fittings.

**Stainless steel fitting with 3 screws stamped rotation ring, with deep drawn body and machined thread, for medium corrosive environments. Non-welded heating elements flange**

Minimum Size	Maximum Size	Material	Type	Model
1" ½	2" ½	Stainless steel	Rotation ring+ un-welded cup	<b>66RK (304L) 66RV (316L)</b>

Compatible accessories			
<input checked="" type="checkbox"/> 66JE	<input checked="" type="checkbox"/> 66XF		
<input checked="" type="checkbox"/> 66JF	<input checked="" type="checkbox"/> 66Z1		
<input checked="" type="checkbox"/> 66JP	<input checked="" type="checkbox"/> 66Z2		
<input checked="" type="checkbox"/> 66NL			

Compatible enclosures			
<input checked="" type="checkbox"/> Y302	<input checked="" type="checkbox"/> Y3C1	<input checked="" type="checkbox"/> Y3J2	<input checked="" type="checkbox"/> Y3P1
<input checked="" type="checkbox"/> Y303	<input checked="" type="checkbox"/> Y3C3	<input checked="" type="checkbox"/> Y3K1	<input checked="" type="checkbox"/> Y3P3
<input checked="" type="checkbox"/> Y304	<input checked="" type="checkbox"/> Y3C4	<input checked="" type="checkbox"/> Y3K2	<input checked="" type="checkbox"/> Y3P4
<input checked="" type="checkbox"/> Y305	<input checked="" type="checkbox"/> Y3G1	<input checked="" type="checkbox"/> Y3L3	<input checked="" type="checkbox"/> Y3P5
<input checked="" type="checkbox"/> Y306	<input checked="" type="checkbox"/> Y3G2	<input checked="" type="checkbox"/> Y3M1	<input checked="" type="checkbox"/> Y3P6
<input checked="" type="checkbox"/> Y307	<input checked="" type="checkbox"/> Y3H1	<input checked="" type="checkbox"/> Y3N1	<input checked="" type="checkbox"/> Y3S3
<input checked="" type="checkbox"/> Y309	<input checked="" type="checkbox"/> Y3H2	<input checked="" type="checkbox"/> Y3N2	<input checked="" type="checkbox"/> Y3S5
<input checked="" type="checkbox"/> Y310	<input checked="" type="checkbox"/> Y3H3	<input checked="" type="checkbox"/> Y3N3	<input checked="" type="checkbox"/> Y3S7
<input checked="" type="checkbox"/> Y3B2	<input checked="" type="checkbox"/> Y3J1	<input checked="" type="checkbox"/> Y3N4	<input checked="" type="checkbox"/> Y3SA

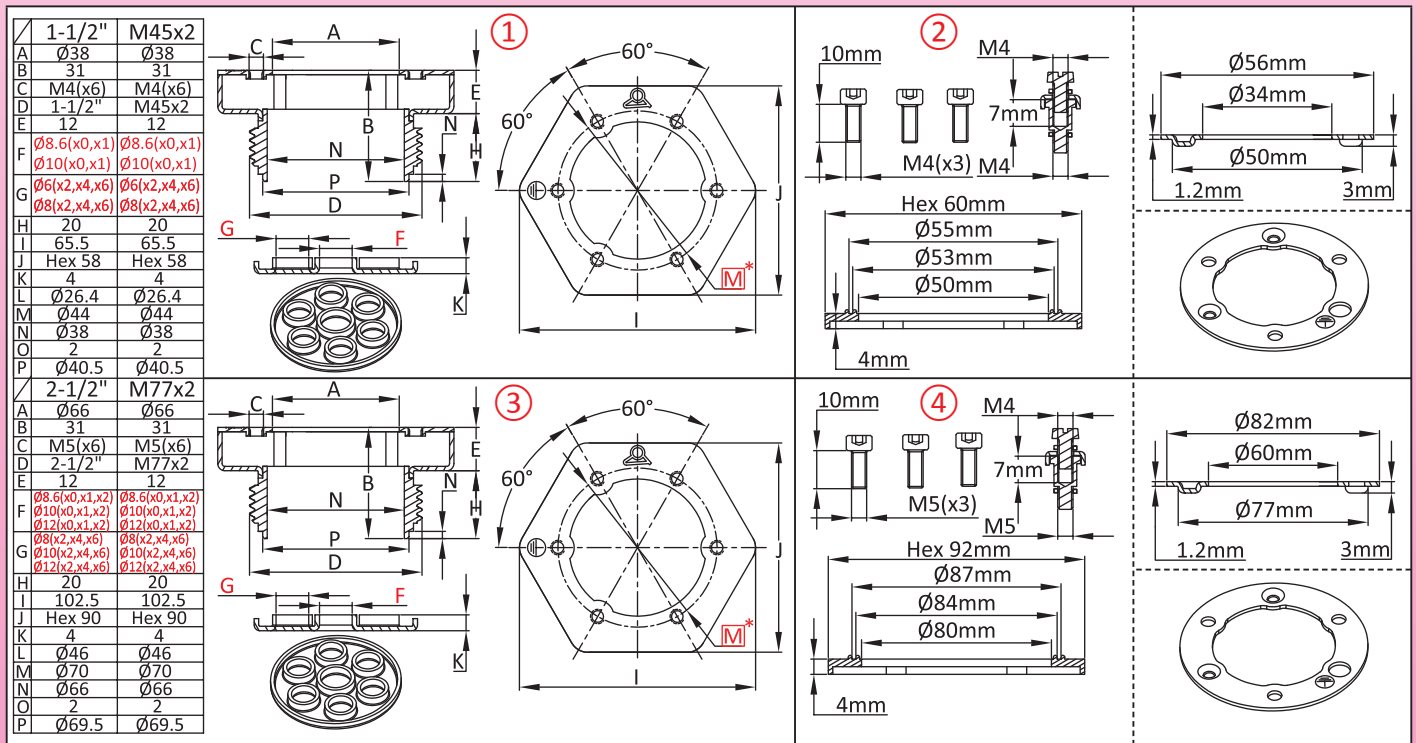

**Main references**

Dimensions	Composition	Reference in AISI 304L	Reference in AISI 316L
1½"	①	66RKA3T*****0000	66RVA3T*****0000
1½"	①+②	66RKA3T*****0005	66RVA3T*****0005
M45x2	①	66RKMDT*****0000	66RVMDT*****0000
M45x2	①+②	66RKMDT*****0005	66RVMDT*****0005
2½"	③	66RKA7T*****0000	66RVA7T*****0000
2½"	③+④	66RKA7T*****0005	66RVA7T*****0005
M77x2	③	66RKMGT*****0000	66RVMG T*****0000
M77x2	③+④	66RKMGT*****0005	66RVMG T*****0005

**Links**

Page (.pdf)

Drawing 2D (.dwg)

Drawing 3D (.stp)

Specify dimensions and quantity of holes F and G.  
Red dimensions inside rectangular frames are used for assembly on enclosures or on fittings.



# Stainless steel fitting with 3 screws stamped rotation ring, with deep drawn body and massive machined thread, for medium corrosive environments.

Minimum Size	Maximum Size	Material	Type	Model
1" ½	2" ½	Stainless steel	Rotation ring and massive thread	<b>66RO (304L)</b> <b>66RP (316L)</b>

Compatible accessories			
<input checked="" type="checkbox"/> 66JE	<input checked="" type="checkbox"/> 66XF		
<input checked="" type="checkbox"/> 66JF	<input checked="" type="checkbox"/> 66Z1		
<input checked="" type="checkbox"/> 66JP	<input checked="" type="checkbox"/> 66Z2		
<input checked="" type="checkbox"/> 66NL			

Compatible enclosures			
<input checked="" type="checkbox"/> Y302	<input checked="" type="checkbox"/> Y3C1	<input checked="" type="checkbox"/> Y3J2	<input checked="" type="checkbox"/> Y3P1
<input checked="" type="checkbox"/> Y303	<input checked="" type="checkbox"/> Y3C3	<input checked="" type="checkbox"/> Y3K1	<input checked="" type="checkbox"/> Y3P3
<input checked="" type="checkbox"/> Y304	<input checked="" type="checkbox"/> Y3C4	<input checked="" type="checkbox"/> Y3K2	<input checked="" type="checkbox"/> Y3P4
<input checked="" type="checkbox"/> Y305	<input checked="" type="checkbox"/> Y3G1	<input checked="" type="checkbox"/> Y3L3	<input checked="" type="checkbox"/> Y3P5
<input checked="" type="checkbox"/> Y306	<input checked="" type="checkbox"/> Y3G2	<input checked="" type="checkbox"/> Y3M1	<input checked="" type="checkbox"/> Y3P6
<input checked="" type="checkbox"/> Y307	<input checked="" type="checkbox"/> Y3H1	<input checked="" type="checkbox"/> Y3N1	<input checked="" type="checkbox"/> Y3S3
<input checked="" type="checkbox"/> Y309	<input checked="" type="checkbox"/> Y3H2	<input checked="" type="checkbox"/> Y3N2	<input checked="" type="checkbox"/> Y3S5
<input checked="" type="checkbox"/> Y310	<input checked="" type="checkbox"/> Y3H3	<input checked="" type="checkbox"/> Y3N3	<input checked="" type="checkbox"/> Y3S7
<input checked="" type="checkbox"/> Y3B2	<input checked="" type="checkbox"/> Y3J1	<input checked="" type="checkbox"/> Y3N4	<input checked="" type="checkbox"/> Y3SA

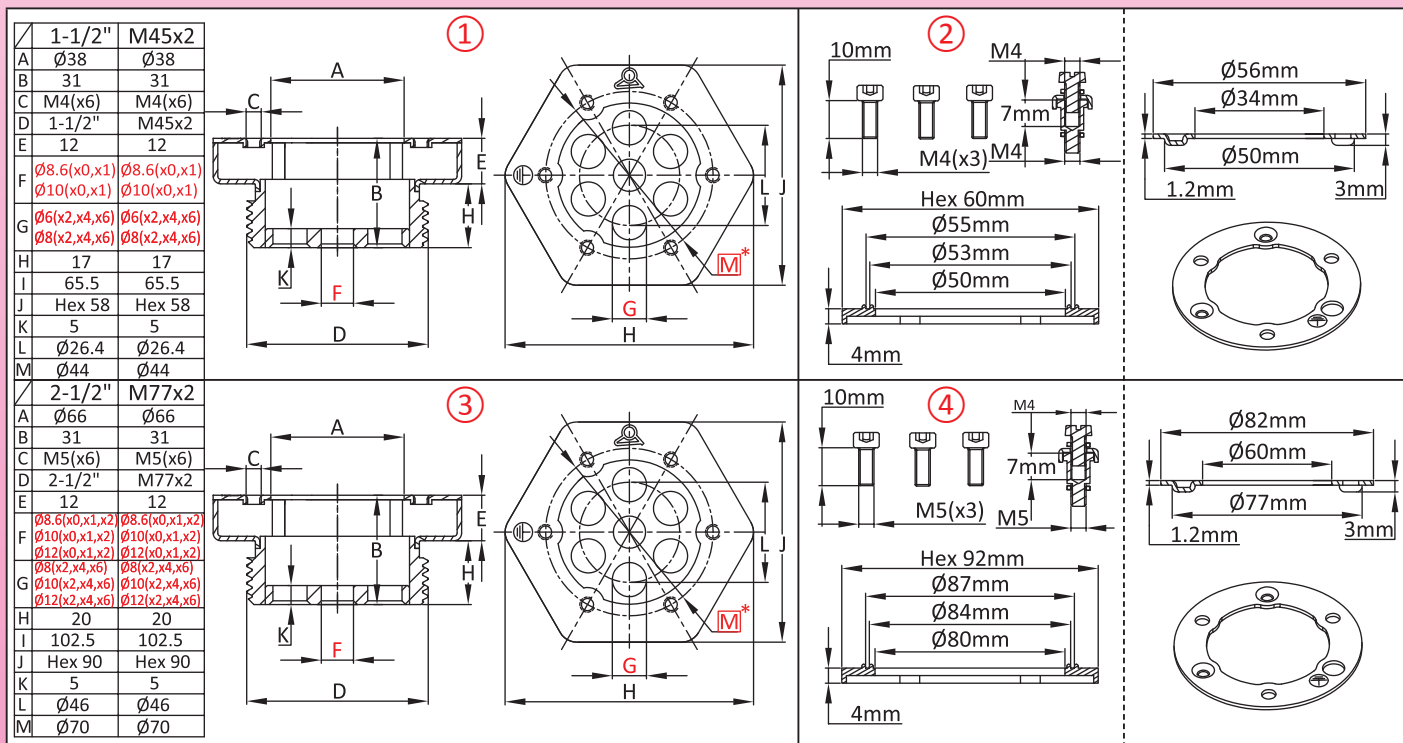
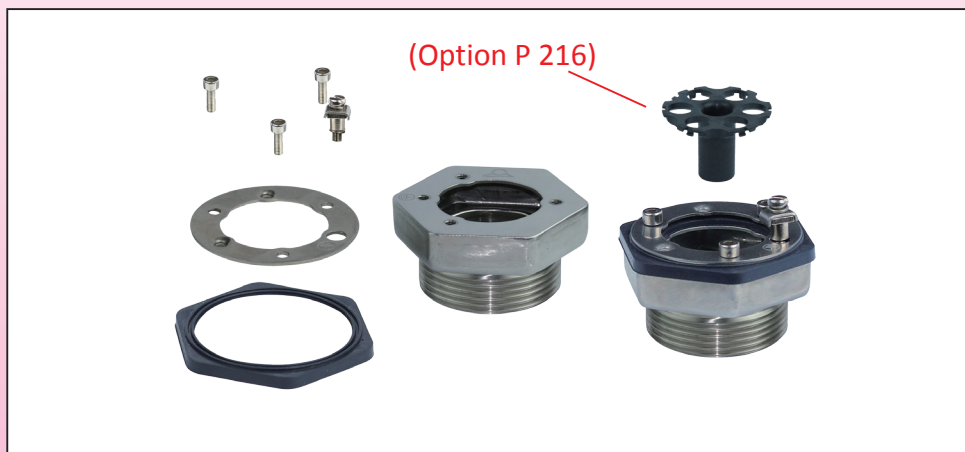

## Main references

Dimensions	Composition	Reference in AISI 304L	Reference in AISI 316L
1½"	①	66ROA3T*****0000	66RPA3T*****0000
1½"	①+②	66ROA3T*****0005	66RPA3T*****0005
M45x2	①	66ROMDT*****0000	66RPMDT*****0000
M45x2	①+②	66ROMDT*****0005	66RPMDT*****0005
2½"	③	66ROA7T*****0000	66RPA7T*****0000
2½"	③+④	66ROA7T*****0005	66RPA7T*****0005
M77x2	③	66ROMGT*****0000	66RPMGT*****0000
M77x2	③+④	66ROMGT*****0005	66RPMGT*****0005

## Links



Page  
(.pdf)



Drawing 2D  
(.dwg)



Drawing 3D  
(.stp)

Specify dimensions and quantity of holes F and G.

Red dimensions inside rectangular frames are used for assembly on enclosures or on fittings.

**Stainless steel fitting with 3 screws stamped rotation ring, with deep drawn body and massive machined thread, for medium corrosive environments. Non-welded thread**

Minimum Size	Maximum Size	Material	Type	Model
1" ½	2" ½	Stainless steel	Rotation ring and non-welded massive thread	<b>66RQ (304L)</b> <b>66RR (316L)</b>

Compatible accessories			
<input checked="" type="checkbox"/> 66JE	<input checked="" type="checkbox"/> 66XF		
<input checked="" type="checkbox"/> 66JF	<input checked="" type="checkbox"/> 66Z1		
<input checked="" type="checkbox"/> 66JP	<input checked="" type="checkbox"/> 66Z2		
<input checked="" type="checkbox"/> 66NL			

Compatible enclosures			
<input checked="" type="checkbox"/> Y302	<input checked="" type="checkbox"/> Y3C1	<input checked="" type="checkbox"/> Y3J2	<input checked="" type="checkbox"/> Y3P1
<input checked="" type="checkbox"/> Y303	<input checked="" type="checkbox"/> Y3C3	<input checked="" type="checkbox"/> Y3K1	<input checked="" type="checkbox"/> Y3P3
<input checked="" type="checkbox"/> Y304	<input checked="" type="checkbox"/> Y3C4	<input checked="" type="checkbox"/> Y3K2	<input checked="" type="checkbox"/> Y3P4
<input checked="" type="checkbox"/> Y305	<input checked="" type="checkbox"/> Y3G1	<input checked="" type="checkbox"/> Y3L3	<input checked="" type="checkbox"/> Y3P5
<input checked="" type="checkbox"/> Y306	<input checked="" type="checkbox"/> Y3G2	<input checked="" type="checkbox"/> Y3M1	<input checked="" type="checkbox"/> Y3P6
<input checked="" type="checkbox"/> Y307	<input checked="" type="checkbox"/> Y3H1	<input checked="" type="checkbox"/> Y3N1	<input checked="" type="checkbox"/> Y3S3
<input checked="" type="checkbox"/> Y309	<input checked="" type="checkbox"/> Y3H2	<input checked="" type="checkbox"/> Y3N2	<input checked="" type="checkbox"/> Y3S5
<input checked="" type="checkbox"/> Y310	<input checked="" type="checkbox"/> Y3H3	<input checked="" type="checkbox"/> Y3N3	<input checked="" type="checkbox"/> Y3S7
<input checked="" type="checkbox"/> Y3B2	<input checked="" type="checkbox"/> Y3J1	<input checked="" type="checkbox"/> Y3N4	<input checked="" type="checkbox"/> Y3SA

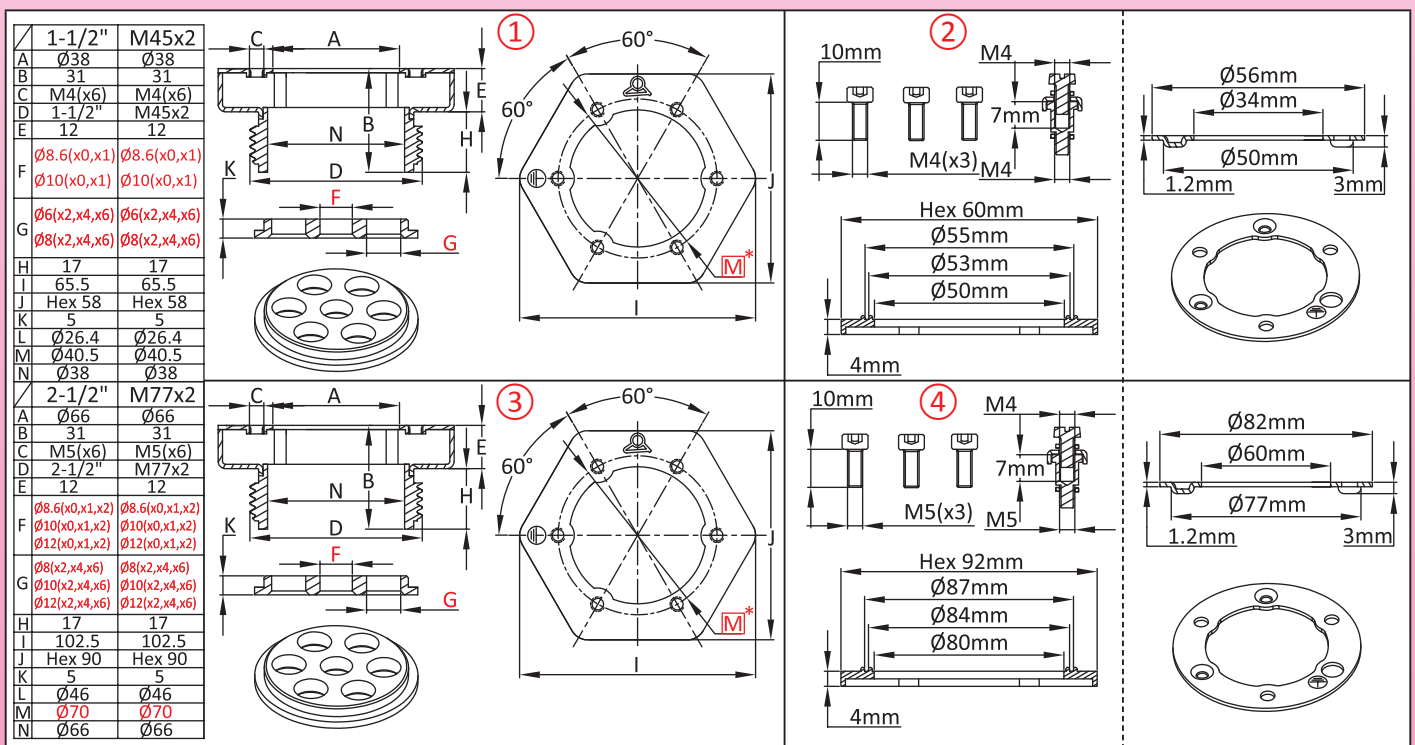

**Main references**

Dimensions	Composition	Reference in AISI 304L	Reference in AISI 316L
1½"	①	66RQA3T*****0000	66RRA3T*****0000
1½"	①+②	66RQA3T*****0005	66RRA3T*****0005
M45x2	①	66RQMDT*****0000	66RRMDT*****0000
M45x2	①+②	66RQMDT*****0005	66RRMDT*****0005
2½"	③	66RQA7T*****0000	66RRA7T*****0000
2½"	③+④	66RQA7T*****0005	66RRA7T*****0005
M77x2	③	66RQMGT*****0000	66RRMGT*****0000
M77x2	③+④	66RQMGT*****0005	66RRMGT*****0005

**Links**

[Page \(.pdf\)](#)

[Drawing 2D \(.dwg\)](#)

[Drawing 3D \(.stp\)](#)

Specify dimensions and quantity of holes F and G.  
Red dimensions inside rectangular frames are used for assembly on enclosures or on fittings.

Because of permanent improvement of our products, drawings, descriptions, features used on these data sheets are for guidance only and can be modified without prior advice

# Stainless steel fitting with wide rotating flange, welded thread and heating elements flange

Minimum Size	Maximum Size	Material	Type	Model
1" 1/2	M45x2	Stainless steel	- Big deep drawn flange - Welded cup	<b>66R2 (304L)</b> <b>66R6 (316L)</b>

Compatible accessories	
<input checked="" type="checkbox"/> 66JF	
<input checked="" type="checkbox"/> 66JP	
<input checked="" type="checkbox"/> 66JR	
<input checked="" type="checkbox"/> 66NL	
<input checked="" type="checkbox"/> 66XF	
Compatible enclosures	
<input checked="" type="checkbox"/> Y309	<input checked="" type="checkbox"/> Y3J2
<input checked="" type="checkbox"/> Y310	<input checked="" type="checkbox"/> Y3M1
<input checked="" type="checkbox"/> Y3G1	<input checked="" type="checkbox"/> Y3P5
<input checked="" type="checkbox"/> Y3G2	<input checked="" type="checkbox"/> Y3S7
<input checked="" type="checkbox"/> Y3G3	<input checked="" type="checkbox"/> Y3SA
<input checked="" type="checkbox"/> Y3J1	



	1-1/2"	M45x2
A	Ø90	Ø90
B	Ø84	Ø84
C	M4(x3)	M4(x3)
D	1-1/2"	M45x2
E	8	8
F	Ø8.6(x0,x1) Ø10(x0,x1)	Ø8.6(x0,x1) Ø10(x0,x1)
G	Ø6(x2,x4,x6) Ø8(x2,x4,x6)	Ø6(x2,x4,x6) Ø8(x2,x4,x6)
H	13.5	13.5
I	M4	M4
J	20	20
K	Ø70	Ø70
L	Hex 58	Hex 58
M	Ø3	Ø3

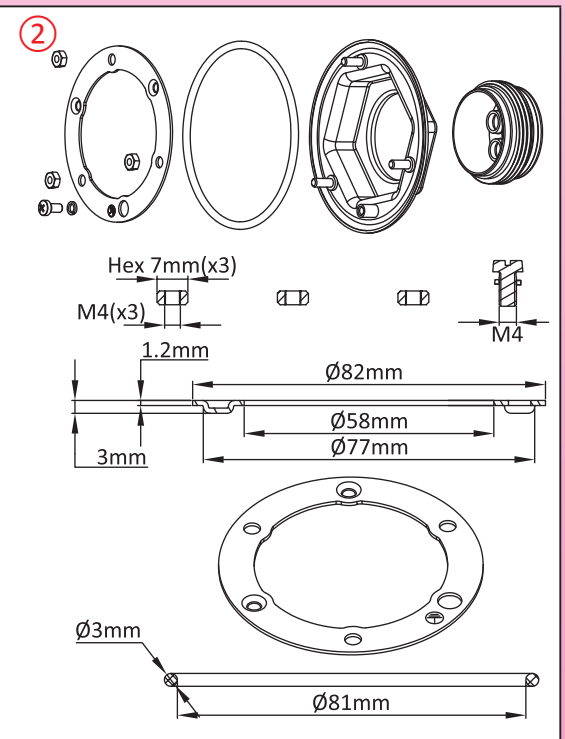
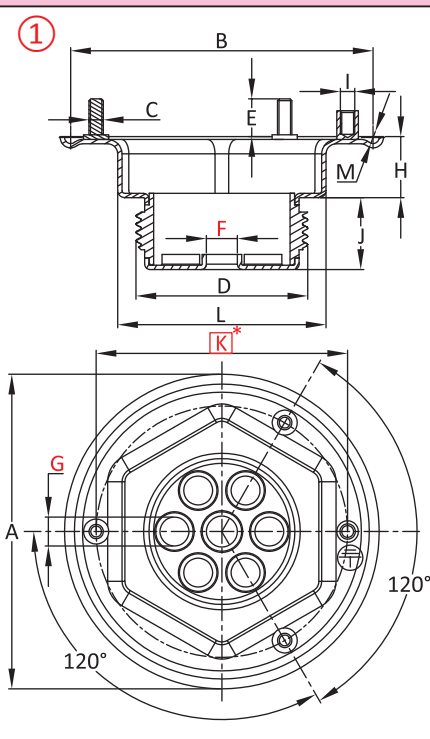

## Main references

Dimensions	Composition	Reference in AISI 304L	Reference in AISI 316L
1 1/2"	①	66R2A3T*****0000	66R6A3T*****0000
1 1/2"	①+②	66R2A3T*****0005	66R6A3T*****0005
M45x2	①	66R2MDT*****0000	66R6MDT*****0000
M45x2	①+②	66R2MDT*****0005	66R6MDT*****0005

## Links

	Page (.pdf)
	Drawing 2D (.dwg)
	Drawing 3D (.stp)

Specify dimensions and quantity of holes F and G.  
Red dimensions inside rectangular frames are used for assembly on enclosures or on fittings.

# Stainless steel fitting with wide rotating flange, welded thread, non-welded heating elements flange

Minimum Size	Maximum Size	Material	Type	Model
1" ½	M45x2	Stainless steel	- Big deep drawn flange - Non-welded cup	<b>66R3 (304L)</b> <b>66R7 (316L)</b>

Compatible accessories	
<input checked="" type="checkbox"/> 66JF	
<input checked="" type="checkbox"/> 66JP	
<input checked="" type="checkbox"/> 66JR	
<input checked="" type="checkbox"/> 66NL	
<input checked="" type="checkbox"/> 66XF	
Compatible enclosures	
<input checked="" type="checkbox"/> Y309	<input checked="" type="checkbox"/> Y3J2
<input checked="" type="checkbox"/> Y310	<input checked="" type="checkbox"/> Y3M1
<input checked="" type="checkbox"/> Y3G1	<input checked="" type="checkbox"/> Y3P5
<input checked="" type="checkbox"/> Y3G2	<input checked="" type="checkbox"/> Y3S7
<input checked="" type="checkbox"/> Y3G3	<input checked="" type="checkbox"/> Y3SA
<input checked="" type="checkbox"/> Y3J1	



	1-1/2"	M45x2
A	Ø90	Ø90
B	Ø84	Ø84
C	M4(x3)	M4(x3)
D	1-1/2"	M45x2
E	8	8
F	Ø8.6(x0,x1) Ø10(x0,x1)	Ø8.6(x0,x1) Ø10(x0,x1)
G	Ø6(x2,x4,x6) Ø8(x2,x4,x6)	Ø6(x2,x4,x6) Ø8(x2,x4,x6)
H	13.5	13.5
I	M4	M4
J	20	20
K	Ø70	Ø70
L	Hex 58	Hex 58
M	Ø3	Ø3
N	Ø40.5	Ø40.5

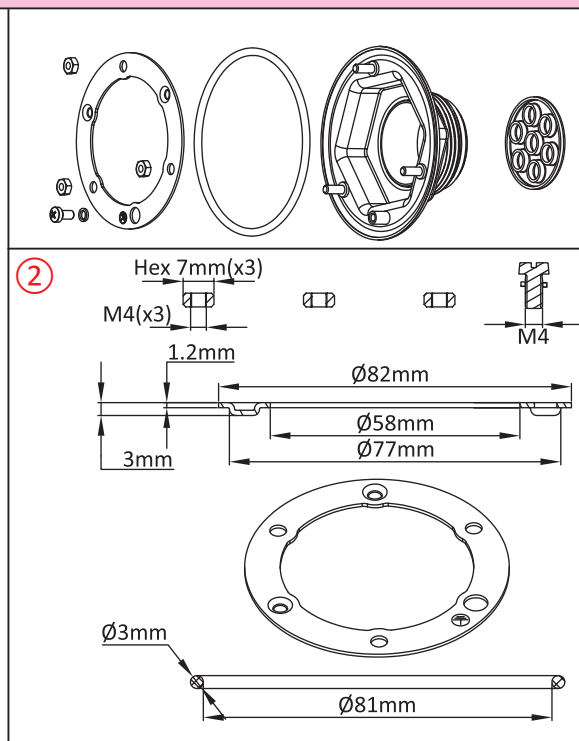
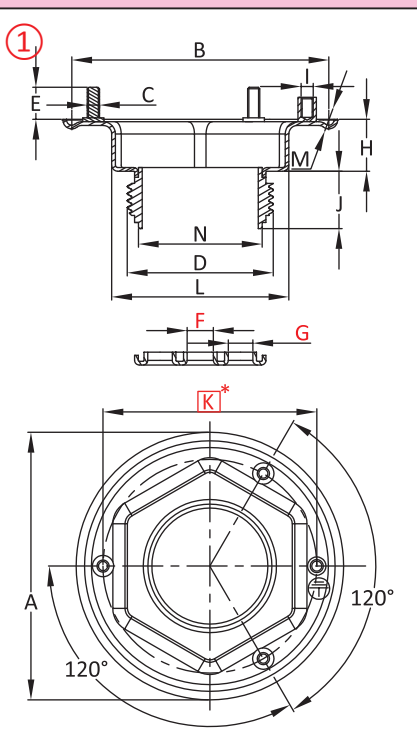

## Main references

Dimensions	Composition	Reference in AISI 304L	Reference in AISI 316L
1½"	①	66R3A3T*****0000	66R7A3T*****0000
1½"	①+②	66R3A3T*****0005	66R7A3T*****0005
M45x2	①	66R3MDT*****0000	66R7MDT*****0000
M45x2	①+②	66R3MDT*****0005	66R7MDT*****0005

## Links

	Page (.pdf)
	Drawing 2D (.dwg)
	Drawing 3D (.stp)

Specify dimensions and quantity of holes F and G.  
Red dimensions inside rectangular frames are used for assembly on enclosures or on fittings.

# Stainless steel fitting with wide rotating flange, welded massive thread

Minimum Size	Maximum Size	Material	Type	Model
1" ½	M45x2	Stainless steel	- Big deep drawn flange - Massive welded thread	<b>66R4 (304L)</b> <b>66R8 (316L)</b>

Compatible accessories	
<input checked="" type="checkbox"/> 66JF	
<input checked="" type="checkbox"/> 66JP	
<input checked="" type="checkbox"/> 66JR	
<input checked="" type="checkbox"/> 66NL	
<input checked="" type="checkbox"/> 66XF	
Compatible enclosures	
<input checked="" type="checkbox"/> Y309	
<input checked="" type="checkbox"/> Y310	
<input checked="" type="checkbox"/> Y3G1	
<input checked="" type="checkbox"/> Y3G2	
<input checked="" type="checkbox"/> Y3G3	
<input checked="" type="checkbox"/> Y3J1	
<input checked="" type="checkbox"/> Y3J2	
<input checked="" type="checkbox"/> Y3M1	
<input checked="" type="checkbox"/> Y3P5	
<input checked="" type="checkbox"/> Y3S7	
<input checked="" type="checkbox"/> Y3SA	



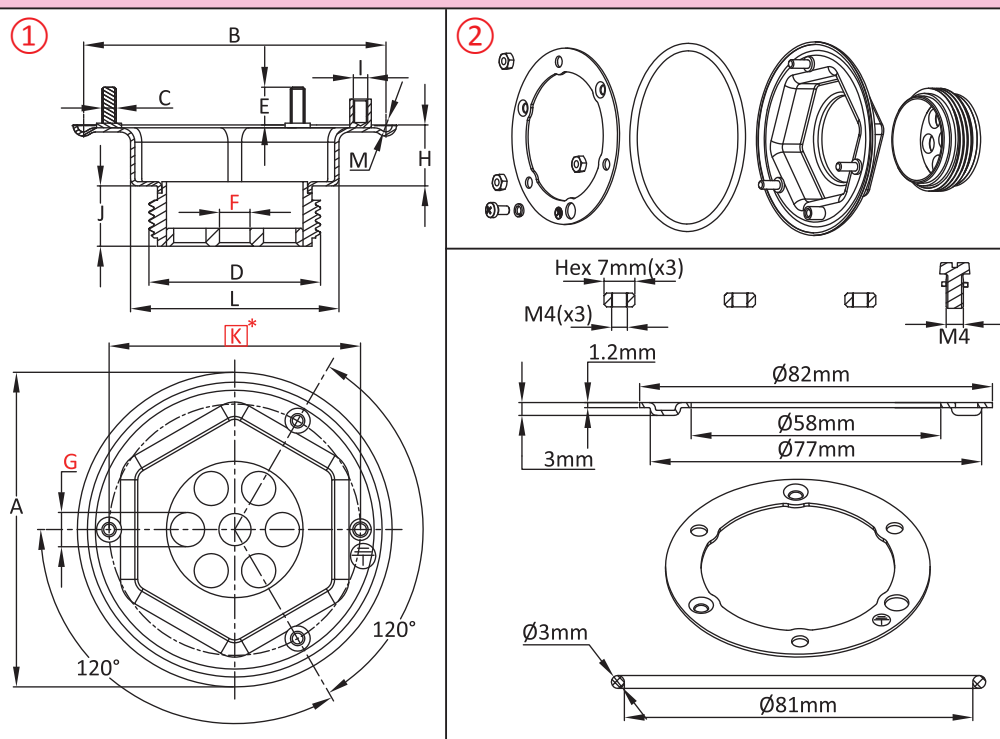

	1-1/2"	M45x2
A	Ø90	Ø90
B	Ø84	Ø84
C	M4(x3)	M4(x3)
D	1-1/2"	M45x2
E	8	8
F	Ø8.6(x0,x1) Ø10(x0,x1)	Ø8.6(x0,x1) Ø10(x0,x1)
G	Ø6(x2,x4,x6) Ø8(x2,x4,x6)	Ø6(x2,x4,x6) Ø8(x2,x4,x6)
H	13.5	13.5
I	M4	M4
J	20	20
K	Ø70	Ø70
L	Hex 58	Hex 58
M	Ø3	Ø3



## Main references

Dimensions	Composition	Reference in AISI 304L	Reference in AISI 316L
1½"	①	66R4A3T*****0000	66R8A3T*****0000
1½"	①+②	66R4A3T*****0005	66R8A3T*****0005
M45x2	①	66R4MDT*****0000	66R8MDT*****0000
M45x2	①+②	66R4MDT*****0005	66R8MDT*****0005

## Links

	Page (.pdf)
	Drawing 2D (.dwg)
	Drawing 3D (.stp)

Specify dimensions and quantity of holes F and G.  
Red dimensions inside rectangular frames are used for assembly on enclosures or on fittings.

# Stainless steel fitting with wide rotating flange, non-welded massive thread

Minimum Size	Maximum Size	Material	Type	Model
1" ½	M45x2	Stainless steel	- Big deep drawn flange - Massive welded thread	<b>66R5 (304L)</b> <b>66R9 (316L)</b>

Compatible accessories	
<input checked="" type="checkbox"/> 66JF	
<input checked="" type="checkbox"/> 66JP	
<input checked="" type="checkbox"/> 66JR	
<input checked="" type="checkbox"/> 66NL	
<input checked="" type="checkbox"/> 66XF	
Compatible enclosures	
<input checked="" type="checkbox"/> Y309	<input checked="" type="checkbox"/> Y3J2
<input checked="" type="checkbox"/> Y310	<input checked="" type="checkbox"/> Y3M1
<input checked="" type="checkbox"/> Y3G1	<input checked="" type="checkbox"/> Y3P5
<input checked="" type="checkbox"/> Y3G2	<input checked="" type="checkbox"/> Y3S7
<input checked="" type="checkbox"/> Y3G3	<input checked="" type="checkbox"/> Y3SA
<input checked="" type="checkbox"/> Y3J1	



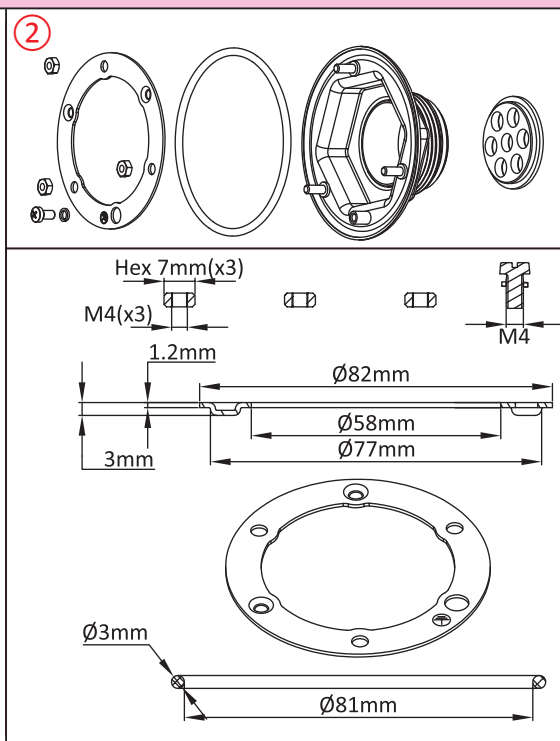
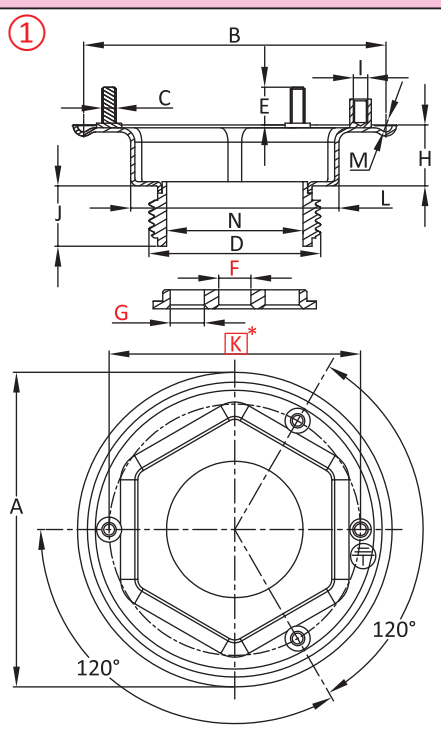

	1-1/2"	M45x2
A	Ø90	Ø90
B	Ø84	Ø84
C	M4(x3)	M4(x3)
D	1-1/2"	M45x2
E	8	8
F	Ø8.6(x0,x1) Ø10(x0,x1)	Ø8.6(x0,x1) Ø10(x0,x1)
G	Ø6(x2,x4,x6) Ø8(x2,x4,x6)	Ø6(x2,x4,x6) Ø8(x2,x4,x6)
H	13.5	13.5
I	M4	M4
J	20	20
K	Ø70	Ø70
L	Hex 58	Hex 58
M	Ø3	Ø3
N	Ø38	Ø38



## Main references

Dimensions	Composition	Reference in AISI 304L	Reference in AISI 316L
1½"	①	66R5A3T*****0000	66R9A3T*****0000
1½"	①+②	66R5A3T*****0005	66R9A3T*****0005
M45x2	①	66R5MDT*****0000	66R9MDT*****0000
M45x2	①+②	66R5MDT*****0005	66R9MDT*****0005

## Links

	Page (.pdf)
	Drawing 2D (.dwg)
	Drawing 3D (.stp)

Specify dimensions and quantity of holes F and G.  
Red dimensions inside rectangular frames are used for assembly on enclosures or on fittings.

## 2" plastic fittings for corrosive liquids like swimming pool, spas and aquariums waters. Without built-in pockets

Minimum Size	Maximum Size	Material	Type	Model
2"	2"	PPS	Compression gasket fitting	<b>66RW</b>

Compatible accessories		
<input checked="" type="checkbox"/> 66XF		
<input checked="" type="checkbox"/> 66JF		
<input checked="" type="checkbox"/> 66JP		
<input checked="" type="checkbox"/> 66NS		
Compatible enclosures		
<input checked="" type="checkbox"/> Y305	<input checked="" type="checkbox"/> Y3P6	<input checked="" type="checkbox"/> Y3S7
<input checked="" type="checkbox"/> Y3P3	<input checked="" type="checkbox"/> Y3S5	<input checked="" type="checkbox"/> Y3C2
<input checked="" type="checkbox"/> Y3P5	<input checked="" type="checkbox"/> Y3SA	<input checked="" type="checkbox"/> Y306

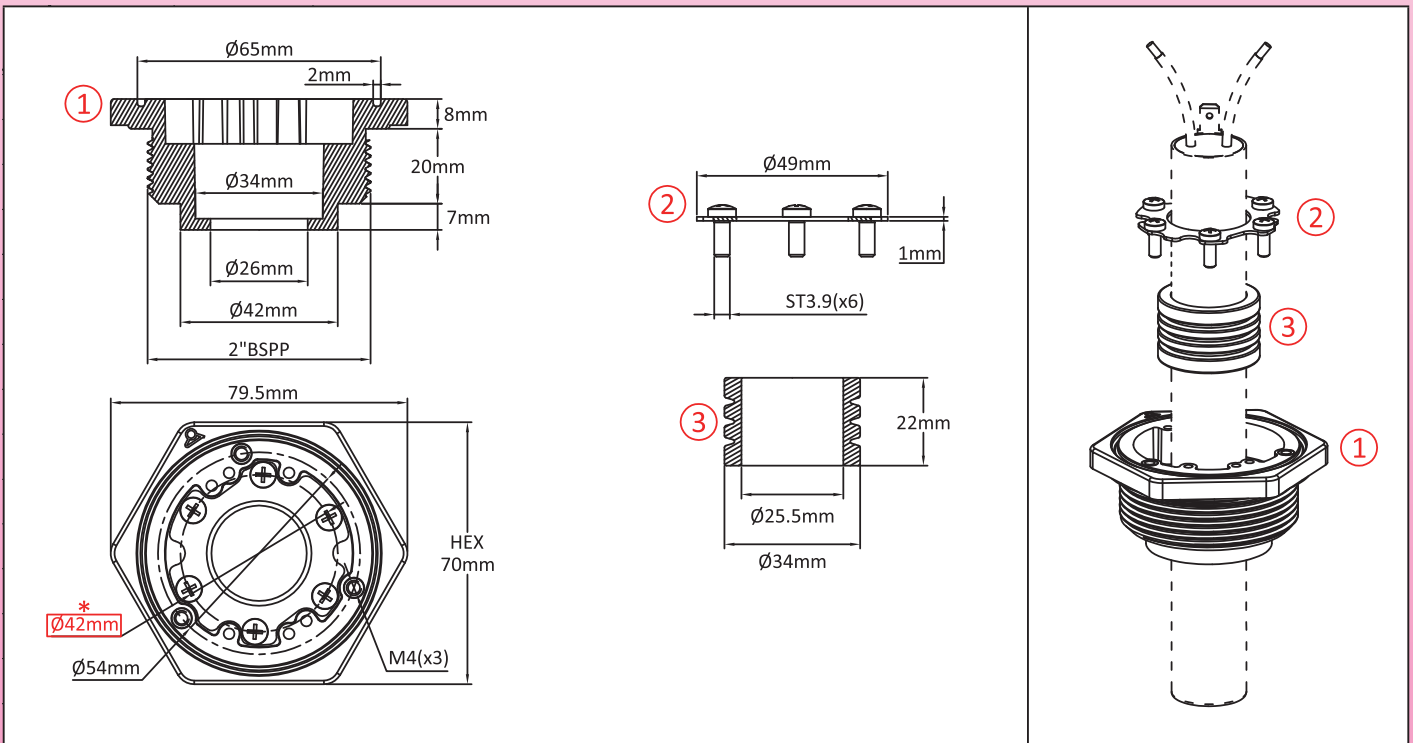

### References

①	
66RWA5T026000000	
①+②+③	
③=Silicone	66RWA5T026000006
③=FKM	66RWA5T026000008
③=NBR	66RWA5T026000007

### Links

	Page (.pdf)
	Drawing 2D (.dwg)
	Drawing 3D (.stp)

Red dimensions inside rectangular frames are used for assembly on enclosures or on fittings.

## 2" plastic fittings for corrosive liquids like swimming pool, spas and aquariums waters. With built-in pockets

Minimum Size	Maximum Size	Material	Type	Model
2"	2"	PPS	Compression gasket fitting with pockets	<b>66RY</b>

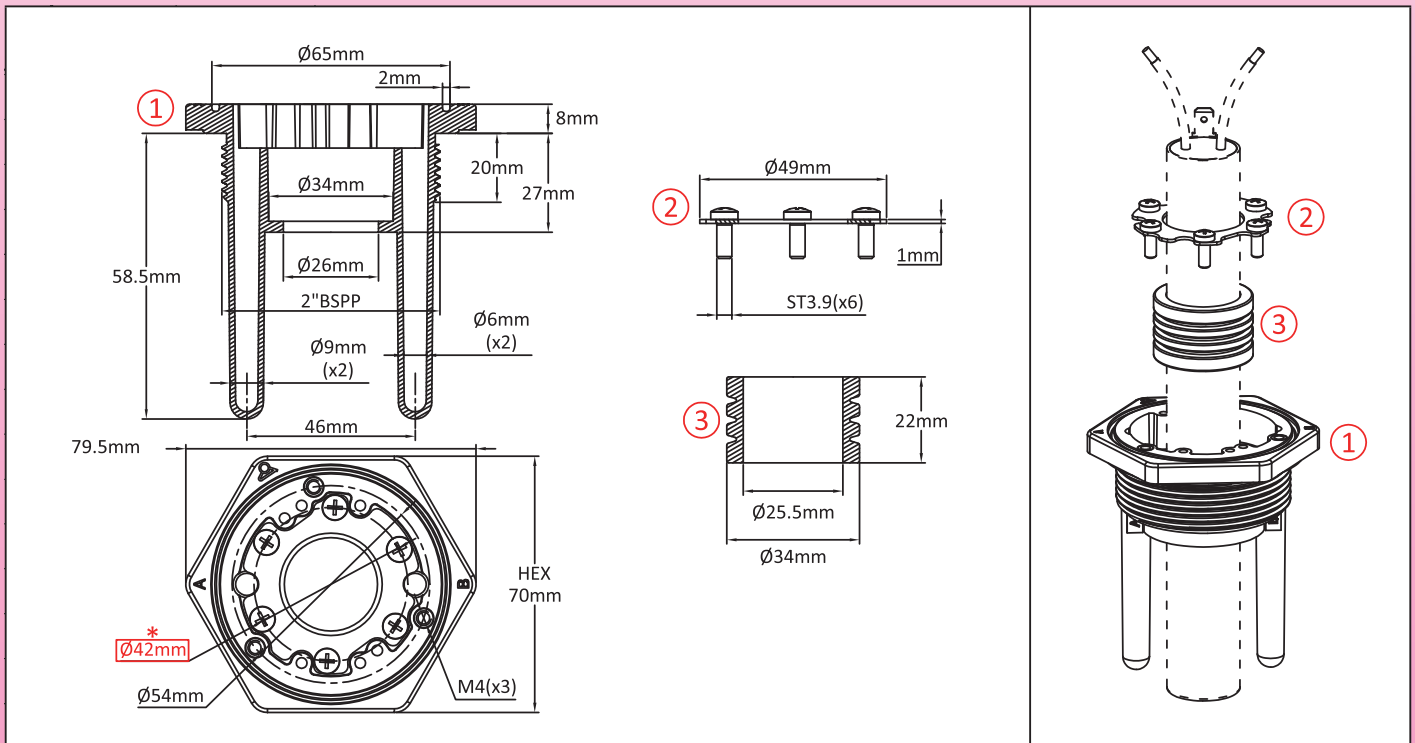

Compatible accessories		
<input checked="" type="checkbox"/> 66XF		
<input checked="" type="checkbox"/> 66JP		
<input checked="" type="checkbox"/> 66JF		
<input checked="" type="checkbox"/> 66NS		
Compatible enclosures		
<input checked="" type="checkbox"/> Y305	<input checked="" type="checkbox"/> Y3P6	<input checked="" type="checkbox"/> Y3S7
<input checked="" type="checkbox"/> Y3P3	<input checked="" type="checkbox"/> Y3S5	<input checked="" type="checkbox"/> Y3C2
<input checked="" type="checkbox"/> Y3P5	<input checked="" type="checkbox"/> Y3SA	<input checked="" type="checkbox"/> Y306



### References

①	
66RYA5T026000000	
①+②+③	
③=Silicone	66RYA5T026000006
③=FKM	66RYA5T026000008
③=NBR	66RYA5T026000007

### Links

	Page (.pdf)
	Drawing 2D (.dwg)
	Drawing 3D (.stp)

Red dimensions inside rectangular frames are used for assembly on enclosures or on fittings.



## Brass fittings, double thread, without grounding terminal

Minimum Size	Maximum Size	Material	Type	Model
<b>1"</b>	<b>M77x2</b>	<b>Brass</b>	<b>Double thread, no ground</b>	<b>66RB</b>

Compatible accessories		
<input checked="" type="checkbox"/> 66JP	<input checked="" type="checkbox"/> 66NL	
<input checked="" type="checkbox"/> 66JF	<input checked="" type="checkbox"/> 66XN	
Compatible enclosures		
<input checked="" type="checkbox"/> Y303	<input checked="" type="checkbox"/> Y3P5	<input checked="" type="checkbox"/> Y3N2
<input checked="" type="checkbox"/> Y304	<input checked="" type="checkbox"/> Y3P6	<input checked="" type="checkbox"/> Y3N3
<input checked="" type="checkbox"/> Y305	<input checked="" type="checkbox"/> Y3H1	<input checked="" type="checkbox"/> Y3N4
<input checked="" type="checkbox"/> Y306	<input checked="" type="checkbox"/> Y3H2	<input checked="" type="checkbox"/> Y3L1
<input checked="" type="checkbox"/> Y307	<input checked="" type="checkbox"/> Y3H3	<input checked="" type="checkbox"/> Y3L3
<input checked="" type="checkbox"/> Y309	<input checked="" type="checkbox"/> Y3J1	<input checked="" type="checkbox"/> Y3S3
<input checked="" type="checkbox"/> Y310	<input checked="" type="checkbox"/> Y3J2	<input checked="" type="checkbox"/> Y3S5
<input checked="" type="checkbox"/> Y3P1	<input checked="" type="checkbox"/> Y3G1	<input checked="" type="checkbox"/> Y3SA
<input checked="" type="checkbox"/> Y3P3	<input checked="" type="checkbox"/> Y3G2	<input checked="" type="checkbox"/> Y3S7
<input checked="" type="checkbox"/> Y3P4	<input checked="" type="checkbox"/> Y3N1	



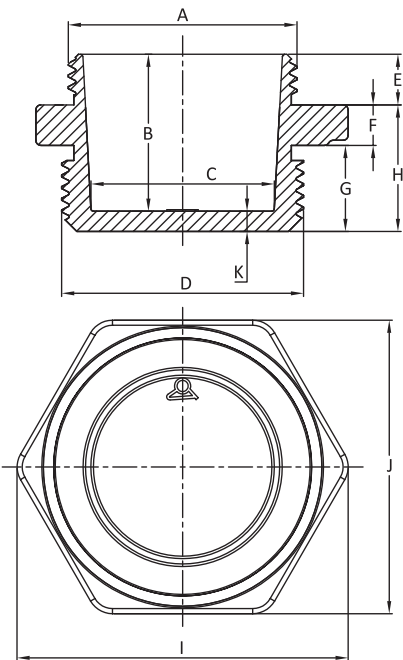

	1"	1-1/4"	1-1/2"	M45x2	2"	2-1/2"	M77x2
A	1"	1-1/4"	1-1/2"	M45x2	2"	2-1/2"	M77x2
B	31	31	31	31	34	34	34
C	Ø27	Ø35	Ø36	Ø36	Ø50	Ø66	Ø66
D	1"	1-1/4"	1-1/2"	M45x2	2"	2-1/2"	M77x2
E	10	10	10	10	10	10	10
F	8	8	8	8	8	8	8
G	17	17	17	17	20	20	20
H	25	25	25	25	28	28	28
I	50.5	65.5	65.5	65.5	79.5	102.5	102.5
J	Hex 45	Hex 58	Hex 58	Hex 58	Hex 70	Hex 90	Hex 90
K	4	4	4	4	4	4	4



### Main references

Dimension	References	Dimension	References
1"	66RBA1T000000000	2"	66RBA5T000000000
1-1/4"	66RBA2T000000000	2-1/2"	66RBA7T000000000
1-1/2"	66RBA3T000000000	M77x2	66RBMGT000000000
M45x2	66RBMDT000000000		

### Links

	Page (.pdf)
	Drawing 2D (.dwg)
	Drawing 3D (.stp)

Red dimensions inside rectangular frames are used for assembly on enclosures or on fittings.

## Brass fittings, double thread, with side grounding terminal

Minimum Size	Maximum Size	Material	Type	Model
<b>1 1/2"</b>	<b>M77x2</b>	<b>Brass</b>	<b>Double thread, side ground</b>	<b>66RC</b>

Compatible accessories		
<input checked="" type="checkbox"/> 66JP	<input checked="" type="checkbox"/> 66NL	
<input checked="" type="checkbox"/> 66JF	<input checked="" type="checkbox"/> 66XN	
Compatible enclosures		
<input checked="" type="checkbox"/> Y303	<input checked="" type="checkbox"/> Y3P5	<input checked="" type="checkbox"/> Y3N2
<input checked="" type="checkbox"/> Y304	<input checked="" type="checkbox"/> Y3P6	<input checked="" type="checkbox"/> Y3N3
<input checked="" type="checkbox"/> Y305	<input checked="" type="checkbox"/> Y3H1	<input checked="" type="checkbox"/> Y3N4
<input checked="" type="checkbox"/> Y306	<input checked="" type="checkbox"/> Y3H2	<input checked="" type="checkbox"/> Y3L1
<input checked="" type="checkbox"/> Y307	<input checked="" type="checkbox"/> Y3H3	<input checked="" type="checkbox"/> Y3L3
<input checked="" type="checkbox"/> Y309	<input checked="" type="checkbox"/> Y3J1	<input checked="" type="checkbox"/> Y3S3
<input checked="" type="checkbox"/> Y310	<input checked="" type="checkbox"/> Y3J2	<input checked="" type="checkbox"/> Y3S5
<input checked="" type="checkbox"/> Y3P1	<input checked="" type="checkbox"/> Y3G1	<input checked="" type="checkbox"/> Y3SA
<input checked="" type="checkbox"/> Y3P3	<input checked="" type="checkbox"/> Y3G2	<input checked="" type="checkbox"/> Y3S7
<input checked="" type="checkbox"/> Y3P4	<input checked="" type="checkbox"/> Y3N1	

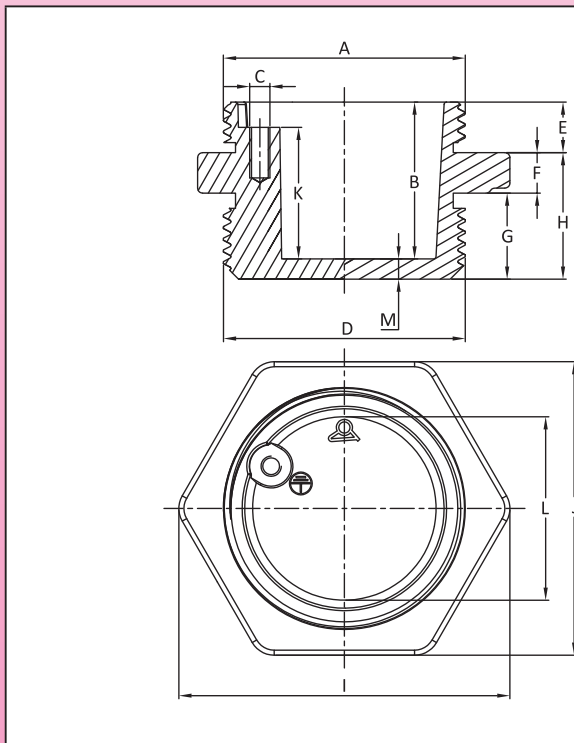

	1-1/2"	M45x2	2"	2-1/2"	M77x2
A	1-1/2"	M45x2	2"	2-1/2"	M77x2
B	31	31	34	34	34
C	M4	M4	M5	M5	M5
D	1-1/2"	M45x2	2"	2-1/2"	M77x2
E	10	10	10	10	10
F	8	8	8	8	8
G	17	17	20	20	20
H	25	25	28	28	28
I	65.5	65.5	79.5	102.5	102.5
J	Hex 58	Hex 58	Hex 70	Hex 90	Hex 90
K	26	26	28	28	28
L	Ø36	Ø36	Ø50	Ø66	Ø66
M	4	4	4	4	4

### Main references

Dimension	References	Dimension	References
1-1/2"	66RCA3T000000000	2-1/2"	66RCA70000000000
M45x2	66RCMD00000000000	M77x2	66RCMG00000000000
2"	66RCA50000000000		

### Links

Page  
(.pdf)

Drawing 2D  
(.dwg)

Drawing 3D  
(.stp)

Red dimensions inside rectangular frames are used for assembly on enclosures or on fittings.

# Brass fittings, double thread, with center grounding terminal

Minimum Size	Maximum Size	Material	Type	Model
1"	1 1/4"	Brass	Double thread, central ground	<b>66RD</b>

Compatible accessories	
<input checked="" type="checkbox"/> 66JP	<input checked="" type="checkbox"/> 66NL
<input checked="" type="checkbox"/> 66JF	<input checked="" type="checkbox"/> 66XN
Compatible enclosures	
<input checked="" type="checkbox"/> Y3L1	
<input checked="" type="checkbox"/> Y3L3	
<input checked="" type="checkbox"/> Y3S3	
<input checked="" type="checkbox"/> Y303	
<input checked="" type="checkbox"/> Y304	

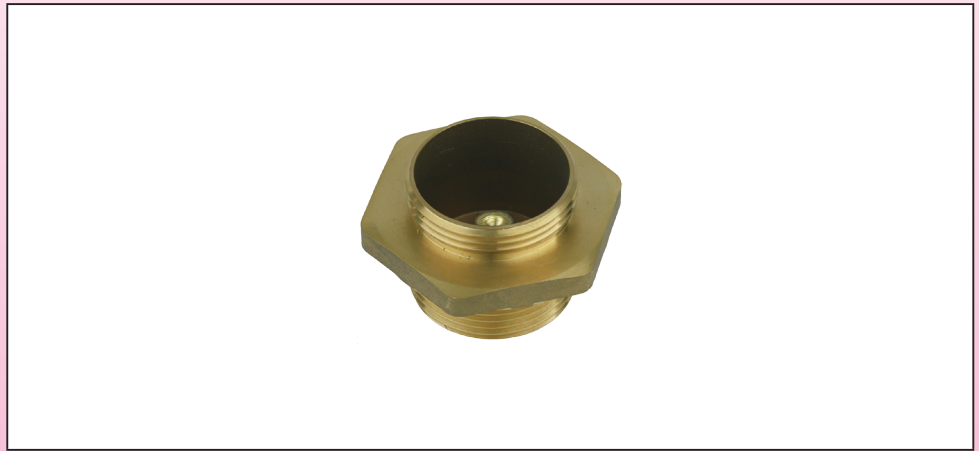

	1"	1-1/4"
A	1"	1-1/4"
B	31	31
C	M4	M4
D	1"	1-1/4"
E	10	10
F	8	8
G	17	17
H	25	25
I	50.5	65.5
J	Hex 45	Hex 58
K	8	8
L	Ø27	Ø35
M	4	4

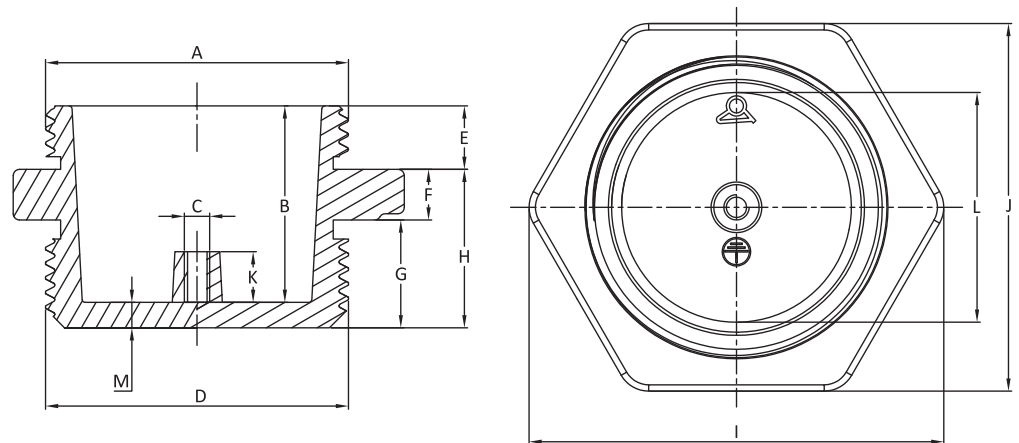

## Main references

Dimension	References	Dimension	References
1"	66RDA1T000000000	1-1/4"	66RDA2T000000000

## Links



Page  
(.pdf)



Drawing 2D  
(.dwg)



Drawing 3D  
(.stp)

Red dimensions inside rectangular frames are used for assembly on enclosures or on fittings.

# Brass fittings, single thread, with center grounding terminal

Minimum Size	Maximum Size	Material	Type	Model
1"	1"	Brass	Single thread, central ground	<b>66RF</b>

Compatible accessories
<input checked="" type="checkbox"/> 66JP <input checked="" type="checkbox"/> 66NL <input checked="" type="checkbox"/> 66JF <input checked="" type="checkbox"/> 66XF
Compatible enclosures
<input checked="" type="checkbox"/> Y301

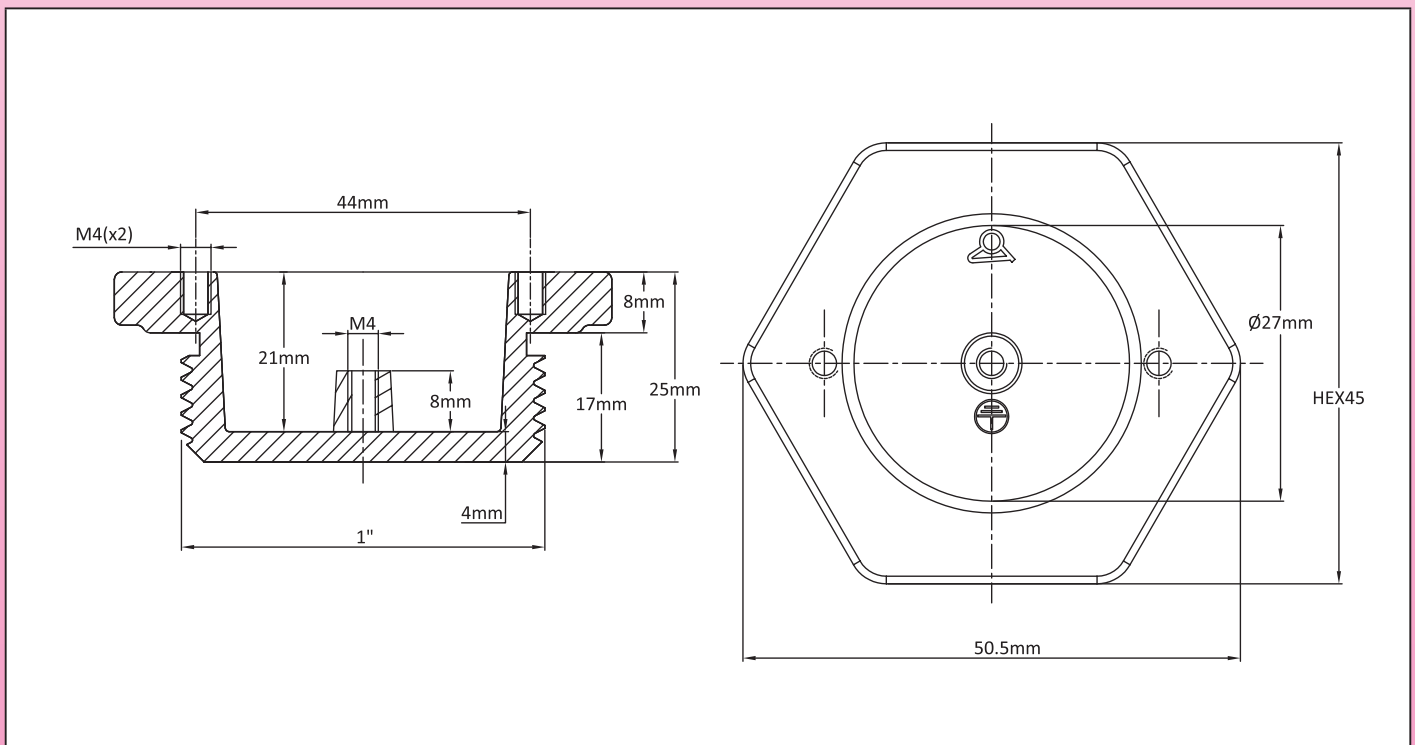

## Main reference

Dimension	Reference
1"	66RFA1T000000000

## Links



Page  
(.pdf)



Drawing 2D  
(.dwg)



Drawing 3D  
(.stp)

Red dimensions inside rectangular frames are used for assembly on enclosures or on fittings.

# Brass fitting, using 3 screws rotation ring, for common immersion heaters

Minimum Size	Maximum Size	Material	Type	Model
1 1/4"	M77x2	Brass	3 screws rotation ring	<b>66RE</b>

Compatible accessories	
<input checked="" type="checkbox"/> 66XF	<input checked="" type="checkbox"/> 66JP
<input checked="" type="checkbox"/> 66JE	<input checked="" type="checkbox"/> 66JF
<input checked="" type="checkbox"/> 66NL	<input checked="" type="checkbox"/> 66JR

Compatible enclosures			
<input checked="" type="checkbox"/> Y303	<input checked="" type="checkbox"/> Y3H1	<input checked="" type="checkbox"/> Y310	<input checked="" type="checkbox"/> Y302
<input checked="" type="checkbox"/> Y304	<input checked="" type="checkbox"/> Y3H2	<input checked="" type="checkbox"/> Y3L3	<input checked="" type="checkbox"/> Y3C1
<input checked="" type="checkbox"/> Y305	<input checked="" type="checkbox"/> Y3H3	<input checked="" type="checkbox"/> Y3S3	<input checked="" type="checkbox"/> Y3C3
<input checked="" type="checkbox"/> Y3P1	<input checked="" type="checkbox"/> Y3G1	<input checked="" type="checkbox"/> Y3S5	<input checked="" type="checkbox"/> Y307
<input checked="" type="checkbox"/> Y3P3	<input checked="" type="checkbox"/> Y3G2	<input checked="" type="checkbox"/> Y3N1	<input checked="" type="checkbox"/> Y3K1
<input checked="" type="checkbox"/> Y3P4	<input checked="" type="checkbox"/> Y309	<input checked="" type="checkbox"/> Y3N2	<input checked="" type="checkbox"/> Y3K2
<input checked="" type="checkbox"/> Y3P5	<input checked="" type="checkbox"/> Y3J1	<input checked="" type="checkbox"/> Y3N3	<input checked="" type="checkbox"/> Y3SA
<input checked="" type="checkbox"/> Y3P6	<input checked="" type="checkbox"/> Y3J2	<input checked="" type="checkbox"/> Y3N4	<input checked="" type="checkbox"/> Y3S7
<input checked="" type="checkbox"/> Y3B2	<input checked="" type="checkbox"/> Y306	<input checked="" type="checkbox"/> Y3C4	<input checked="" type="checkbox"/> Y3M1

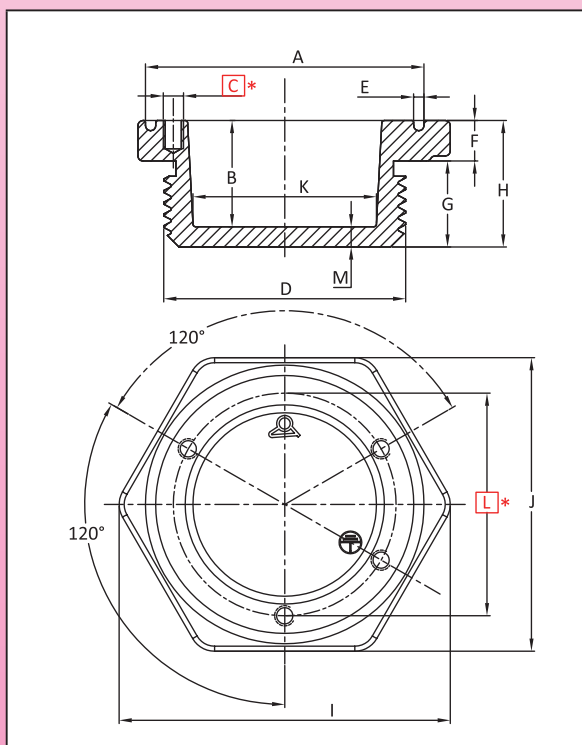

	1-1/4"	1-1/2"	M45x2	2"	2-1/2"	M77x2
A	Ø55	Ø55	Ø55	Ø65	Ø82	Ø82
B	21	21	21	24	24	24
C	M4(x4)	M4(x4)	M4(x4)	M4(x4)	M5(x4)	M5(x4)
D	1-1/4"	1-1/2"	M45x2	2"	2-1/2"	M77x2
E	2	2	2	2	2	2
F	8	8	8	8	8	8
G	17	17	17	20	20	20
H	25	25	25	28	28	28
I	65.5	65.5	65.5	79.5	102.5	102.5
J	Hex 58	Hex 58	Hex 58	Hex 70	Hex 90	Hex 90
K	Ø35	Ø36	Ø36	Ø50	Ø66	Ø66
L	Ø44	Ø44	Ø44	Ø54	Ø70	Ø70
M	4	4	4	4	4	4

### Main references

Dimension	References	Dimension	References
1-1/4"	66REA2T000000000	2"	66REA5T000000000
1-1/2"	66REA3T000000000	2-1/2"	66REA7T000000000
M45x2	66REMDT000000000	M77x2	66REMG000000000

### Links



Page  
(.pdf)

---



Drawing 2D  
(.dwg)

---



Drawing 3D  
(.stp)

Red dimensions inside rectangular frames are used for assembly on enclosures or on fittings.

Because of permanent improvement of our products, drawings, descriptions, features used on these data sheets are for guidance only and can be modified without prior advice

## Lightened brass fittings, single thread

Minimum Size	Maximum Size	Material	Type	Model
<b>1 1/4"</b>	<b>M45x2</b>	<b>Brass</b>	<b>Single thread</b>	<b>66RG</b>

Compatible accessories
<input checked="" type="checkbox"/> 66JP
<input checked="" type="checkbox"/> 66JF
<input checked="" type="checkbox"/> 66NL
Compatible enclosures
<input checked="" type="checkbox"/> Y3L4
<input checked="" type="checkbox"/> Y3S4



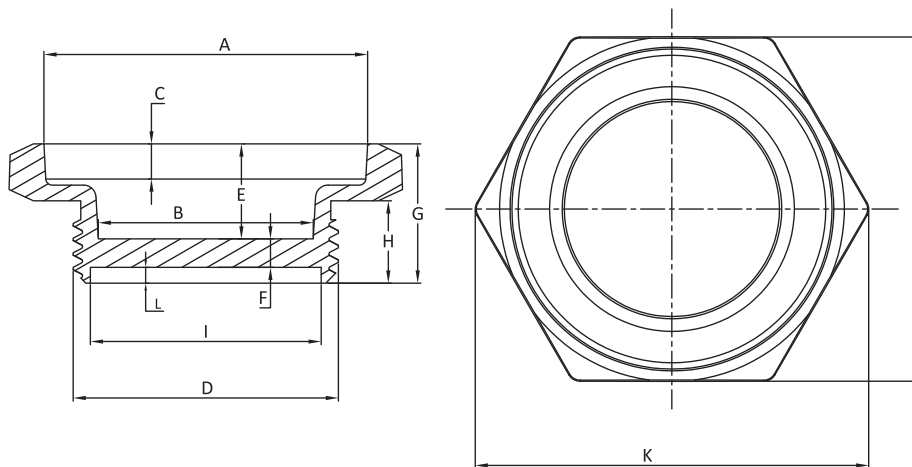

	1-1/4"	1-1/2"	M45x2
A	Ø50.5	Ø55	Ø55
B	Ø34	Ø40	Ø40
C	5.5	5.5	5.5
D	1-1/4"	1-1/2"	M45x2
E	15	15	15
F	4.5	4.5	4.5
G	22	22	22
H	13	13	13
I	Ø36.5	Ø36.5	Ø36.5
J	Hex 54	Hex 58	Hex 58
K	61	65.5	65.5
L	2.5	2.5	2.5



### Main references

Dimension	References	Dimension	References
1-1/4"	66RGA2T000000000	M45x2	66RGMdT000000000
1-1/2"	66RGA3T000000000		

### Links

	Page (.pdf)
	Drawing 2D (.dwg)
	Drawing 3D (.stp)

Red dimensions inside rectangular frames are used for assembly on enclosures or on fittings.



# Enclosure accessories

The references given in these documents are the most common. The dotted areas in the plans indicate the options.

Red dimensions inside rectangular frames on drawings are used for assembly on enclosures or on fittings.

For more information consult our technical service.





# Fitting gaskets for immersion heaters, thermostats, temperature sensors or level sensors in silicone, NBR, PTFE

Minimum Size	Maximum Size	Material	Type	Model
<b>1"</b>	<b>M77 × 2</b>	<b>Silicone NBR PTFE</b>	<b>Elastomeric flat gaskets</b>	<b>66JP</b>

### Compatible with:

☒ 66RJ	☒ 66R3
☒ 66RU	☒ 66R4
☒ 66RK	☒ 66R5
☒ 66RV	☒ 66R6
☒ 66RO	☒ 66R7
☒ 66RP	☒ 66R8
☒ 66RQ	☒ 66R9
☒ 66RR	☒ 66RW
☒ 66R2	☒ 66RY

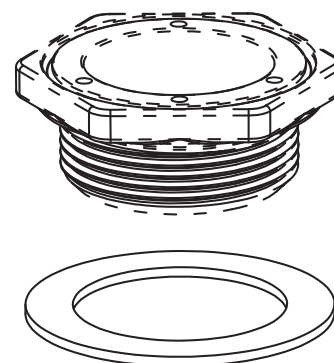
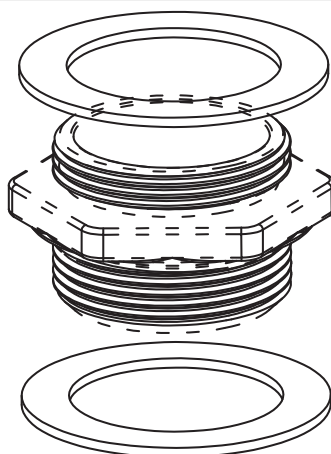
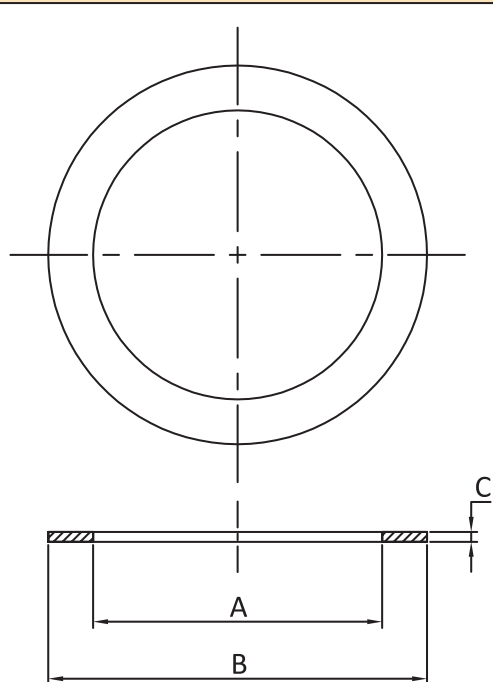
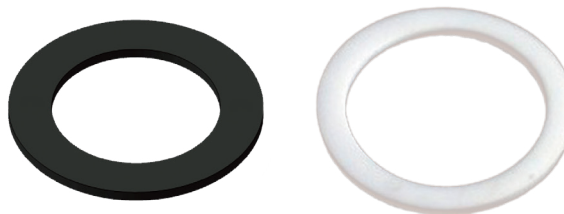

	1"	1-1/4"	1-1/2"	M45x2	2"	2-1/2"	M77x2
A	Ø32	Ø40	Ø44	Ø44	Ø58	Ø74	Ø74
B	Ø50	Ø62	Ø62	Ø62	Ø76	Ø95	Ø95
C	2	2	2	2	2	2	2

### Main references

Dimensions	References in Silicone	References in NBR	References in PTFE
1"	66JPS32020500000	66JPN32020500000	66JPP32020500000
1-1/4"	66JPS40020620000	66JPN40020620000	66JPP40020620000
1-1/2" M45×2	66JPS44020620000	66JPN44020620000	66JPP44020620000
2"	66JPS58020760000	66JPN58020760000	66JPP58020760000
2-1/2" M77×2	66JPS74020950000	66JPN74020950000	66JPP74020950000

### Links



Page  
(.pdf)



Drawing 2D  
(.dwg)



Drawing 3D  
(.stp)

Red dimensions inside rectangular frames on drawings are used for assembly on enclosures or on fittings.

# Fitting gaskets for immersion heaters, thermostats, temperature sensors or level sensors in compressed fiber without asbestos

Minimum Size	Maximum Size	Material	Type	Model
<b>1"</b>	<b>M77 × 2</b>	<b>Asbestos-free compressed fiber</b>	<b>Rigid flat gaskets</b>	<b>66JF</b>

Compatible with:	
☒ 66RJ	☒ 66R3
☒ 66RU	☒ 66R4
☒ 66RK	☒ 66R5
☒ 66RV	☒ 66R6
☒ 66RO	☒ 66R7
☒ 66RP	☒ 66R8
☒ 66RQ	☒ 66R9
☒ 66RR	☒ 66RW
☒ 66R2	☒ 66RY

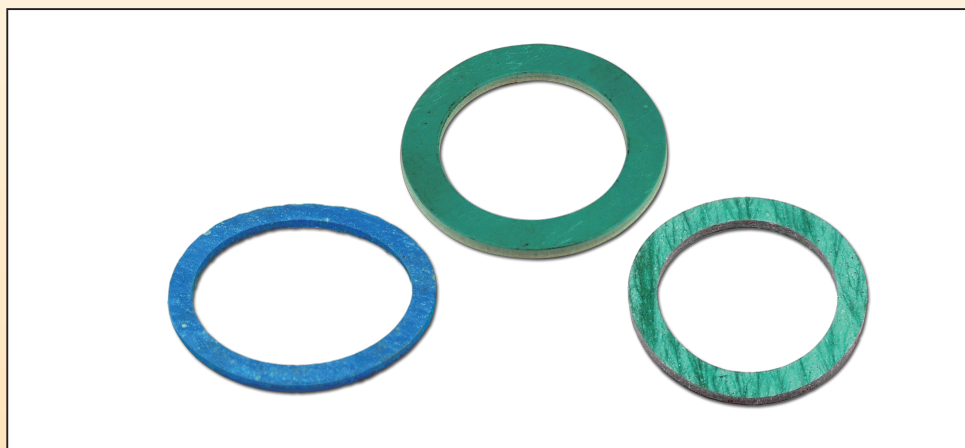

	1"	1-1/4"	1-1/2"	M45x2	2"	2-1/2"	M77x2
A	Ø32	Ø40	Ø44	Ø44	Ø58	Ø74	Ø74
B	Ø50	Ø62	Ø62	Ø62	Ø76	Ø95	Ø95
C	2.2	2.2	2.2	2.2	2.2	2.2	2.2

### Main references

Dimensions	References	Dimensions	References
1"	66JFC32022500000	2"	66JFC58022760000
1-1/4"	66JFC40022620000	2-1/2" M77x2	66JFC74022950000
1-1/2" M45x2	66JFC44022620000		

### Links

Page  
(.pdf)

Drawing 2D  
(.dwg)

Drawing 3D  
(.stp)

Red dimensions inside rectangular frames on drawings are used for assembly on enclosures or on fittings.

# Gaskets with centering lip, for fittings with rotation ring, in silicone or NBR

Minimum Size	Maximum Size	Material	Type	Model
1"	M77 × 2	Silicone NBR FKM (Viton)	Elastomeric gasket with centering lip	<b>66JL</b>

Compatible with:	
☒ 66RJ	☒ 66R3
☒ 66RU	☒ 66R4
☒ 66RK	☒ 66R5
☒ 66RV	☒ 66R6
☒ 66RO	☒ 66R7
☒ 66RP	☒ 66R8
☒ 66RQ	☒ 66R9
☒ 66RR	☒ 66RW
☒ 66R2	☒ 66RY



	1"	1-1/4"	1-1/2"	M45x2	2"	2-1/2"	M77x2
A	Ø32	Ø58	Ø58	Ø58	Ø70	Ø90	Ø90
B	Ø50	Ø50	Ø50	Ø50	Ø60	Ø77	Ø77
C	2	2	2	2	2	2	2
D	/	Ø55	Ø55	Ø55	Ø65	Ø81	Ø81
E	/	2	2	2	2	2	2
F	/	4	4	4	4	4	4

### Main references

Dimensions	References in Silicone	References in NBR	References in FKM(Viton)
1"	66JLS32040500000	66JLN32040500000	66JLV32040500000
1-1/4" 1-1/2" M45x2	66JLS58040500000	66JLN58040500000	66JLV58040500000
2"	66JLS70040600000	66JLN70040600000	66JLV70040600000
2-1/2" M77x2	66JLS90040770000	66JLN90040770000	66JLV90040770000

### Links

Page  
(.pdf)

Drawing 2D  
(.dwg)

Drawing 3D  
(.stp)

Because of permanent improvement of our products, drawings, descriptions, features used on these data sheets are for guidance only and can be modified without prior advice

Red dimensions inside rectangular frames on drawings are used for assembly on enclosures or on fittings.

# O-ring type gaskets for immersion heaters, thermostats, temperature sensors or level sensors fittings, in NBR or silicone

Minimum Size	Maximum Size	Material	Type	Model
1¼"	M77 × 2	Silicone NBR	O-ring for rotation ring	<b>66JR</b> (P1)

Compatible with:	
<input checked="" type="checkbox"/> 66RE <input checked="" type="checkbox"/> 66RW <input checked="" type="checkbox"/> 66RY	

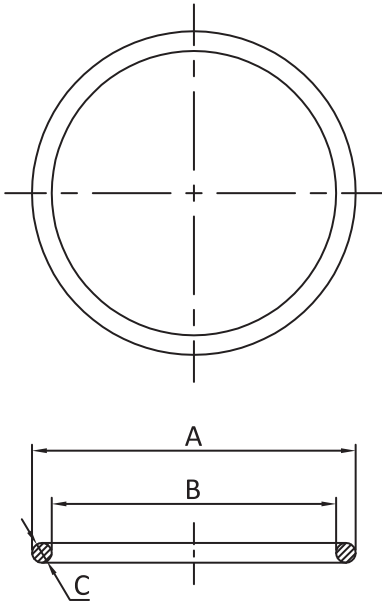

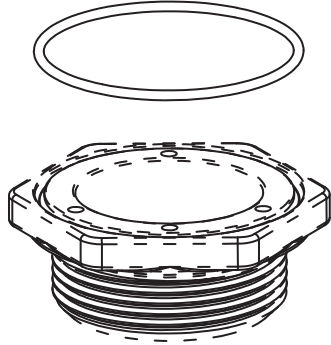



	1-1/4"	1-1/2"	M45x2	2"	2-1/2"	M77x2
A	Ø55	Ø55	Ø55	Ø65	Ø82	Ø82
B	Ø51	Ø51	Ø51	Ø61	Ø78	Ø78
C	Ø2	Ø2	Ø2	Ø2	Ø2	Ø2

### Main references

Dimensions	References in Silicone	References in NBR
1-1/4" 1-1/2" M45x2	66JRS55020510000	66JRN55020510000
2"	66JRS65020610000	66JRN65020610000
2-1/2" M77x2	66JRS82020780000	66JRN82020780000

### Links

	Page (.pdf)
	Drawing 2D (.dwg)
	Drawing 3D (.stp)

Red dimensions inside rectangular frames on drawings are used for assembly on enclosures or on fittings.

# O-ring type gaskets for large stamped immersion heaters fittings, in NBR or silicone

Minimum Size	Maximum Size	Material	Type	Model
1¼"	M45 × 2	Silicone NBR	O-ring for large fitting	<b>66JR</b> (P2)

Compatible with:	
<input checked="" type="checkbox"/> 66R2	<input checked="" type="checkbox"/> 66R6
<input checked="" type="checkbox"/> 66R3	<input checked="" type="checkbox"/> 66R7
<input checked="" type="checkbox"/> 66R4	<input checked="" type="checkbox"/> 66R8
<input checked="" type="checkbox"/> 66R5	<input checked="" type="checkbox"/> 66R9



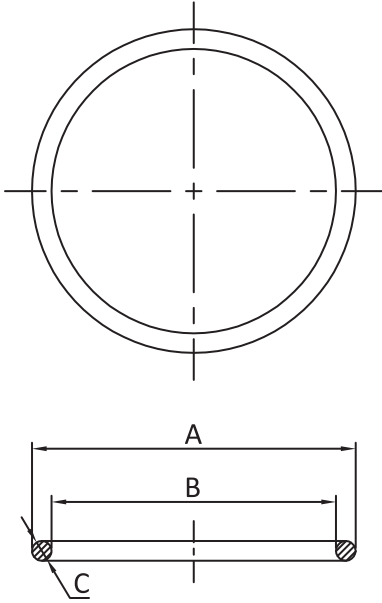

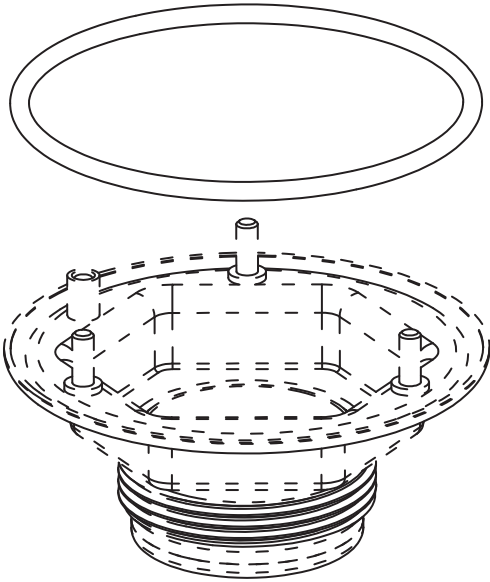

	1-1/4"	1-1/2"	M45x2
A	Ø87	Ø87	Ø87
B	Ø81	Ø81	Ø81
C	Ø3	Ø3	Ø3

### Main references

Dimensions	References in NBR	References in silicone
1-1/4"	66JRN87030810000	66JRS87030810000
1-1/2"		
M45×2		

### Links



Page  
(.pdf)



Drawing 2D  
(.dwg)



Drawing 3D  
(.stp)

Red dimensions inside rectangular frames on drawings are used for assembly on enclosures or on fittings.

# Hexagonal capping gasket for deep drawn stainless steel fittings

Minimum Size	Maximum Size	Material	Type	Model
1¼"	M77 × 2	Silicone NBR	Wrapping gaskets	<b>66JE</b>

### Compatible with:

- |  |  |
|--|--|
| <input checked="" type="checkbox"/> 66RJ | <input checked="" type="checkbox"/> 66RO |
| <input checked="" type="checkbox"/> 66RU | <input checked="" type="checkbox"/> 66RP |
| <input checked="" type="checkbox"/> 66RK | <input checked="" type="checkbox"/> 66RQ |
| <input checked="" type="checkbox"/> 66RV | <input checked="" type="checkbox"/> 66RR |

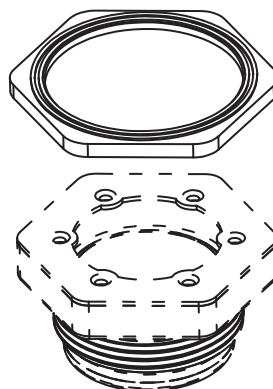
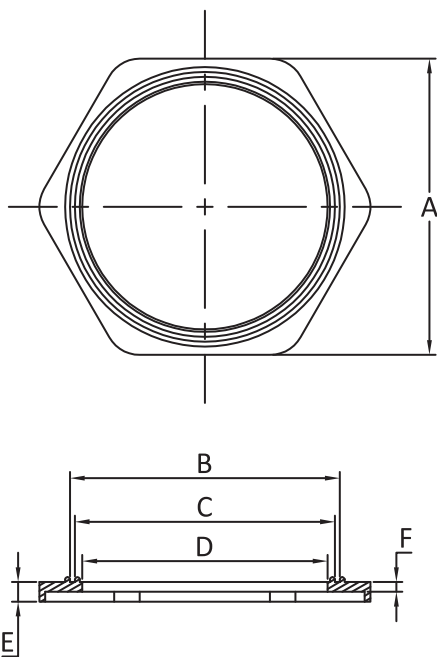

	1-1/4"	1-1/2"	M45x2	2-1/2"	M77x2
A	Hex 60	Hex 60	Hex 60	Hex 92	Hex 92
B	Ø55	Ø55	Ø55	Ø87	Ø87
C	Ø53	Ø53	Ø53	Ø84	Ø84
D	Ø50	Ø50	Ø50	Ø80	Ø80
E	4	4	4	4	4
F	2	2	2	2	2

### Main references

Dimensions	References in NBR	References in silicone
1-1/4" 1-1/2" M45×2	66JEN50040H60000	66JES50040H60000
2-1/2" M77×2	66JEN80040H92000	66JES80040H92000

### Links



Page  
(.pdf)



Drawing 2D  
(.dwg)



Drawing 3D  
(.stp)

Red dimensions inside rectangular frames on drawings are used for assembly on enclosures or on fittings.

## Lock nuts for fittings, in 304, 316 stainless steel, and brass

Minimum Size	Maximum Size	Material	Type	Model
1/2"	M77 x 2	304, 316 stainless steel, and brass	Nuts	66NL (Brass) 66NI (304) 66NT (316) 66NK (Brass, Nickel plated)

### Compatible with:

☒ 66RJ	☒ 66R3
☒ 66RU	☒ 66R4
☒ 66RK	☒ 66R5
☒ 66RV	☒ 66R6
☒ 66RO	☒ 66R7
☒ 66RP	☒ 66R8
☒ 66RQ	☒ 66R9
☒ 66RR	☒ 66RW
☒ 66R2	☒ 66RY

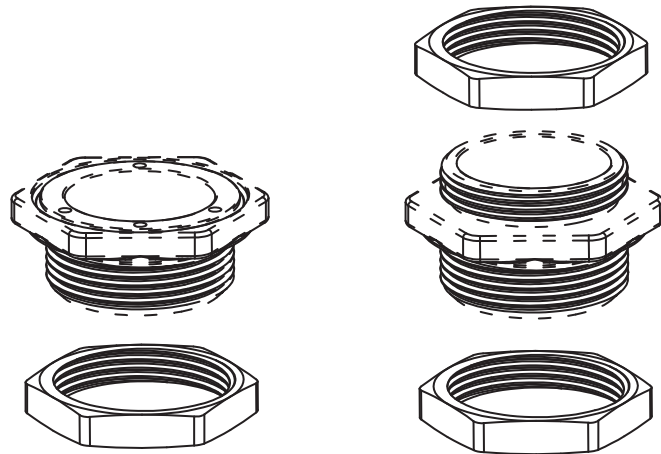
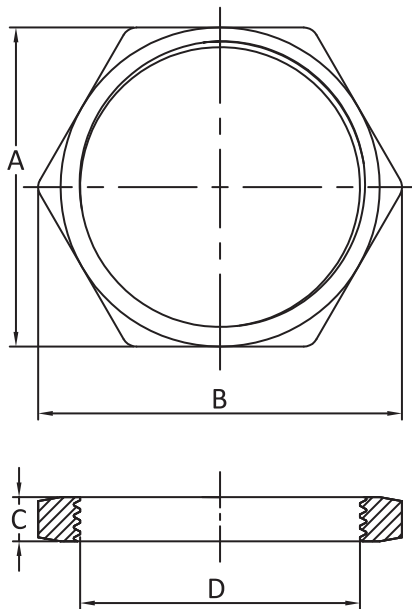
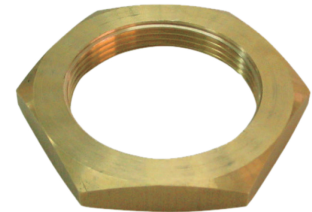

	1/2"	3/4"	1"	1-1/4"	1-1/2"	M45x2	2"	2-1/2"	M77x2
A	Hex 44	Hex 44	Hex 44	Hex 50	Hex 52	Hex 52	Hex 65	Hex 85	Hex 85
B	24	30	50	57	59	59	74	97	97
C	3	3	5.5	6.5	8	8	8	8	8
D	1/2"	3/4"	1"	1-1/4"	1-1/2"	M45x2	2"	2-1/2"	M77x2

### Main references

Dimensions	Reference in Brass	Reference in nickel plated brass	Reference in AISI 304	Reference in AISI 304
1/2"	66NLC01230H44000	66NKC01230H44000	66NIC01230H44000	66NTC01230H44000
3/4"	66NLC03430H44000	66NKC03430H44000	66NIC03430H44000	66NTC03430H44000
1"	66NLC10055H44000	66NKC10055H44000	66NIC10055H44000	66NTC10055H44000
1-1/4"	66NLC11465H50000	66NKC11465H50000	66NIC11465H50000	66NTC11465H50000
1-1/2"	66NLC11280H52000	66NKC11280H52000	66NIC11280H52000	66NTC11280H52000
M45x2	66NLM45280H52000	66NKM45280H52000	66NIM45280H52000	66NTM45280H52000
2"	66NLC20080H65000	66NKC20080H65000	66NIC20080H65000	66NTC20080H65000
2-1/2"	66NLC21280H85000	66NKC21280H85000	66NIC21280H85000	66NTC21280H85000
M77x2	66NLM77280H85000	66NKM77280H85000	66NIM77280H85000	66NTM77280H85000

### Links



Page  
(.pdf)



Drawing 2D  
(.dwg)





Drawing 3D  
(.stp)

Red dimensions inside rectangular frames on drawings are used for assembly on enclosures or on fittings.

# Internal saddles for round enclosures assembly on fittings

Minimum Size	Maximum Size	Material	Type	Model
<b>1½"</b>	<b>2½"</b>	<b>304 Stainless steel</b>	<b>Internal saddles</b>	<b>66KE</b>

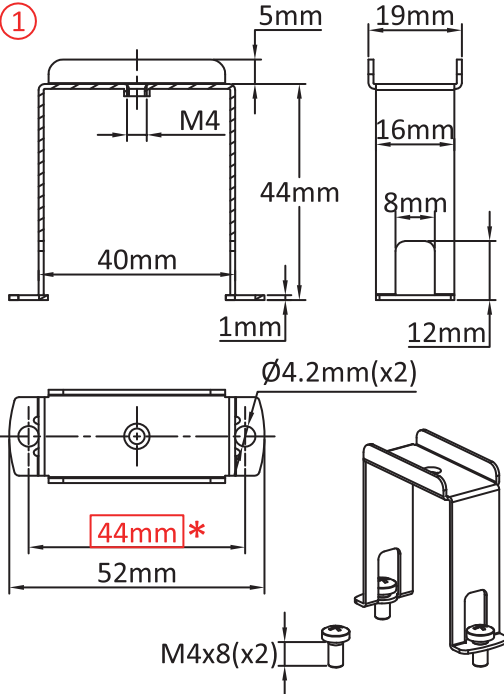
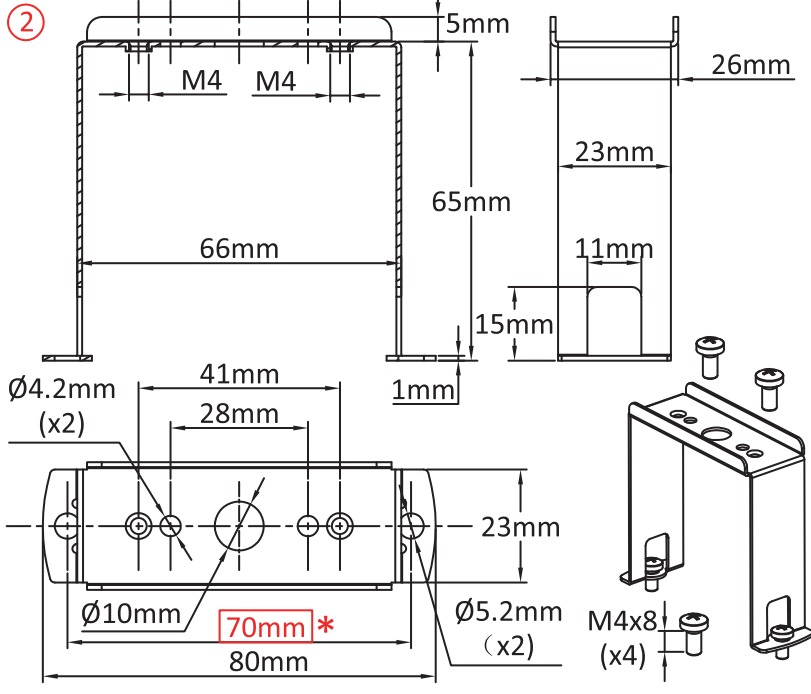

Compatible with:			
①	②	①	②
<input checked="" type="checkbox"/> Y302 <input checked="" type="checkbox"/> Y3K1 <input checked="" type="checkbox"/> Y3C1 <input checked="" type="checkbox"/> Y3C2	<input checked="" type="checkbox"/> Y3K2 <input checked="" type="checkbox"/> Y3C3		

<p style="text-align: center; color: red;">①</p> 	<p style="text-align: center; color: red;">②</p> 
---	--

**Main references**

**Links**

①	②
66KE1I0000000000	66KE2I0000000000

	Page (.pdf)
	Drawing 2D (.dwg)
	Drawing 3D (.stp)

Red dimensions inside rectangular frames on drawings are used for assembly on enclosures or on fittings.



# Rails for assembly of thermostats

Minimum Size	Maximum Size	Material	Type	Model
1 thermostat	2 thermostats	304 Stainless steel	Thermostats mounting	<b>66KP 66KG</b>

Compatible with:			①	③											
①	<table border="0"> <tr><td>☒ Y3S5</td><td>☒ Y3S6</td><td>☒ Y3S7</td></tr> <tr><td>☒ Y3S8</td><td>☒ Y3S9</td><td>☒ Y3T8</td></tr> <tr><td>☒ Y3TA</td><td>☒ Y3O5</td><td>☒ Y3O6</td></tr> <tr><td>☒ Y3C4</td><td></td><td></td></tr> </table>	☒ Y3S5	☒ Y3S6	☒ Y3S7	☒ Y3S8	☒ Y3S9	☒ Y3T8	☒ Y3TA	☒ Y3O5	☒ Y3O6	☒ Y3C4				
☒ Y3S5	☒ Y3S6	☒ Y3S7													
☒ Y3S8	☒ Y3S9	☒ Y3T8													
☒ Y3TA	☒ Y3O5	☒ Y3O6													
☒ Y3C4															
②	<table border="0"> <tr><td>☒ Y3S3</td><td>☒ Y3S4</td><td>☒ Y3O3</td></tr> <tr><td>☒ Y3O4</td><td>☒ Y3P1</td><td>☒ Y3P3</td></tr> <tr><td>☒ Y3P5</td><td>☒ Y3O7</td><td>☒ Y3M1</td></tr> </table>	☒ Y3S3	☒ Y3S4	☒ Y3O3	☒ Y3O4	☒ Y3P1	☒ Y3P3	☒ Y3P5	☒ Y3O7	☒ Y3M1					
☒ Y3S3	☒ Y3S4	☒ Y3O3													
☒ Y3O4	☒ Y3P1	☒ Y3P3													
☒ Y3P5	☒ Y3O7	☒ Y3M1													
③	<table border="0"> <tr><td>☒ Y3L3</td><td>☒ Y3S3</td><td>☒ Y3S4</td></tr> <tr><td>☒ Y3S5</td><td>☒ Y3S6</td><td>☒ Y3SA</td></tr> <tr><td>☒ Y3SB</td><td>☒ Y3SC</td><td>☒ Y3TB</td></tr> </table>	☒ Y3L3	☒ Y3S3	☒ Y3S4	☒ Y3S5	☒ Y3S6	☒ Y3SA	☒ Y3SB	☒ Y3SC	☒ Y3TB					
☒ Y3L3	☒ Y3S3	☒ Y3S4													
☒ Y3S5	☒ Y3S6	☒ Y3SA													
☒ Y3SB	☒ Y3SC	☒ Y3TB													
④	<table border="0"> <tr><td>☒ Y3SA</td><td>☒ Y3SB</td><td>☒ Y3SC</td></tr> <tr><td>☒ Y3TB</td><td>☒ Y3TC</td><td>☒ Y3P5</td></tr> </table>	☒ Y3SA	☒ Y3SB	☒ Y3SC	☒ Y3TB	☒ Y3TC	☒ Y3P5								
☒ Y3SA	☒ Y3SB	☒ Y3SC													
☒ Y3TB	☒ Y3TC	☒ Y3P5													

<p>①</p>	<p>②</p>	
<p>④</p>	<p>③</p>	

### Main references

### Links

①	②	③	④
66KU2	66KU1	66KG1	66KU3



Page  
(.pdf)



Drawing 2D  
(.dwg)



Drawing 3D  
(.stp)

Red dimensions inside rectangular frames on drawings are used for assembly on enclosures or on fittings.

# DIN rails for assembly of temperature controllers, contactors and power relays

Minimum Size	Maximum Size	Material	Type	Model
1 contacteur	2 contacteurs	304 Stainless steel	Din rail	<b>66KD</b>

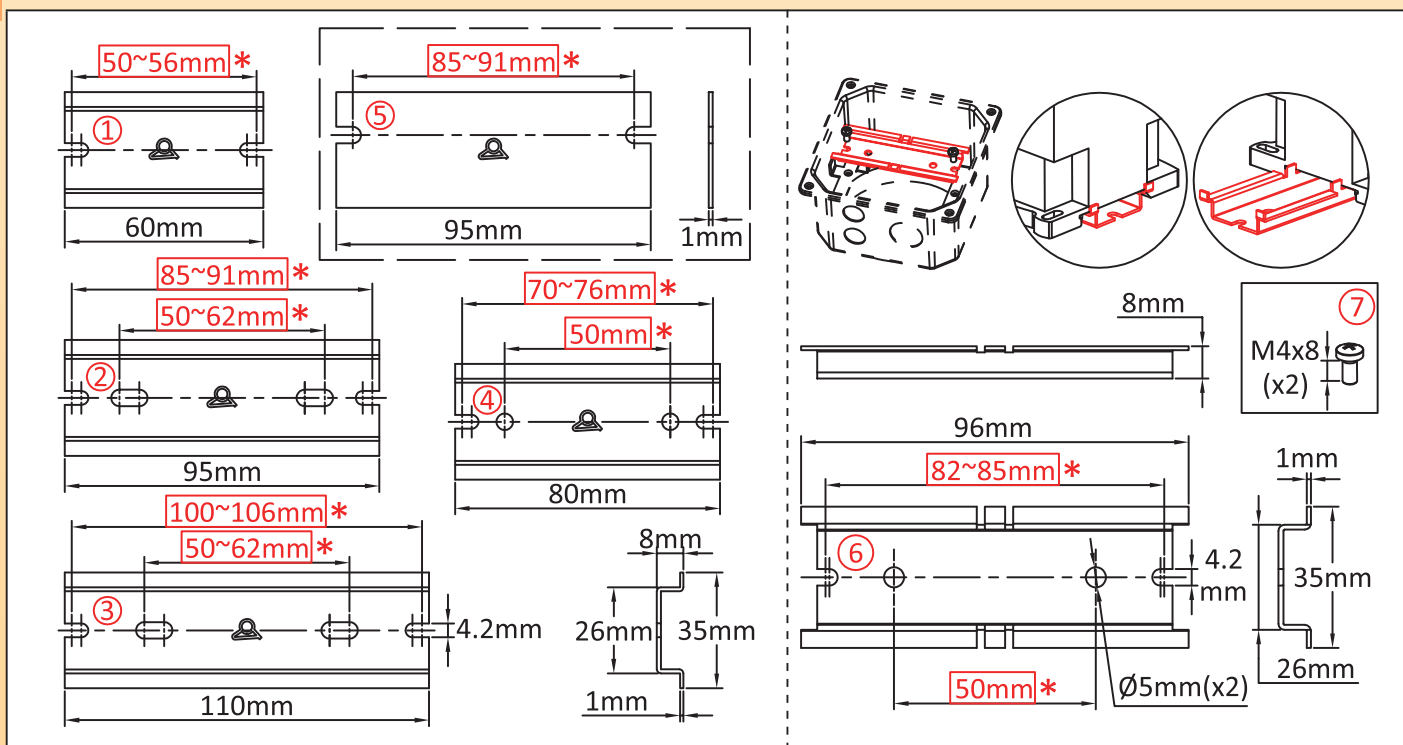
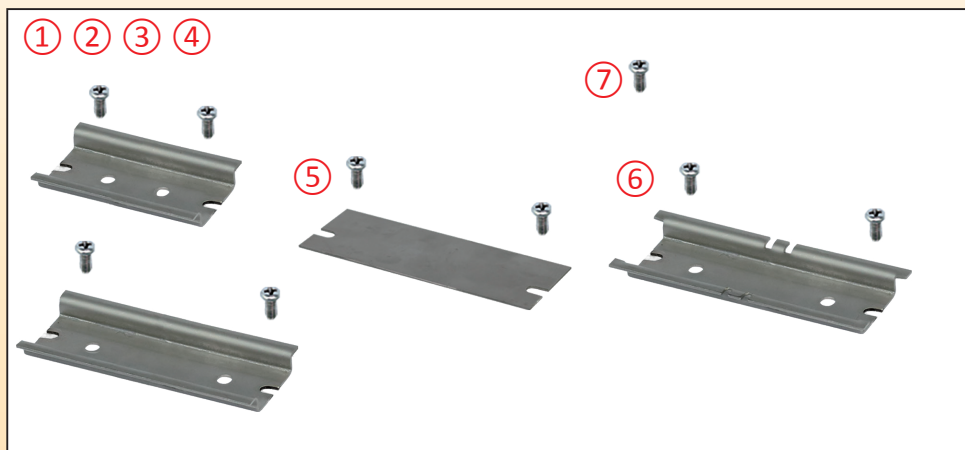

Compatible with:		
① ② ③ ④		
<input checked="" type="checkbox"/> Y303	<input checked="" type="checkbox"/> Y3S4	<input checked="" type="checkbox"/> Y3M1
<input checked="" type="checkbox"/> Y304	<input checked="" type="checkbox"/> Y3S5	<input checked="" type="checkbox"/> Y3N1
<input checked="" type="checkbox"/> Y305	<input checked="" type="checkbox"/> Y3P1	<input checked="" type="checkbox"/> Y3N2
<input checked="" type="checkbox"/> Y306	<input checked="" type="checkbox"/> Y3P3	<input checked="" type="checkbox"/> Y3N3
<input checked="" type="checkbox"/> Y307	<input checked="" type="checkbox"/> Y3P5	<input checked="" type="checkbox"/> Y3N4
<input checked="" type="checkbox"/> Y3S3	<input checked="" type="checkbox"/> Y3C4	
⑤		
<input checked="" type="checkbox"/> Y3N1	<input checked="" type="checkbox"/> Y3N2	<input checked="" type="checkbox"/> Y3N3
<input checked="" type="checkbox"/> Y3N4		
⑥		
<input checked="" type="checkbox"/> Y3TB	<input checked="" type="checkbox"/> Y3TC	<input checked="" type="checkbox"/> Y3T8
<input checked="" type="checkbox"/> Y3TA		



## Main references

①+⑦	66KD3I0000000000
②+⑦	66KD4I0000000000
③+⑦	66KD5I0000000000
④+⑦	66KD6I0000000000
⑤+⑦	66KD1I0000000000
⑥+⑦	66KD2I0000000000

## Links

	Page (.pdf)
	Drawing 2D (.dwg)
	Drawing 3D (.stp)

Red dimensions inside rectangular frames on drawings are used for assembly on enclosures or on fittings.

# Grommets used to close access to internal adjustment shafts, in silicone

Minimum Size	Maximum Size	Material	Type	Model
Dia. 23.5mm	Dia. 23.5mm	Silicone	Plug	<b>66Q1</b>

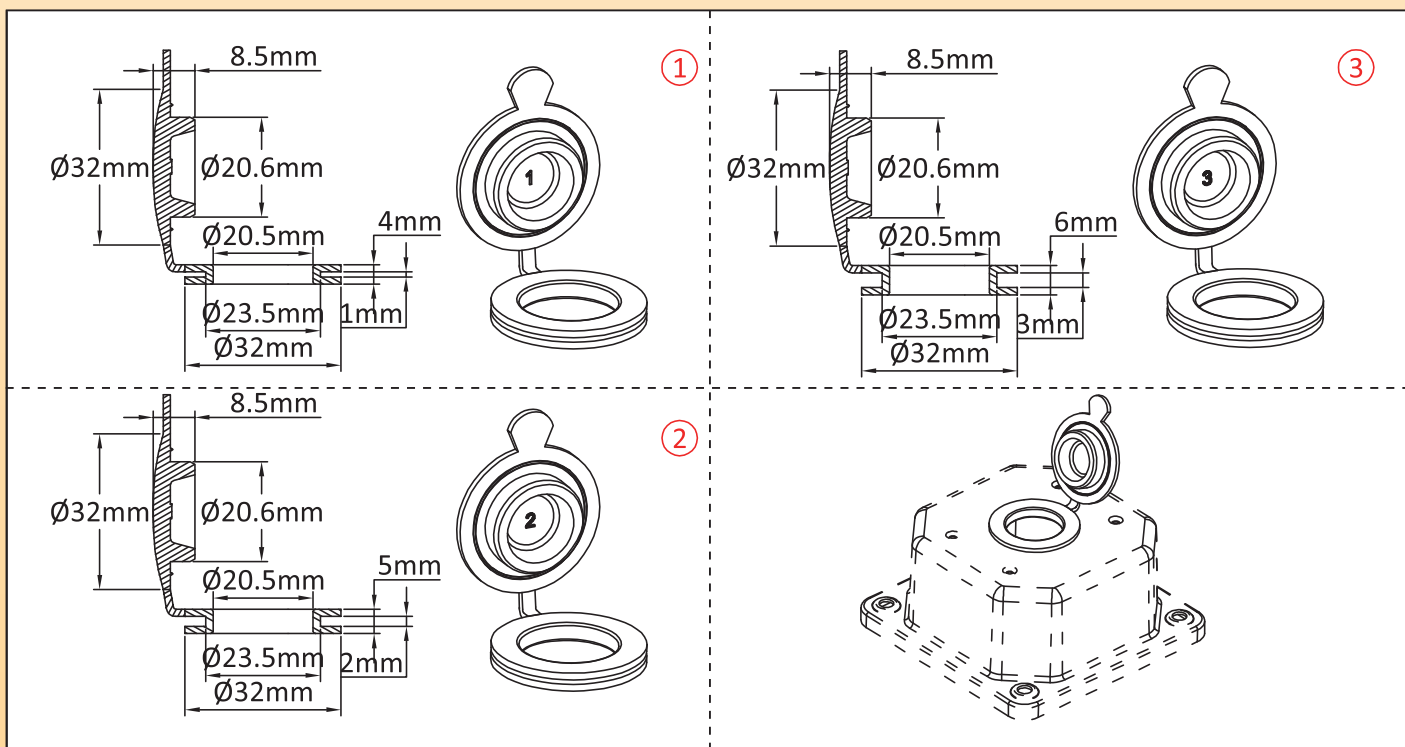

Compatible with:		
①	<input checked="" type="checkbox"/> Y3S3	<input checked="" type="checkbox"/> Y3S4
<input checked="" type="checkbox"/> Y3S5	<input checked="" type="checkbox"/> Y3S6	<input checked="" type="checkbox"/> Y3SA
<input checked="" type="checkbox"/> Y3SB	<input checked="" type="checkbox"/> Y3SC	<input checked="" type="checkbox"/> Y3TB
<input checked="" type="checkbox"/> Y3TC	<input checked="" type="checkbox"/> Y3S7	<input checked="" type="checkbox"/> Y3S8
<input checked="" type="checkbox"/> Y3S9	<input checked="" type="checkbox"/> Y3T8	<input checked="" type="checkbox"/> Y3TA
②		
③	<input checked="" type="checkbox"/> Y303	<input checked="" type="checkbox"/> Y304
<input checked="" type="checkbox"/> Y305	<input checked="" type="checkbox"/> Y3P1	<input checked="" type="checkbox"/> Y3P3
<input checked="" type="checkbox"/> Y3P6	<input checked="" type="checkbox"/> Y3P5	<input checked="" type="checkbox"/> Y306
<input checked="" type="checkbox"/> Y3C4	<input checked="" type="checkbox"/> Y307	<input checked="" type="checkbox"/> Y3M1



### Main references

Drawing	Wall thickness	References
①	1mm	66Q1S01235000000
②	2mm	66Q1S02235000000
③	3mm	66Q1S03235000000

### Links

	Page (.pdf)
	Drawing 2D (.dwg)
	Drawing 3D (.stp)

Model Nr 3: specify the knob temperature range printing

Red dimensions inside rectangular frames on drawings are used for assembly on enclosures or on fittings.

# Caps used on internal and external access to IP69K adjustment shafts, in PA66

Minimum Size	Maximum Size	Material	Type	Model
M25 × 1.5	M25 × 1.5	PA66	Plug	<b>66Q2</b> <b>66Q3</b>

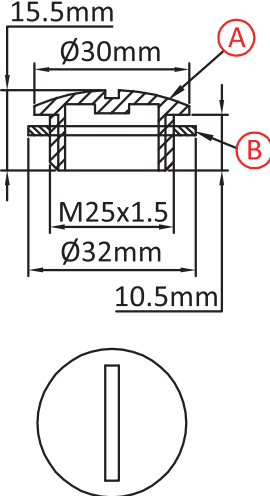
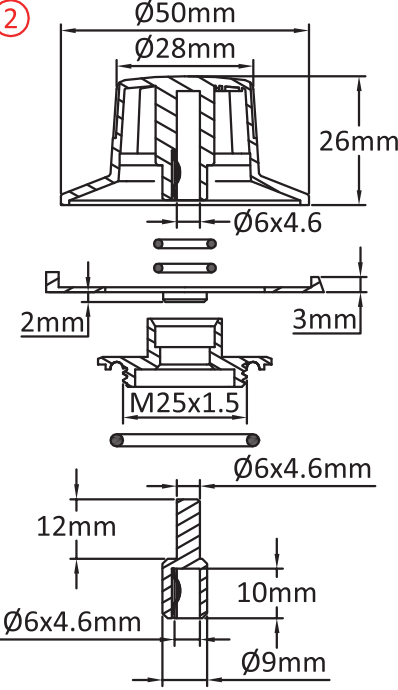
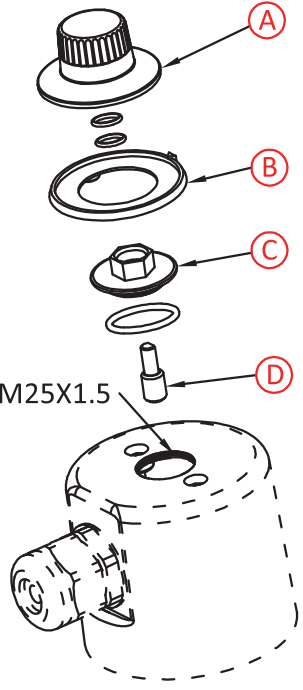

Compatible with:												
①												
<table border="0"> <tr> <td><input checked="" type="checkbox"/> Y3C3</td> <td><input checked="" type="checkbox"/> Y303</td> </tr> <tr> <td><input checked="" type="checkbox"/> Y304</td> <td><input checked="" type="checkbox"/> Y305</td> </tr> <tr> <td><input checked="" type="checkbox"/> Y3P1</td> <td><input checked="" type="checkbox"/> Y3P3</td> </tr> <tr> <td><input checked="" type="checkbox"/> Y3P6</td> <td><input checked="" type="checkbox"/> Y3P5</td> </tr> <tr> <td><input checked="" type="checkbox"/> Y306</td> <td><input checked="" type="checkbox"/> Y3C4</td> </tr> <tr> <td><input checked="" type="checkbox"/> Y307</td> <td><input checked="" type="checkbox"/> Y3M1</td> </tr> </table>			<input checked="" type="checkbox"/> Y3C3	<input checked="" type="checkbox"/> Y303	<input checked="" type="checkbox"/> Y304	<input checked="" type="checkbox"/> Y305	<input checked="" type="checkbox"/> Y3P1	<input checked="" type="checkbox"/> Y3P3	<input checked="" type="checkbox"/> Y3P6	<input checked="" type="checkbox"/> Y3P5	<input checked="" type="checkbox"/> Y306	<input checked="" type="checkbox"/> Y3C4
<input checked="" type="checkbox"/> Y3C3	<input checked="" type="checkbox"/> Y303											
<input checked="" type="checkbox"/> Y304	<input checked="" type="checkbox"/> Y305											
<input checked="" type="checkbox"/> Y3P1	<input checked="" type="checkbox"/> Y3P3											
<input checked="" type="checkbox"/> Y3P6	<input checked="" type="checkbox"/> Y3P5											
<input checked="" type="checkbox"/> Y306	<input checked="" type="checkbox"/> Y3C4											
<input checked="" type="checkbox"/> Y307	<input checked="" type="checkbox"/> Y3M1											
②												
<input checked="" type="checkbox"/> Y3C3												

<p>①</p> 	<p>②</p> 	
---	--	--

### Main references

### Links

①	② (A+B+C+D)	② (A+C+D)
66Q2PM1M25000000	66Q3PM3M25B00000	66Q3PM3M25K00000

	Page (.pdf)
	Drawing 2D (.dwg)
	Drawing 3D (.stp)

For the model N°2, please specify the printing requested on the knob.

Les dimensions encadrées en rouge sont celles utilisées pour le montage sur les boîtiers ou sur les raccords.

# Waterproof shaft gasket for external knob

Minimum Size	Maximum Size	Material	Type	Model
Dia. 10mm	Dia. 10mm	Silicone	Shaft gasket (IP54)	<b>66Q4</b>

### Compatible with:

- |  |  |
|--|--|
| <input checked="" type="checkbox"/> Y303 | <input checked="" type="checkbox"/> Y3C4 |
| <input checked="" type="checkbox"/> Y304 | <input checked="" type="checkbox"/> Y3P1 |
| <input checked="" type="checkbox"/> Y305 | <input checked="" type="checkbox"/> Y3P3 |
| <input checked="" type="checkbox"/> Y306 | <input checked="" type="checkbox"/> Y3P5 |
| <input checked="" type="checkbox"/> Y307 | <input checked="" type="checkbox"/> Y3M1 |



①

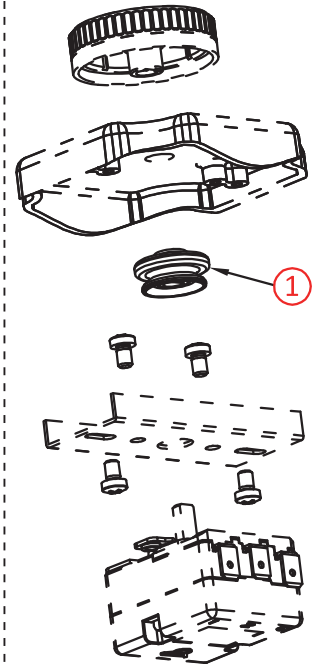
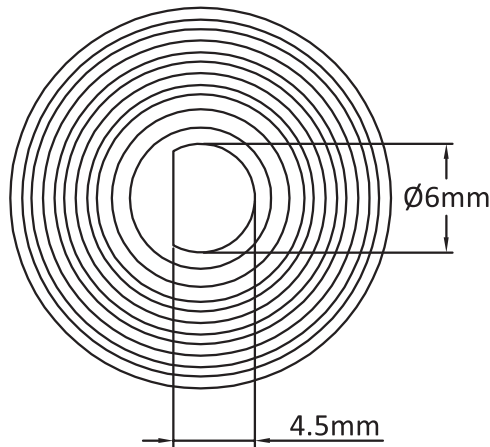
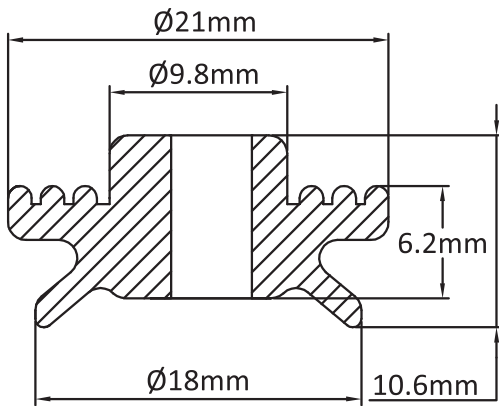

### Main reference

66Q4SM3100000000

### Links



Page  
(.pdf)



Drawing 2D  
(.dwg)





Drawing 3D  
(.stp)

Because of permanent improvement of our products, drawings, descriptions, features used on these data sheets are for guidance only and can be modified without prior advice

Red dimensions inside rectangular frames on drawings are used for assembly on enclosures or on fittings.

# Miniature connection blocks in PA66, one side screw terminals, one side solder terminals, surface mounting

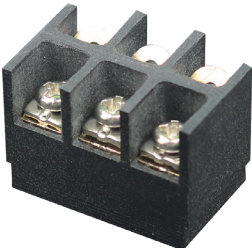
Minimum Size	Maximum Size	Material	Type	Model
16 × 19 × 27mm	16 × 19 × 44mm	PA66	2.5mm <sup>2</sup> connection block, surface mounting	<b>BEN BEO</b>

Compatible with:	
①	
<input checked="" type="checkbox"/> Y3A1 <input checked="" type="checkbox"/> Y3A2	
②	
<input checked="" type="checkbox"/> Y3A3	

①

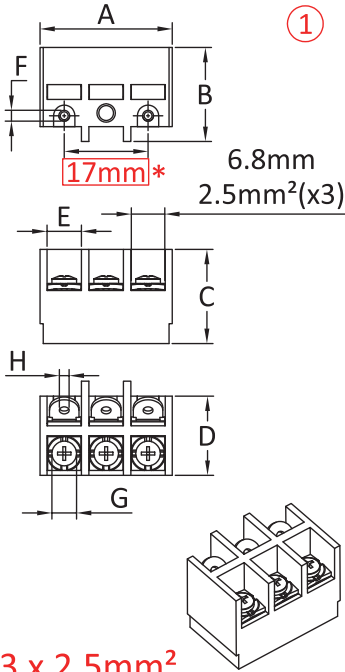

3 x 2.5mm<sup>2</sup>

②

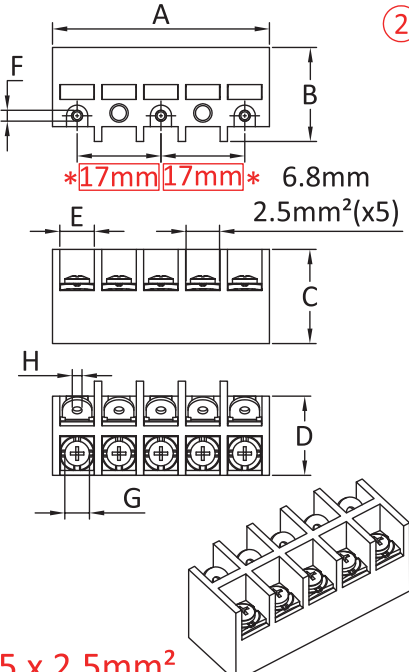



5 x 2.5mm<sup>2</sup>

	2.5mm <sup>2</sup> (x3)	2.5mm <sup>2</sup> (x5)
A	27	44
B	19	19
C	19	19
D	16	16
E	7(x3)	7(x5)
F	Holes for ST2.2(x2)	Holes for ST2.2(x3)
G	M3(x3)	M3(x5)
H	∅2(x3)	∅2(x5)

## Main references

①	②
BENF3K3000000P00	BEOF3K3000000P00



## Links

	Page (.pdf)
	Drawing 2D (.dwg)
	Drawing 3D (.stp)

Red dimensions inside rectangular frames on drawings are used for assembly on enclosures or on fittings.

# Special elevated PA66 connection blocks, screw terminals on both sides

Minimum Size	Maximum Size	Material	Type	Model
22 × 40 × 27mm	52 × 46.5 × 40mm	PA66	Special design 2.5mm <sup>2</sup> connection block	<b>BEJ BEL</b>

Compatible with:	①	②
<div style="border: 1px solid black; padding: 2px;"> <span style="color: red;">①</span> </div> <input checked="" type="checkbox"/> Y301		
<div style="border: 1px solid black; padding: 2px;"> <span style="color: red;">②</span> </div> <input checked="" type="checkbox"/> Y3C1 <input checked="" type="checkbox"/> Y3C2		

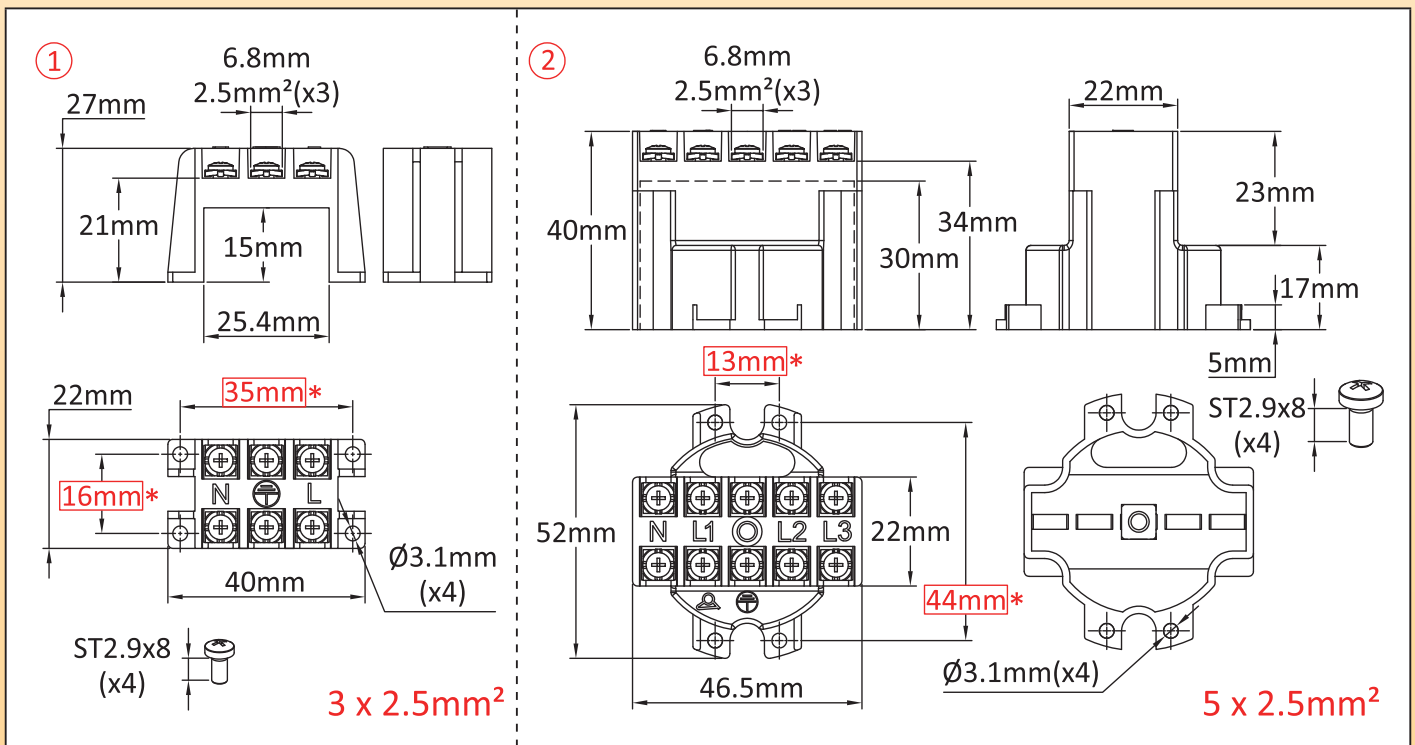

## Main references

①	②
BEJF3F3000000P00	BELF5F5000000P00

## Links



Page  
(.pdf)



Drawing 2D  
(.dwg)



Drawing 3D  
(.stp)

Red dimensions inside rectangular frames on drawings are used for assembly on enclosures or on fittings.

# 14mm elevated connection blocks, screw terminals on both sides

Minimum Size	Maximum Size	Material	Type	Model
22 × 65 × 26.5MM	22 × 95 × 26.5mm	PA66	Elevated 2.5mm <sup>2</sup> connection block	<b>BEP BEQ BER</b>

Compatible with:	
①	
<input checked="" type="checkbox"/> Y3P1	<input checked="" type="checkbox"/> Y3P3
②	
<input checked="" type="checkbox"/> Y3F1	<input checked="" type="checkbox"/> Y3F2
<input checked="" type="checkbox"/> Y3F3	<input checked="" type="checkbox"/> Y3C6
<input checked="" type="checkbox"/> Y3C7	<input checked="" type="checkbox"/> Y3C8
<input checked="" type="checkbox"/> Y305	<input checked="" type="checkbox"/> Y3P4
<input checked="" type="checkbox"/> Y3S5	<input checked="" type="checkbox"/> Y3S6
③	
<input checked="" type="checkbox"/> Y3P6	<input checked="" type="checkbox"/> Y3P5

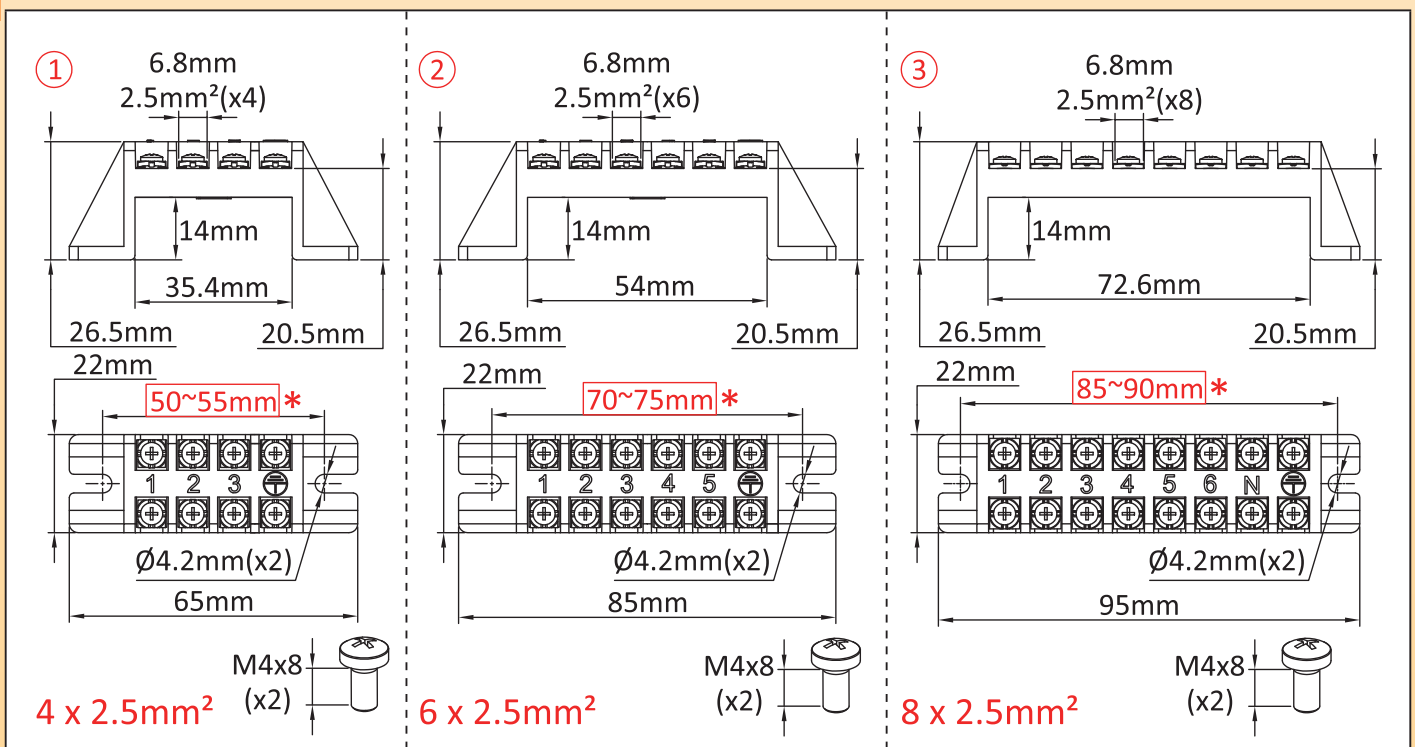
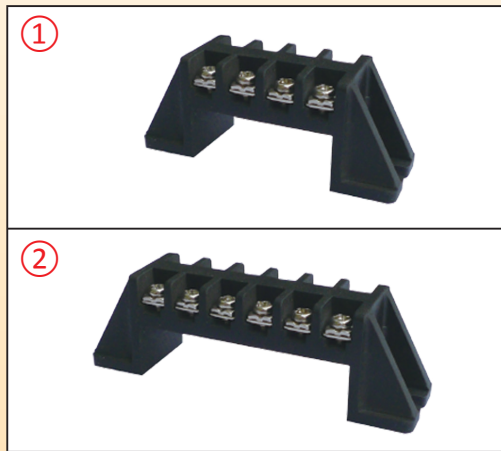

## Main references

①	②	③
BEPF4F4000000P00	BEQF6F6000000P00	BERF8F8000000P00

## Links

	Page (.pdf)
	Drawing 2D (.dwg)
	Drawing 3D (.stp)

Red dimensions inside rectangular frames on drawings are used for assembly on enclosures or on fittings.



# Snap-On PA66 terminal, for large enclosures, mixed size terminals

Minimum Size	Maximum Size	Material	Type	Model
119 × 49.5 × 34mm	119 × 49.5 × 34mm	PA66	Mixed terminal sizes snap-on connection blocks	<b>BES</b> <b>BET</b>

Compatible with:	①	②
<input checked="" type="checkbox"/> Y3G1 <input checked="" type="checkbox"/> Y3G2 <input checked="" type="checkbox"/> Y307 <input checked="" type="checkbox"/> Y309 <input checked="" type="checkbox"/> Y310 <input checked="" type="checkbox"/> Y3J1 <input checked="" type="checkbox"/> Y3J2 <input checked="" type="checkbox"/> Y3M1 <input checked="" type="checkbox"/> Y3N1		

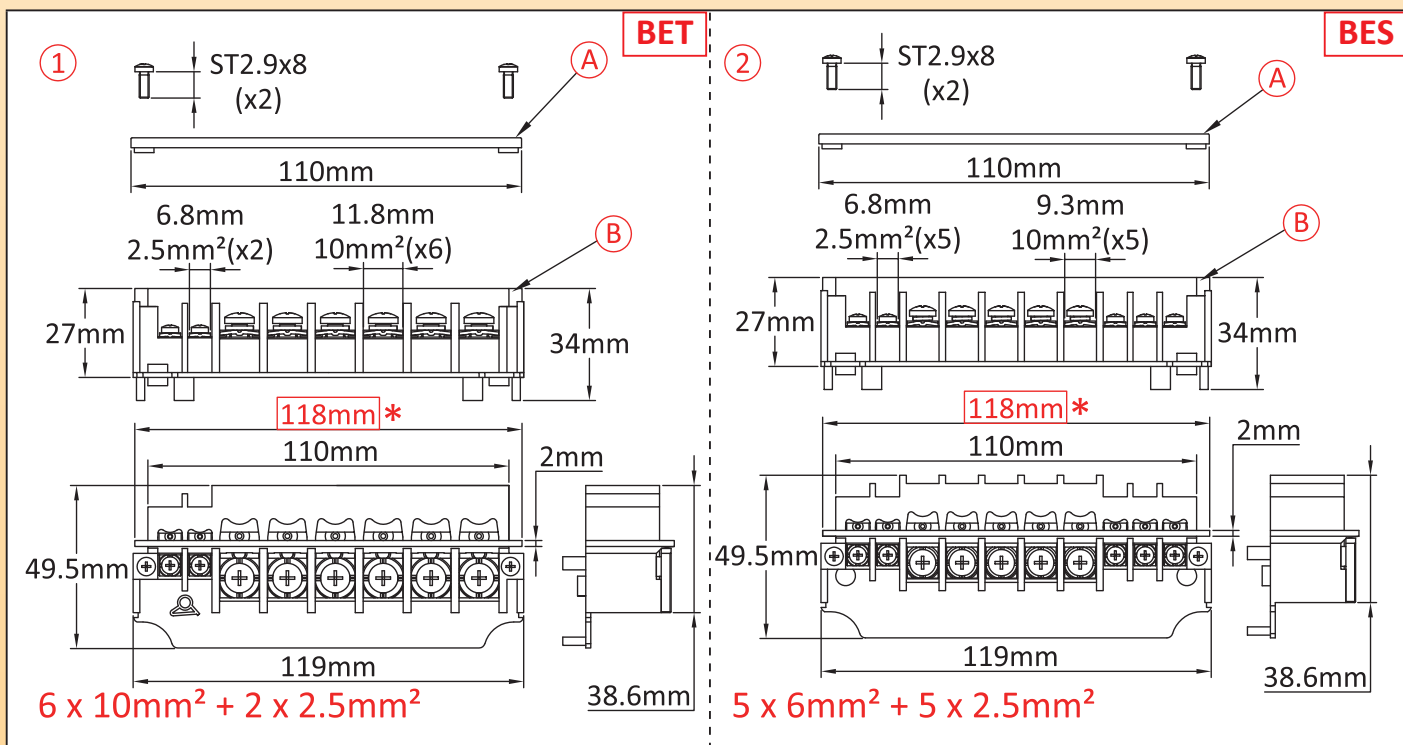

## Main references

① (A+B)	① (B)	② (A+B)	② (B)
BETLAQA000000P01	BETLAQA000000P00	BESMAPA000000P01	BESMAPA000000P00

## Links



Page  
(.pdf)



Drawing 2D  
(.dwg)



Drawing 3D  
(.stp)

Red dimensions inside rectangular frames on drawings are used for assembly on enclosures or on fittings.

# Dia. 55mm immersion heaters thermowells, without thread, for corrosive baths

Minimum Size	Maximum Size	Material	Type	Model
Dia. 55 × 110mm	Dia. 55 × 1000mm	316 stainless steel Titanium	Pocket with compression type gasket	<b>66TTW8</b> <b>66TNW8</b>

Compatible with:	
<input checked="" type="checkbox"/> Y3C6	<input checked="" type="checkbox"/> Y3E6
<input checked="" type="checkbox"/> Y3C7	<input checked="" type="checkbox"/> Y3E7
<input checked="" type="checkbox"/> Y3C8	<input checked="" type="checkbox"/> Y3E8
<input checked="" type="checkbox"/> Designed to fit dia. 52mm steatite heating elements.	

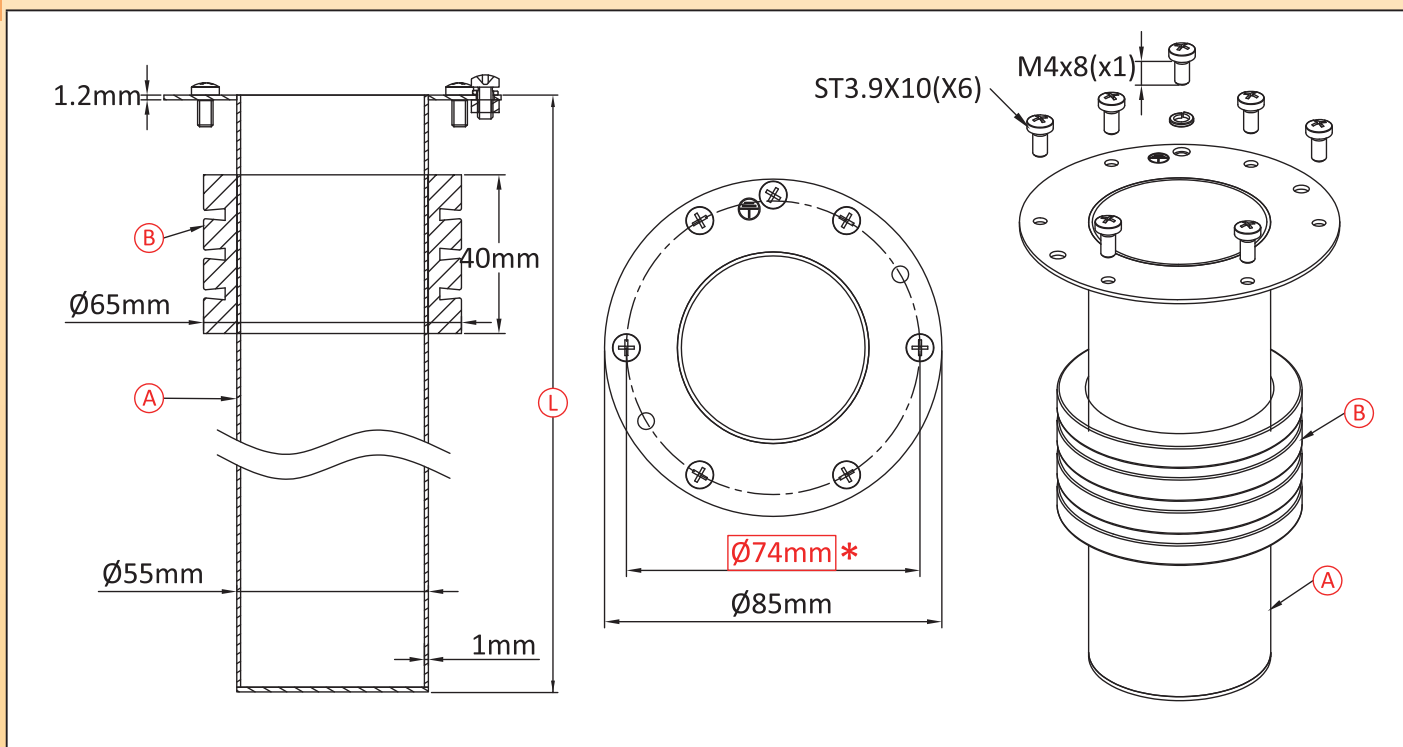

### Main references

(A)	(B)	(L)	References
316L	Silicone	450mm	66TTW800450A550S
316L	Silicone	600mm	66TTW800600A550S
316L	Silicone	800mm	66TTW800800A550S
316L	FKM(Viton)	450mm	66TTW800450A550K
316L	FKM(Viton)	600mm	66TTW800600A550K
316L	FKM(Viton)	800mm	66TTW800800A550K
Titanium	FKM(Viton)	450mm	66TNW800450A550K
Titanium	FKM(Viton)	600mm	66TNW800600A550K
Titanium	FKM(Viton)	800mm	66TNW800800A550K

### Links

	Page (.pdf)
	Drawing 2D (.dwg)
	Drawing 3D (.stp)

L length can be made on request. Gasket B can be made in NBR.

Red dimensions inside rectangular frames on drawings are used for assembly on enclosures or on fittings.

# Dia. 55mm immersion heaters thermowells, with 2"1/2 and M77x2 threads

Minimum Size	Maximum Size	Material	Type	Model
2½", L=110mm	M77 × 2, L=1000mm	316 stainless steel	Threaded pocket	<b>66UT</b>

**Compatible with:**

<input checked="" type="checkbox"/> Y3S7	<input checked="" type="checkbox"/> Y309
<input checked="" type="checkbox"/> Y3SA	<input checked="" type="checkbox"/> Y310
<input checked="" type="checkbox"/> Y3G1	<input checked="" type="checkbox"/> Y3J1
<input checked="" type="checkbox"/> Y3G2	<input checked="" type="checkbox"/> Y3J2
	<input checked="" type="checkbox"/> Y3M1

Designed to fit dia. 52mm steatite heating elements

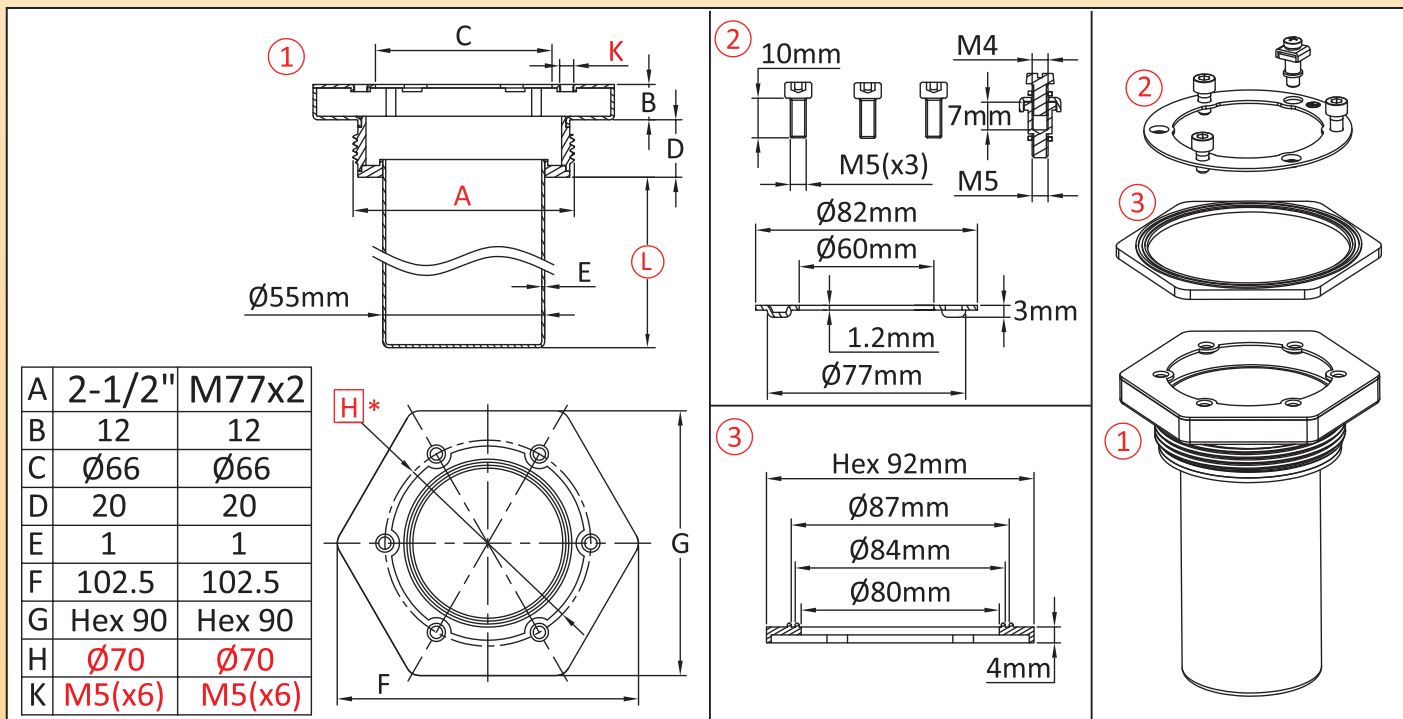

### Main references

Ⓐ	Ⓛ	①	①+②+③
2-1/2"	450	66UT0035450A5500	66UT0035450A550A
2-1/2"	600	66UT0035600A5500	66UT0035600A550A
2-1/2"	800	66UT0035800A5500	66UT0035800A550A
M77x2	450	66UTW335450A5500	66UTW335450A550A
M77x2	600	66UTW335600A5500	66UTW335600A550A
M77x2	800	66UTW335800A5500	66UTW335800A550A

### Links



Page  
(.pdf)



Drawing 2D  
(.dwg)



Drawing 3D  
(.stp)

The length L can be made on request. Gasket N°3 is in silicone in standard. Can be made in NBR or FKM on request.  
Red dimensions inside rectangular frames on drawings are used for assembly on enclosures or on fittings.

# Dia. 25mm immersion heaters thermowells, without thread, for corrosive baths

Minimum Size	Maximum Size	Material	Type	Model
Dia. 25 × 110mm	Dia. 25 × 1000mm	316 stainless steel Titanium	Pocket with compression type gasket	<b>66TTL4</b> <b>66TNL4</b>

Compatible with:

☒ 66RW

☒ 66RY

☒ Designed to fit 25mm cartridge heaters or 25mm dia. pockets.



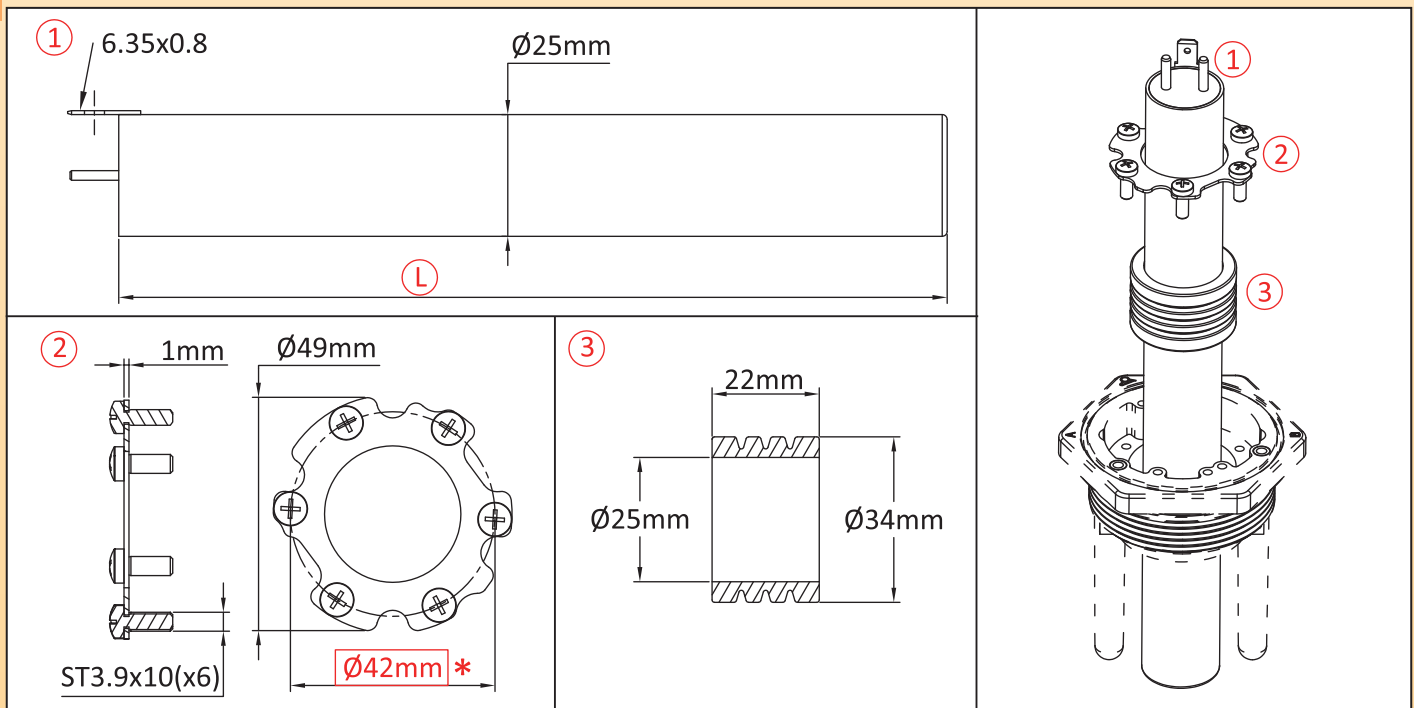

### Main references

With empty dia. 25mm pocket			
①	③	①	References(①+②+③)
316L	Silicone	450mm	66TTL4264507250S
316L	Silicone	600mm	66TTL4266007250S
316L	Silicone	800mm	66TTL4268007250S
316L	FKM(Viton)	450mm	66TTL4264507250K
316L	FKM(Viton)	600mm	66TTL4266007250K
316L	FKM(Viton)	800mm	66TTL4268007250K
Titanium	FKM(Viton)	450mm	66TNL4264507250K
Titanium	FKM(Viton)	600mm	66TNL4266007250K
Titanium	FKM(Viton)	800mm	66TNL4268007250K

Gasket and ring only, for customer's own cartridge heater

Reference(②+③) with silicone gasket

66TOL4260000000S

Reference(②+③) with FKM gasket

66TOL4260000000K

### Links



Page (.pdf)



Drawing 2D (.dwg)



Drawing 3D (.stp)

L length can be made on request. Gasket 3 can be made in NBR.

Red dimensions inside rectangular frames on drawings are used for assembly on enclosures or on fittings.

# 10mm diameter pockets for temperature sensors, thermostats or level detectors, without thread, for corrosive baths

Minimum Size	Maximum Size	Material	Type	Model
Dia. 10 × 110mm	Dia. 10 × 1000mm	316 stainless steel 316 with PTFE sleeving Titanium	Pocket with compression type gasket	<b>66TTW3</b> <b>66TNW3</b>

**Compatible with:**

- Y3C8
- Y3E8
  
- Designed to receive thermostats bulbs or temperature sensors.

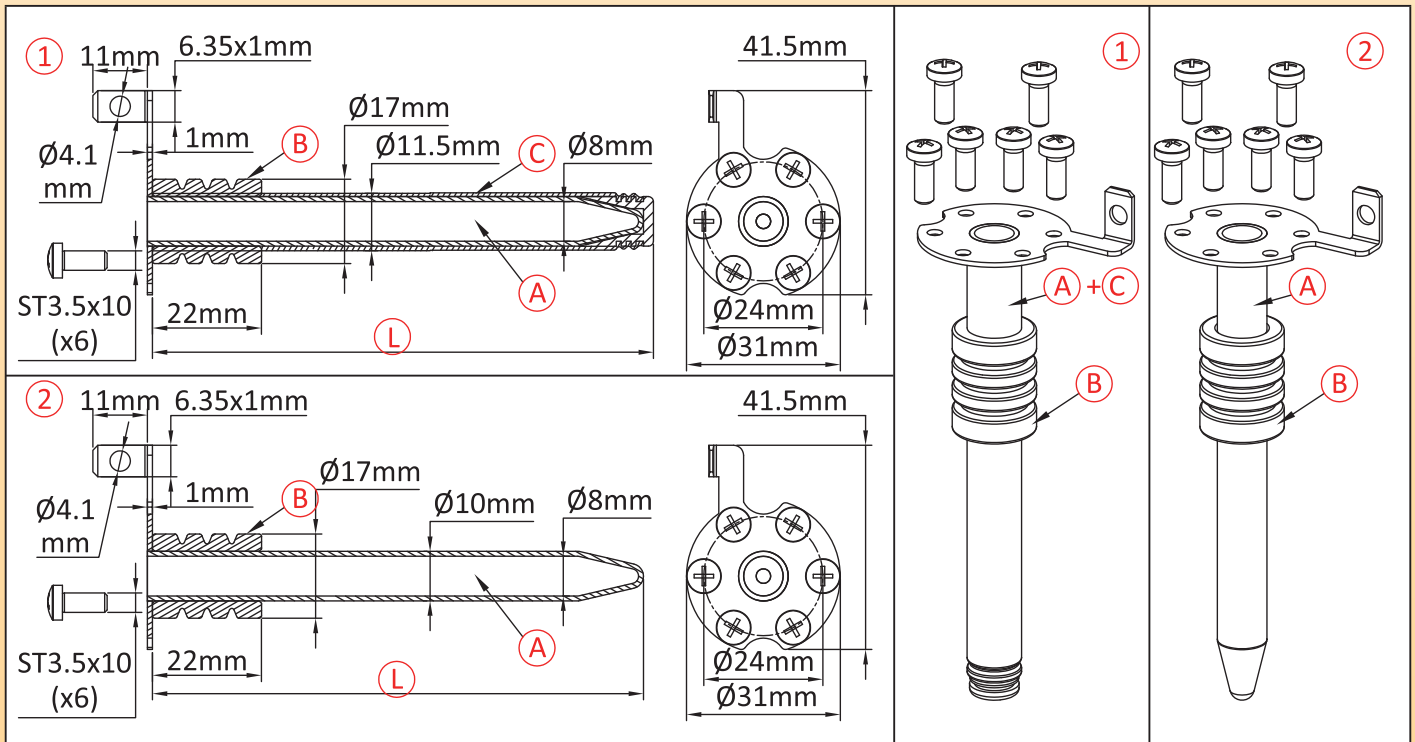

### Main references

Model ② without sleeving			Model ① with sleeving		
(A)	(B)	(L)	References	(C)	References
316L	Silicone	230mm	66TTW300230A100S	PTFE	66TTW300230A1B0S
316L	Silicone	300mm	66TTW300300A100S	PTFE	66TTW300300A1B0S
316L	Silicone	450mm	66TTW300450A100S	PTFE	66TTW300450A1B0S
316L	Silicone	600mm	66TTW300600A100S	PTFE	66TTW300600A1B0S
316L	FKM(Viton)	230mm	66TNW300230A100K	PTFE	66TNW300230A1B0K
316L	FKM(Viton)	300mm	66TNW300300A100K	PTFE	66TNW300300A1B0K
316L	FKM(Viton)	450mm	66TNW300450A100K	PTFE	66TNW300450A1B0K
316L	FKM(Viton)	600mm	66TNW300600A100K	PTFE	66TNW300600A1B0K

### Links

Page  
(.pdf)

Drawing 2D  
(.dwg)

Drawing 3D  
(.stp)

Because of permanent improvement of our products, drawings, descriptions, features used on these data sheets are for guidance only and can be modified without prior advice

L length can be made on request. Gasket B can be made in NBR. Diameters smaller than 10mm available on request.  
**Red dimensions inside rectangular frames on drawings are used for assembly on enclosures or on fittings.**

# Stainless steel fittings, machined and welded threads with deep drawn flange, for immersion heaters

Minimum Size	Maximum Size	Material	Type	Model
1½"	M77 × 2	AISI 304 AISI 316	Tig welded thread for enclosure	<b>66YS</b>

Compatible with:

Y3S6       Y3SB  
 Y3S8       Y3SC  
 Y3S9

Designed for direct welding on enclosures or deep drawn fittings with soldering lip.



	1-1/2"	M45x2	2-1/2"	M77x2
A	Ø43	Ø43	Ø72	Ø72
B	Ø40.5	Ø40.5	Ø69.5	Ø69.5
C	Ø38	Ø38	Ø66.5	Ø66.5
D	1-1/2"	M45x2	2-1/2"	M77x2
E	3.7	3.7	3.7	3.7
F	Ø8.6(x0,x1) Ø10(x0,x1)	Ø8.6(x0,x1) Ø10(x0,x1)	Ø8.6(x0,x1,x2) Ø10(x0,x1,x2) Ø12(x0,x1,x2)	Ø8.6(x0,x1,x2) Ø10(x0,x1,x2) Ø12(x0,x1,x2)
G	Ø6(x2,x4,x6) Ø8(x2,x4,x6)	Ø6(x2,x4,x6) Ø8(x2,x4,x6)	Ø8(x2,x4,x6) Ø10(x2,x4,x6) Ø12(x2,x4,x6)	Ø8(x2,x4,x6) Ø10(x2,x4,x6) Ø12(x2,x4,x6)
H	22	22	22	22
I	21.5	21.5	21.5	21.5

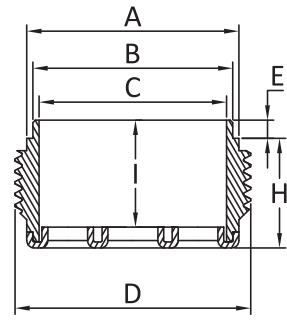

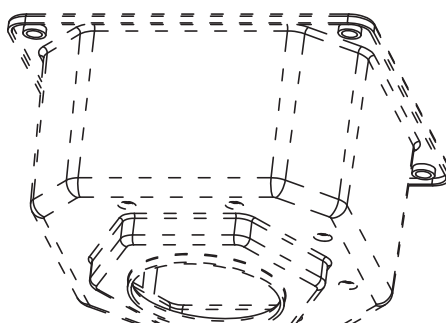

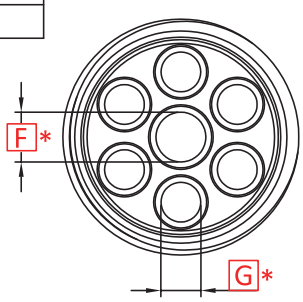

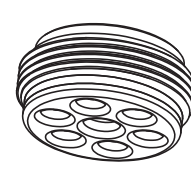



### Main references

Dimensions	References in 304	References in 316
1-1/2"	66YSC112I22*****	66YSC112T22*****
M45x2	66YSM452I22*****	66YSM452T22*****
2-1/2"	66YSC212I22*****	66YSC212T22*****
M77x2	66YSM772I22*****	66YSM772T22*****

### Links

Page (.pdf)

Drawing 2D (.dwg)

Drawing 3D (.stp)

Specify dimensions and quantity of holes F and G.

Red dimensions inside rectangular frames on drawings are used for assembly on enclosures or on fittings.

# Stainless steel fittings, machined and welded threads for immersion heaters

Minimum Size	Maximum Size	Material	Type	Model
1½"	M77 × 2	AISI 304 AISI 316	Plain fitting for enclosure	<b>66YU</b>

Compatible with:	
<input checked="" type="checkbox"/> Y3S6	<input checked="" type="checkbox"/> Y3SB
<input checked="" type="checkbox"/> Y3S8	<input checked="" type="checkbox"/> Y3SC
<input checked="" type="checkbox"/> Y3S9	
<input checked="" type="checkbox"/> Designed for direct welding on enclosures or deep drawn fittings with soldering lip.	

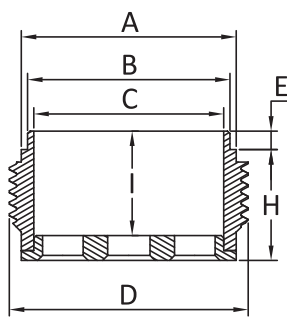
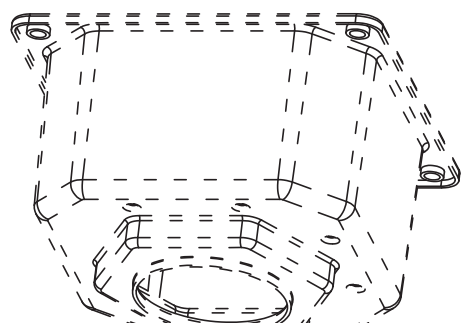
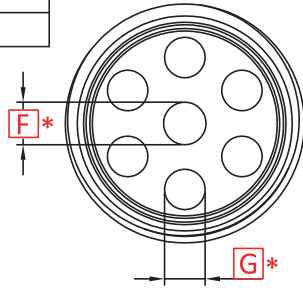

	1-1/2"	M45x2	2-1/2"	M77x2
A	Ø43	Ø43	Ø72	Ø72
B	Ø40.5	Ø40.5	Ø69.5	Ø69.5
C	Ø38	Ø38	Ø66.5	Ø66.5
D	1-1/2"	M45x2	2-1/2"	M77x2
E	3.7	3.7	3.7	3.7
F	Ø8.6(x0,x1) Ø10(x0,x1)	Ø8.6(x0,x1) Ø10(x0,x1)	Ø8.6(x0,x1,x2) Ø10(x0,x1,x2) Ø12(x0,x1,x2)	Ø8.6(x0,x1,x2) Ø10(x0,x1,x2) Ø12(x0,x1,x2)
G	Ø6(x2,x4,x6) Ø8(x2,x4,x6)	Ø6(x2,x4,x6) Ø8(x2,x4,x6)	Ø8(x2,x4,x6) Ø10(x2,x4,x6) Ø12(x2,x4,x6)	Ø8(x2,x4,x6) Ø10(x2,x4,x6) Ø12(x2,x4,x6)
H	22	22	22	22
I	21	21	21	21

## Main references

Dimensions	References in 304	References in 316
1-1/2"	66YUC112I22*****	66YUC112T22*****
M45x2	66YUM452I22*****	66YUM452T22*****
2-1/2"	66YUC212I22*****	66YUC212T22*****
M77x2	66YUM772I22*****	66YUM772T22*****

## Links



Page  
(.pdf)



Drawing 2D  
(.dwg)



Drawing 3D  
(.stp)

Because of permanent improvement of our products, drawings, descriptions, features used on these data sheets are for guidance only and can be modified without prior advice

Specify dimensions and quantity of holes F and G.

**Red dimensions inside rectangular frames on drawings are used for assembly on enclosures or on fittings.**

# Stainless steel, machined threads for temperature sensors and level sensors

Minimum Size	Maximum Size	Material	Type	Model
1/2"	3/4"	AISI 304 AISI 316	Plain fitting for enclosure	<b>66YQ</b>

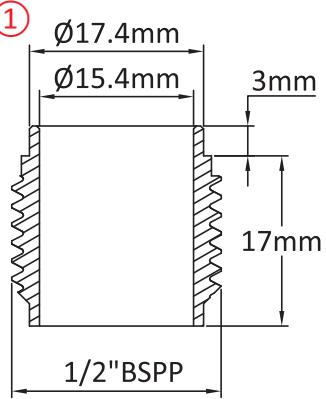
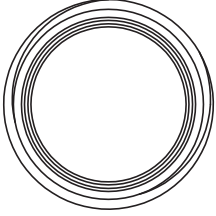
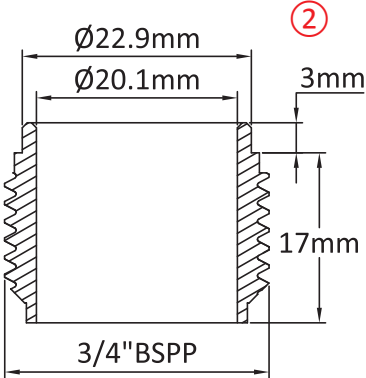
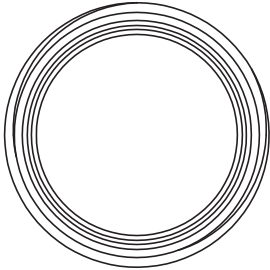
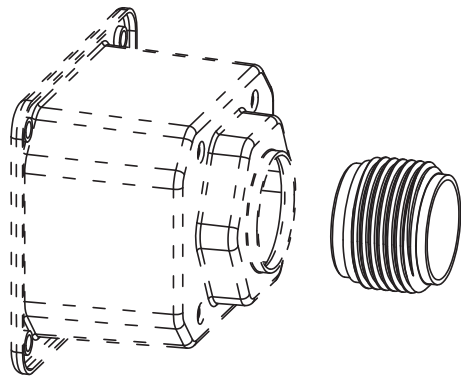

<b>Compatible with:</b> ① <input checked="" type="checkbox"/> Y3L2 ② <input checked="" type="checkbox"/> Y3L2 <input checked="" type="checkbox"/> Designed for direct welding on deep drawn stainless steel enclosures with soldering lip.	① 	② 
---	--	--

①  	②  	
--	--	---

### Main references

Dimensions	References in 304	References in 316
1/2"	66YQC012I1710000	66YQC012T1710000
3/4"	66YQC034I1710000	66YQC034T1710000

### Links

	Page (.pdf)
	Drawing 2D (.dwg)
	Drawing 3D (.stp)

Red dimensions inside rectangular frames on drawings are used for assembly on enclosures or on fittings.



# Split nuts for spa and swimming pool heaters. Exist for 2" BSPP, 2" 1/2 and 3" Ansi B1.9 threads (USA)

Minimum Size	Maximum Size	Material	Type	Model
2"(BSPP)	3"(ANSI)	ABS	Split nut	<b>66NS</b>

<p><b>Compatible with:</b></p> <ul style="list-style-type: none"> <li><input checked="" type="checkbox"/> 66RW</li> <li><input checked="" type="checkbox"/> 66RY</li>   <li><input checked="" type="checkbox"/> Designed to connect spa, swimming pools and aquarium heaters in stainless steel tube, on PVC fittings.</li> </ul>	<p>①</p> 	<p>②</p> 	<p>③</p> 
---	--	---	--

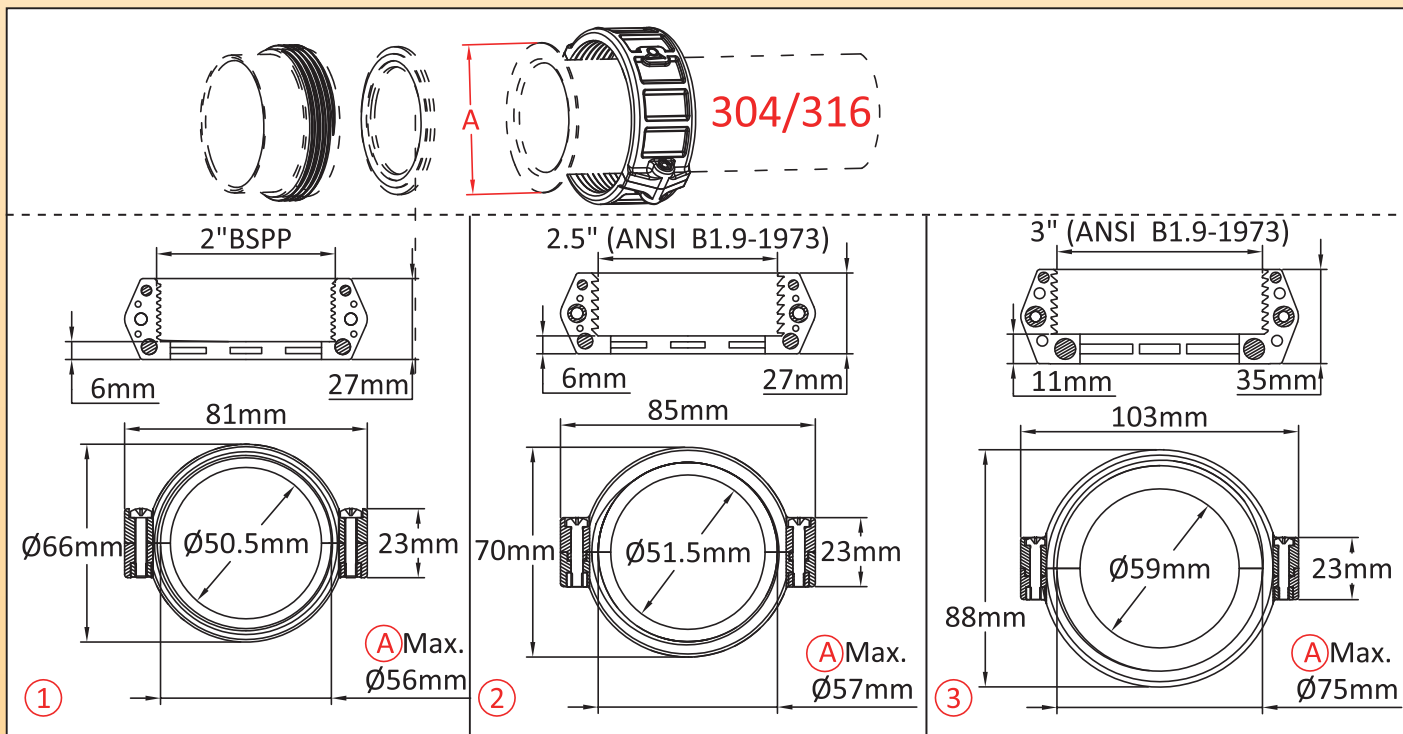

### Main references

### Links

①	②	③
66NSC20060R66000	66NSA25060R70000	66NSA300A1R80000



Page  
(.pdf)



Drawing 2D  
(.dwg)



Drawing 3D  
(.stp)

Red dimensions inside rectangular frames on drawings are used for assembly on enclosures or on fittings.

# Shutters of deep drawn stainless steel fittings

Minimum Size	Maximum Size	Material	Type	Model
1¼"	2½"	PA66	Shutter	66Z1 66Z2

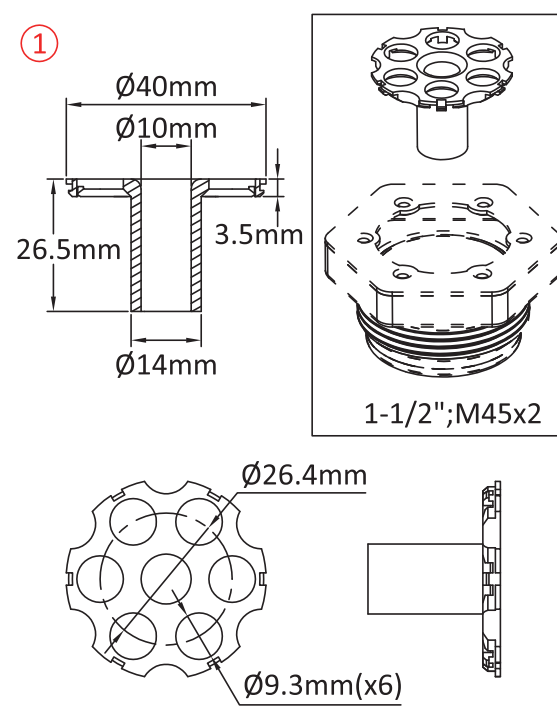
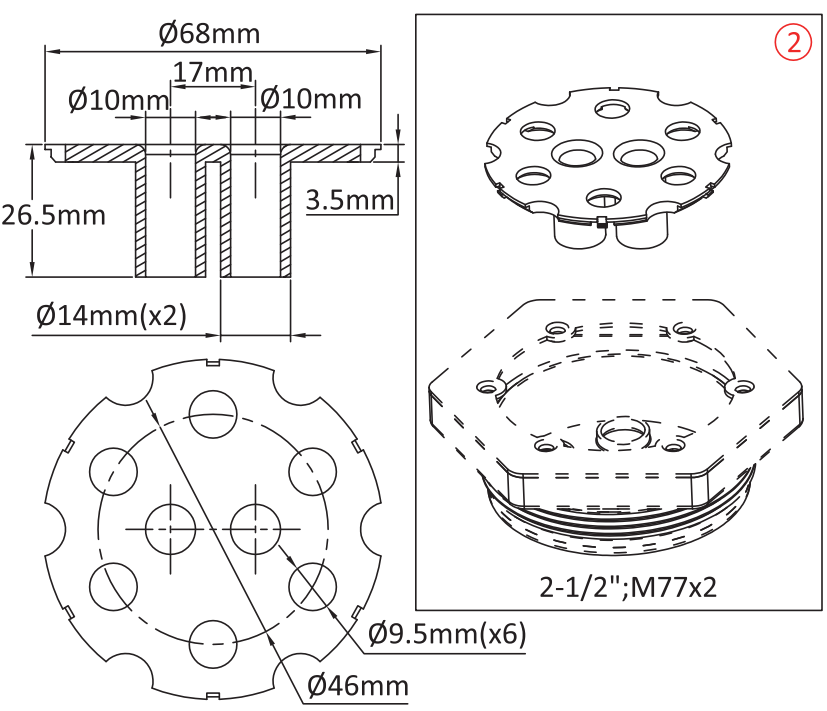

Compatible with:	①	②
<input checked="" type="checkbox"/> 66RJ <input checked="" type="checkbox"/> 66RK <input checked="" type="checkbox"/> 66RO <input checked="" type="checkbox"/> 66RP <input checked="" type="checkbox"/> 66RQ <input checked="" type="checkbox"/> 66RR <input checked="" type="checkbox"/> 66RU <input checked="" type="checkbox"/> 66RV <input checked="" type="checkbox"/> Designed to close deep drawn stainless steel fittings after heating elements soldering.		

①	②
 <p style="text-align: center;">1-1/2"; M45x2</p>	 <p style="text-align: center;">2-1/2"; M77x2</p>

### Main references

①	②
66Z1P60931010265	66Z2P60952010265

### Links

	Page (.pdf)
	Drawing 2D (.dwg)
	Drawing 3D (.stp)

Red dimensions inside rectangular frames on drawings are used for assembly on enclosures or on fittings.

**PCB with one miniature relay, rating 16A 250V. Allows to increase the rating of devices using reed switches.**

Minimum Size	Maximum Size	Material	Type	Model
45 × 27 × 23mm	45 × 27 × 23mm	PCB	Relay boards	<b>6YRM</b>

Compatible with:

Y3A2

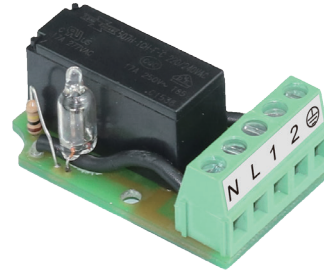

Because of permanent improvement of our products, drawings, descriptions, features used on these data sheets are for guidance only and can be modified without prior advice

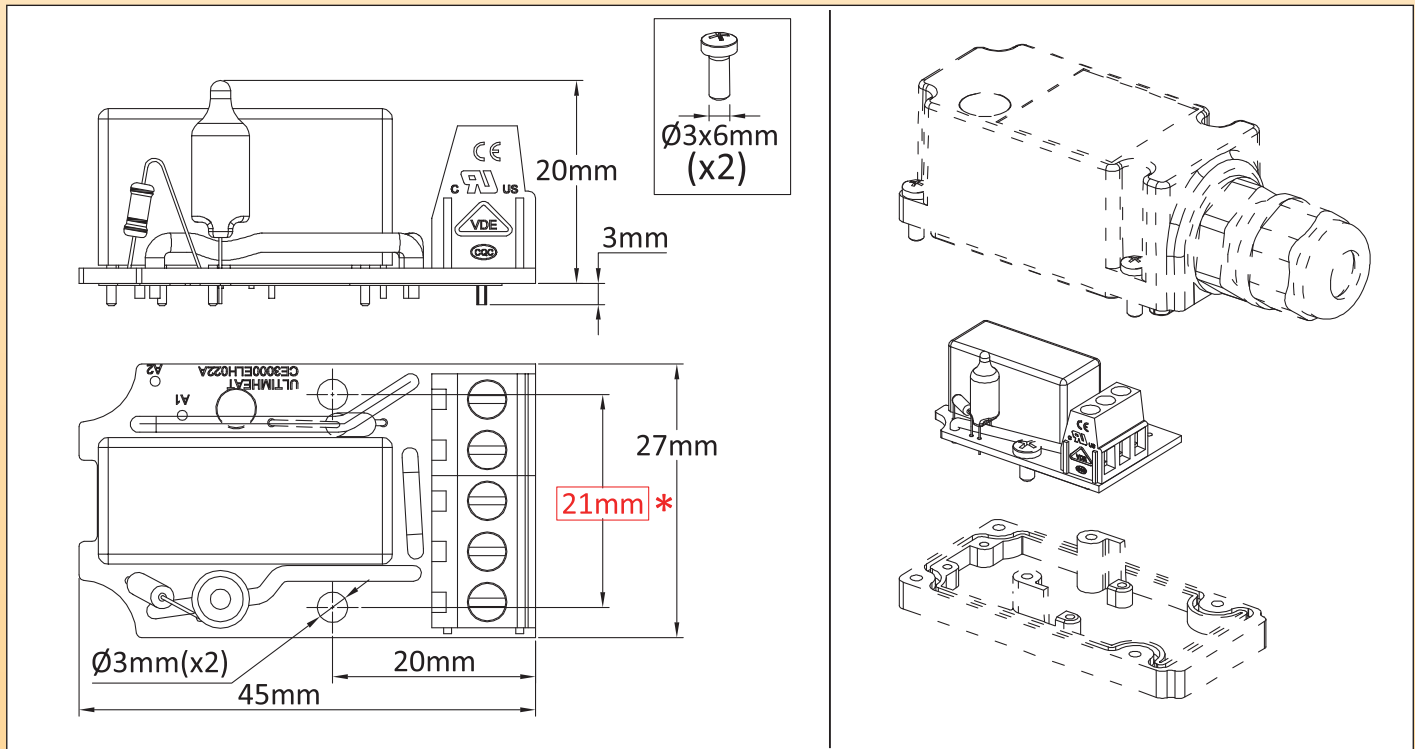

**Main reference**

6YRMA230116MF000

**Links**



Page  
(.pdf)



Drawing 2D  
(.dwg)



Drawing 3D  
(.stp)

Red dimensions inside rectangular frames on drawings are used for assembly on enclosures or on fittings.

# Relay boards, with 2 to 3 miniature relays, rating 16A 250V, coil 220/240V. One of their application is to convert single pole devices into 3 poles

Minimum Size	Maximum Size	Material	Type	Model
<b>38 × 60 × 19.4mm</b>	<b>31 × 70 × 19.4mm</b>	<b>PCB</b>	<b>Relay boards</b>	<b>6YRC</b>

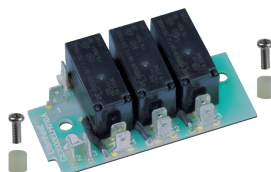
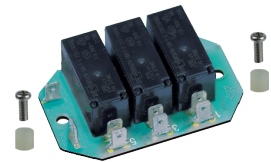
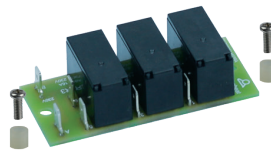

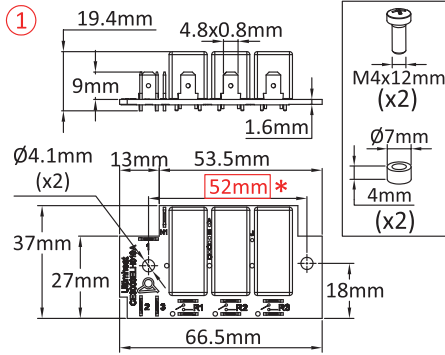
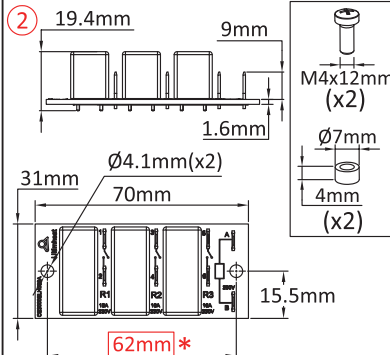
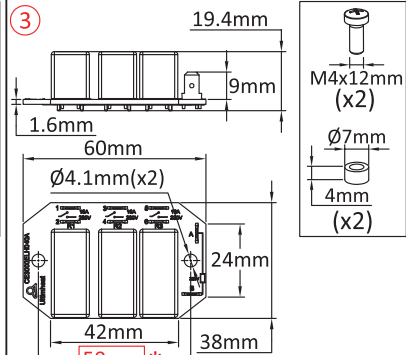
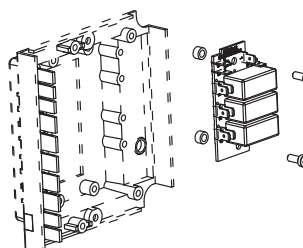
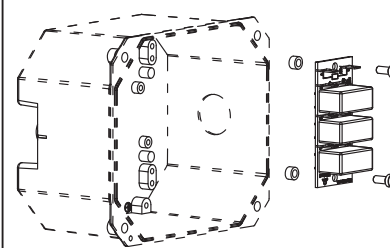
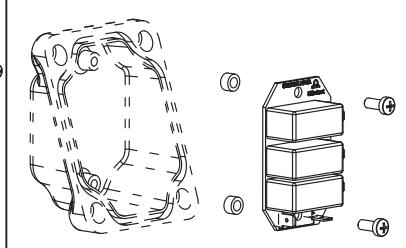
<b>① Model 1 compatible with:</b> <input checked="" type="checkbox"/> Y3N2 <input checked="" type="checkbox"/> Y310 <input checked="" type="checkbox"/> Y3N3 <input checked="" type="checkbox"/> Y3G2 <input checked="" type="checkbox"/> Y3N4 <input checked="" type="checkbox"/> Y3J2 <input checked="" type="checkbox"/> Y309	<b>①</b> 	<b>③</b> 
<b>② Model 2 compatible with:</b> <input checked="" type="checkbox"/> Y3P6	<b>②</b> 	
<b>③ Model 3 compatible with:</b> <input checked="" type="checkbox"/> Y303 <input checked="" type="checkbox"/> Y305 <input checked="" type="checkbox"/> Y304 <input checked="" type="checkbox"/> Y3P5		

<b>①</b> 	<b>②</b> 	<b>③</b> 
		

### Main references

### Links

Model	Quantity of relays	Independent relays	Coupled relays
<b>①</b>	2	6YRCD230216SF000	6YRCD230216PF000
<b>①</b>	3	6YRCD230316SF000	6YRCD230316PF000
<b>②</b>	2	6YRCB230216NF000	6YRCB230216PF000
<b>②</b>	3	6YRCB230316NF000	6YRCB230316PF000
<b>③</b>	2	6YRCE230216NF000	6YRCE230216PF000
<b>③</b>	3	6YRCE230316NF000	6YRCE230316PF000

	Page (.pdf)
	Drawing 2D (.dwg)
	Drawing 3D (.stp)

The relay coil is 230V 50 Hz. 24V on request. Maximum load 16A resistive, 100000 cycles. Maximum potential difference between contacts: 250V AC

Red dimensions inside rectangular frames on drawings are used for assembly on enclosures or on fittings.

# Relay boards, with 4 to 6 miniature relays, rating 16A 250V, coil 220/240V. One of their application is to convert single pole devices into 3 poles

Minimum Size	Maximum Size	Material	Type	Model
37 × 115 × 19.4mm	37 × 115 × 19.4mm	PCB	Relay boards	<b>6YRE</b>

**Compatible with:**

<input checked="" type="checkbox"/> Y3N2	<input checked="" type="checkbox"/> Y309
<input checked="" type="checkbox"/> Y3N3	<input checked="" type="checkbox"/> Y3J2
<input checked="" type="checkbox"/> Y3N4	<input checked="" type="checkbox"/> Y3G2
<input checked="" type="checkbox"/> Y310	

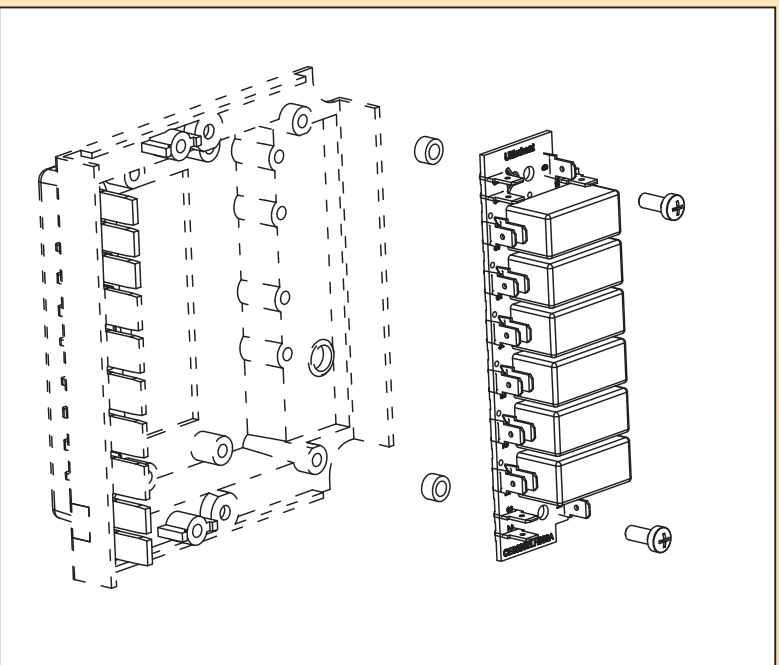
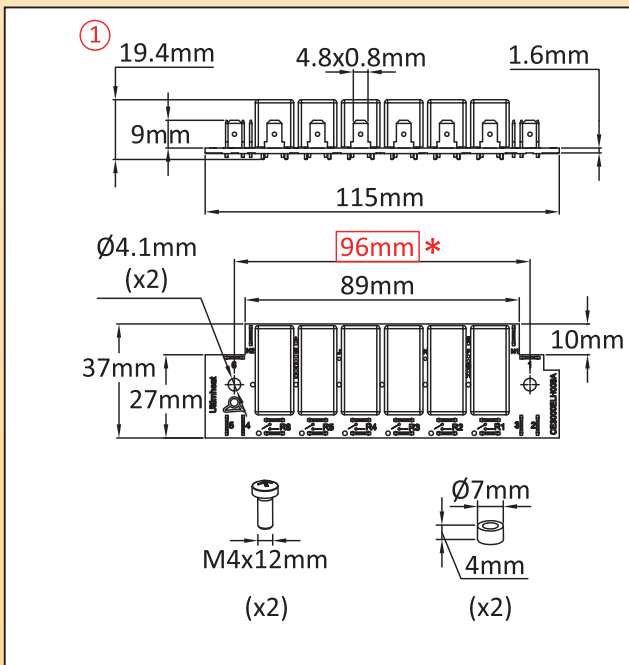
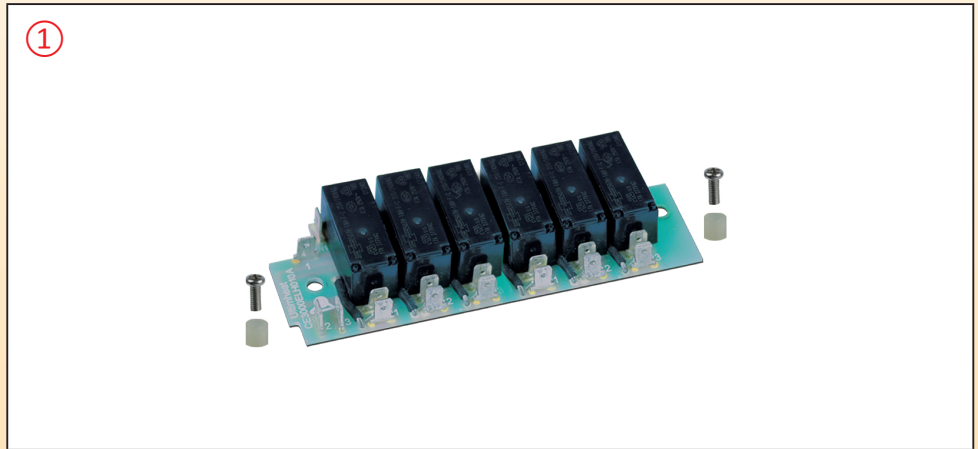

### Main references

Quantity of relays	Independent relays	Coupled relays
4	6YREC230416SF000	6YREC230416PF000
5	6YREC230516SF000	6YREC230516PF000
6	6YREC230616SF000	6YREC230616PF000
2×3	-----	6YREC230616DF000

### Links

	Page (.pdf)
	Drawing 2D (.dwg)
	Drawing 3D (.stp)

The relay coil is 230V 50 Hz. 24V on request. Maximum load 16A resistive, 100000 cycles. Maximum potential difference between contacts: 250V AC

Red dimensions inside rectangular frames on drawings are used for assembly on enclosures or on fittings.

Because of permanent improvement of our products, drawings, descriptions, features used on these data sheets are for guidance only and can be modified without prior advice

# Internal rotation stamped rings, for immersion heaters fittings

Minimum Size	Maximum Size	Material	Type	Model
1"	M77 × 2	Stainless steel AISI 304	Rotation flanges for fittings	<b>66XF</b>

Compatible with:	
☒ 66R2	☒ 66RJ
☒ 66R3	☒ 66RK
☒ 66R4	☒ 66RO
☒ 66R5	☒ 66RP
☒ 66R6	☒ 66RQ
☒ 66R7	☒ 66RR
☒ 66R8	☒ 66RU
☒ 66R9	☒ 66RV
☒ 66RE	☒ 66RW
☒ 66RF	☒ 66RY

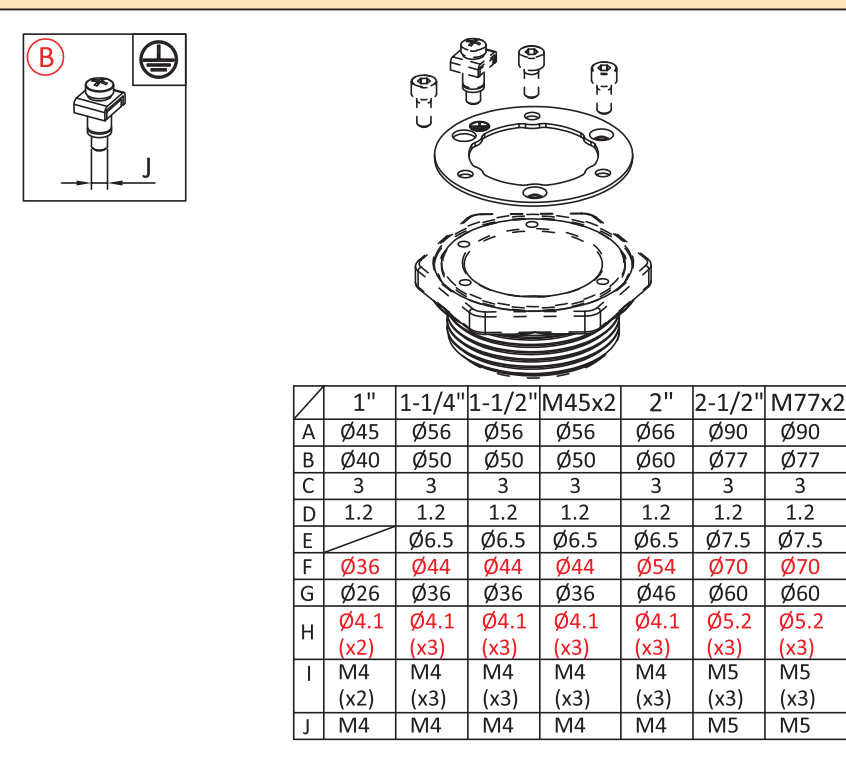
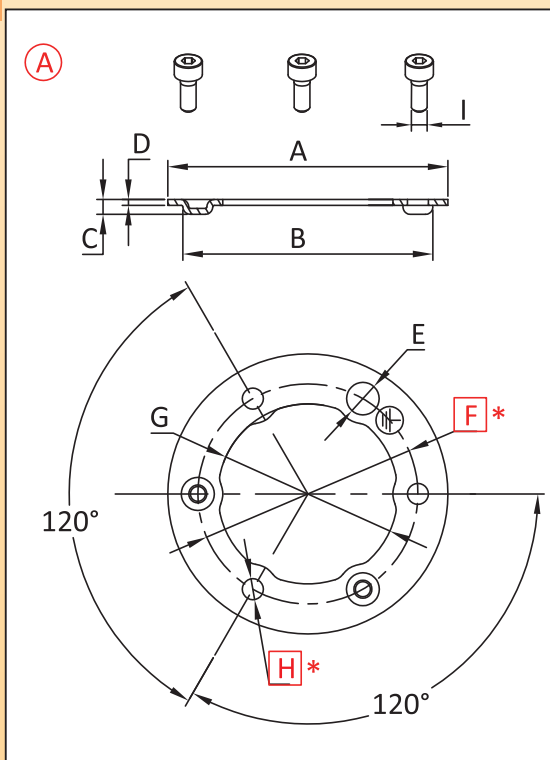
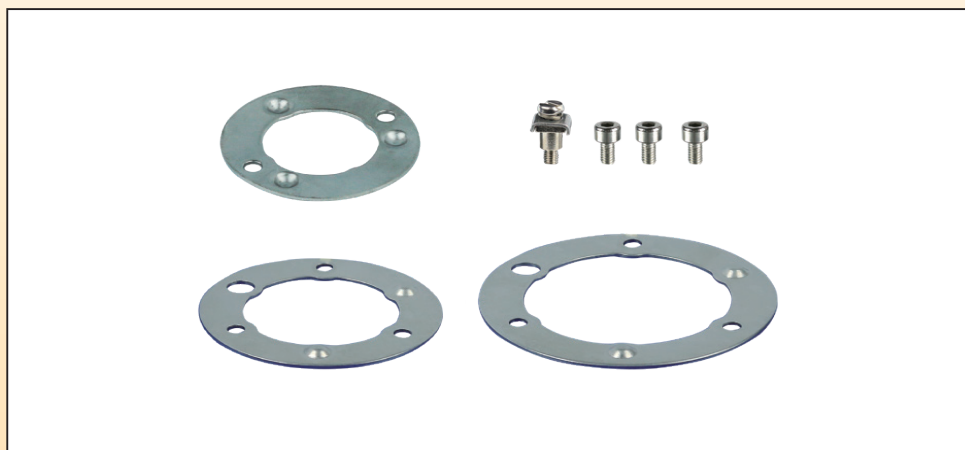

### Main references

Dimension	(A)	(A) + (B)
1"	66XF236I120NU000	66XF236I120NU100
1-1/4" 1-1/2" M45x2	66XF344I120NU000	66XF344I120NU300
2"	66XF354I120NU000	66XF354I120NU300
2-1/2" M77x2	66XF370I120NU000	66XF370I120NU500

### Links

Page  
(.pdf)

Drawing 2D  
(.dwg)

Drawing 3D  
(.stp)

Red dimensions inside rectangular frames on drawings are used for assembly on enclosures or on fittings.

# Threaded internal rotation rings, tightening by 3 screws

Minimum Size	Maximum Size	Material	Type	Model
1"	M77 × 2	Nickel plated screws	Threaded internal rotation rings	<b>66XN</b>

## Compatible with:

<input checked="" type="checkbox"/> Y303	<input checked="" type="checkbox"/> Y3S3
<input checked="" type="checkbox"/> Y304	<input checked="" type="checkbox"/> Y3S5
<input checked="" type="checkbox"/> Y305	<input checked="" type="checkbox"/> Y3S7
<input checked="" type="checkbox"/> Y306	<input checked="" type="checkbox"/> Y3SA
<input checked="" type="checkbox"/> Y307	<input checked="" type="checkbox"/> Y3P1
<input checked="" type="checkbox"/> Y3C4	<input checked="" type="checkbox"/> Y3P3
<input checked="" type="checkbox"/> Y3L1	<input checked="" type="checkbox"/> Y3P4
<input checked="" type="checkbox"/> Y3L3	<input checked="" type="checkbox"/> Y3P5
<input checked="" type="checkbox"/> Y3M1	<input checked="" type="checkbox"/> Y3P6

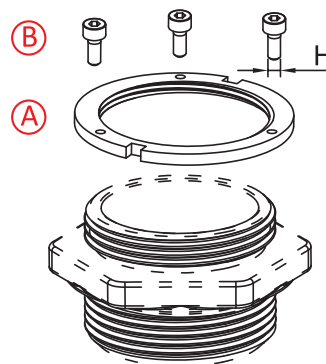
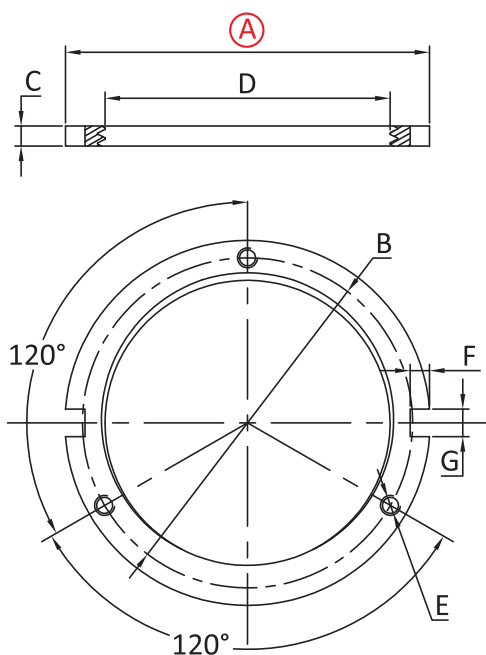

	1"	1-1/4"	1-1/2"	M45x2	2"	2-1/2"	M77x2
A	Ø47.5	Ø56	Ø62	Ø59	Ø74	Ø92	Ø94
B	Ø40.5	Ø49	Ø55	Ø52	Ø67	Ø84	Ø86
C	4	4	4	4	4	4	4
D	1"	1-1/4"	1-1/2"	M45x2	2"	2-1/2"	M77x2
E	M4(x3)	M4(x3)	M4(x3)	M4(x3)	M4(x3)	M5(x3)	M5(x3)
F	4	4	4	4	4	4	4
G	5.5	5.5	5.5	5.5	5.5	5.5	5.5
H	M4x8	M4x8	M4x8	M4x8	M4x8	M5x8	M5x8

## Main references

Dimension	Reference (A)	Reference (A+B)
1"	66XN000A40T10000	66XN000A40T10200
1-1/4"	66XN000A40T14000	66XN000A40T14200
1-1/2"	66XN000A40T12000	66XN000A40T12200
M45x2	66XN000A40T45000	66XN000A40T45200
2"	66XN000A40T20000	66XN000A40T20200
2-1/2"	66XN000A40T21000	66XN000A40T21200
M77x2	66XN000A40T77000	66XN000A40T77200

## Links



Page  
(.pdf)



Drawing 2D  
(.dwg)



Drawing 3D  
(.stp)

Red dimensions inside rectangular frames on drawings are used for assembly on enclosures or on fittings.

# External rotation rings, for immersion heater fittings. Allow to adjust angular position of immersion heater enclosure after assembly on tank, without need to open it

Minimum Size	Maximum Size	Material	Type	Model
0	M77 × 2	Aluminum	External rotation ring for fittings assembly	<b>66XE</b>

**Compatible with:**

- Y3G1
- Y3G2
- Y309

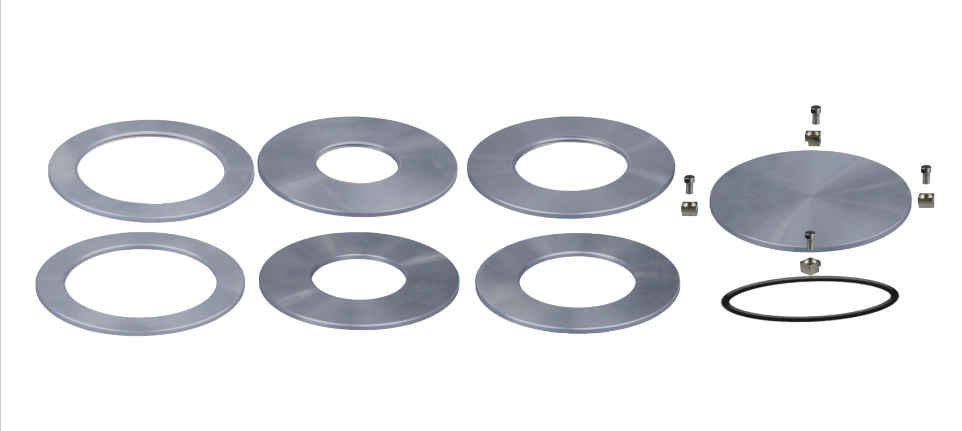

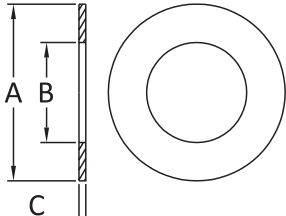
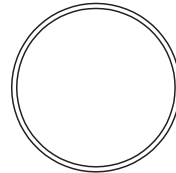
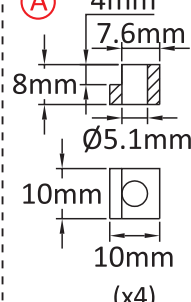
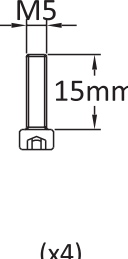
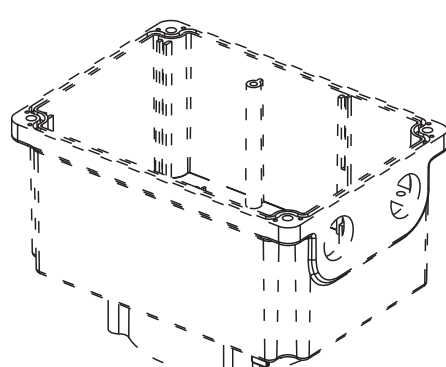
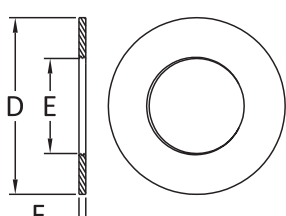
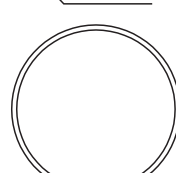
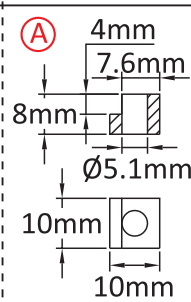
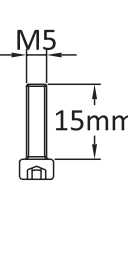
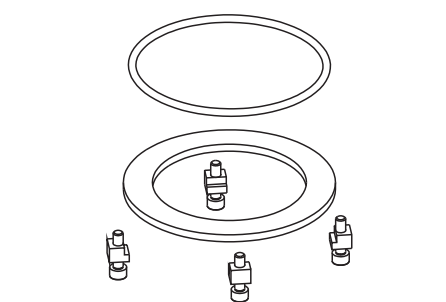
<p>①</p> <table border="1"> <tr> <td>0</td> <td>Ø45</td> <td>Ø50</td> <td>Ø60</td> <td>Ø77</td> </tr> <tr> <td>A Ø106</td> <td>Ø106</td> <td>Ø106</td> <td>Ø106</td> <td>Ø106</td> </tr> <tr> <td>B 0</td> <td>Ø45</td> <td>Ø50</td> <td>Ø60</td> <td>Ø77</td> </tr> <tr> <td>C 4</td> <td>4</td> <td>4</td> <td>4</td> <td>4</td> </tr> </table> 	0	Ø45	Ø50	Ø60	Ø77	A Ø106	Ø106	Ø106	Ø106	Ø106	B 0	Ø45	Ø50	Ø60	Ø77	C 4	4	4	4	4	<p>Ø101mm</p> <p>Ø3mm</p> 	<p>④</p> <p>4mm</p> <p>7.6mm</p> <p>8mm</p> <p>Ø5.1mm</p> <p>10mm</p> <p>10mm</p> <p>(x4)</p> 	<p>M5</p> <p>15mm</p> <p>(x4)</p> 	
	0	Ø45	Ø50	Ø60	Ø77																			
A Ø106	Ø106	Ø106	Ø106	Ø106																				
B 0	Ø45	Ø50	Ø60	Ø77																				
C 4	4	4	4	4																				
<p>②</p> <table border="1"> <tr> <td>M45x2</td> <td>M77x2</td> <td>1-1/2"</td> <td>2"</td> <td>2-1/2"</td> </tr> <tr> <td>D Ø106</td> <td>Ø106</td> <td>Ø106</td> <td>Ø106</td> <td>Ø106</td> </tr> <tr> <td>E M45x2</td> <td>M77x2</td> <td>1-1/2"</td> <td>2"</td> <td>2-1/2"</td> </tr> <tr> <td>F 4</td> <td>4</td> <td>4</td> <td>4</td> <td>4</td> </tr> </table> 	M45x2	M77x2	1-1/2"	2"	2-1/2"	D Ø106	Ø106	Ø106	Ø106	Ø106	E M45x2	M77x2	1-1/2"	2"	2-1/2"	F 4	4	4	4	4	<p>Ø101mm</p> <p>Ø3mm</p> 	<p>④</p> <p>4mm</p> <p>7.6mm</p> <p>8mm</p> <p>Ø5.1mm</p> <p>10mm</p> <p>10mm</p> <p>(x4)</p> 	<p>M5</p> <p>15mm</p> <p>(x4)</p> 	
	M45x2	M77x2	1-1/2"	2"	2-1/2"																			
D Ø106	Ø106	Ø106	Ø106	Ø106																				
E M45x2	M77x2	1-1/2"	2"	2-1/2"																				
F 4	4	4	4	4																				

## Main references

## Links

Drilled hole ①		Drilled hole ① + ④		Drilled hole ②		Drilled hole ② + ④	
Drill	References	References	Thread	References	References	References	References
0	66XE106L40000000	66XE106L400006RS	M45×2	66XE106L40T45000	66XE106L40T456RS		
45mm	66XE106L40D45000	66XE106L40D456RS	M77×2	66XE106L40T77000	66XE106L40T776RS		
50mm	66XE106L40D50000	66XE106L40D506RS	1-1/2"	66XE106L40T12000	66XE106L40T126RS		
60mm	66XE106L40D60000	66XE106L40D606RS	2"	66XE106L40T20000	66XE106L40T206RS		
77mm	66XE106L40D77000	66XE106L40D776RS	2-1/2"	66XE106L40T21000	66XE106L40T216RS		



Page  
(.pdf)



Drawing 2D  
(.dwg)



Drawing 3D  
(.stp)

Other drilled or tapped holes diameters on request

Red dimensions inside rectangular frames are used for assembly on enclosures or on fittings.



# Internal mounting boards for enclosures with controls

Mounting style	Material	Type	Model
<b>Assembly on enclosure with 2 mounting holes at 108 mm distance</b>	<b>PA66 / aluminum</b>	<b>Flat Internal board</b>	<b>6YFB</b>

Compatible with:	
<input checked="" type="checkbox"/> Y3N1	<input checked="" type="checkbox"/> Y3G1
<input checked="" type="checkbox"/> Y3N2	<input checked="" type="checkbox"/> Y3G2
<input checked="" type="checkbox"/> Y3N3	<input checked="" type="checkbox"/> Y309
<input checked="" type="checkbox"/> Y3N4	<input checked="" type="checkbox"/> Y3J1
<input checked="" type="checkbox"/> Y3H1	<input checked="" type="checkbox"/> Y3J2
<input checked="" type="checkbox"/> Y3H2	<input checked="" type="checkbox"/> Y310
<input checked="" type="checkbox"/> Y3H3	

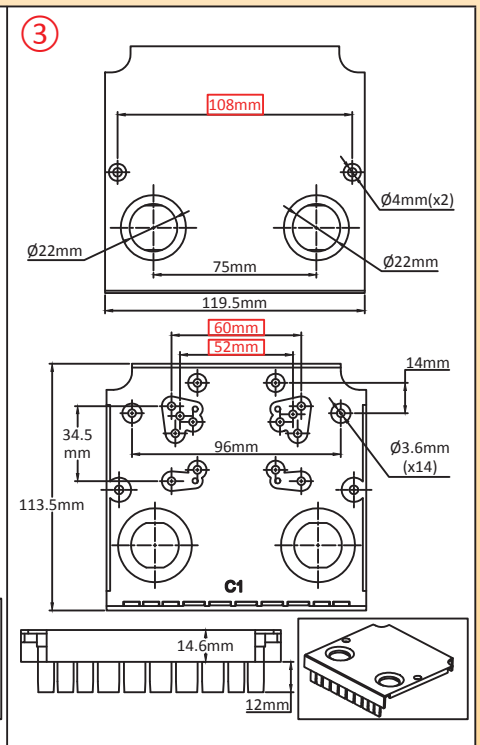
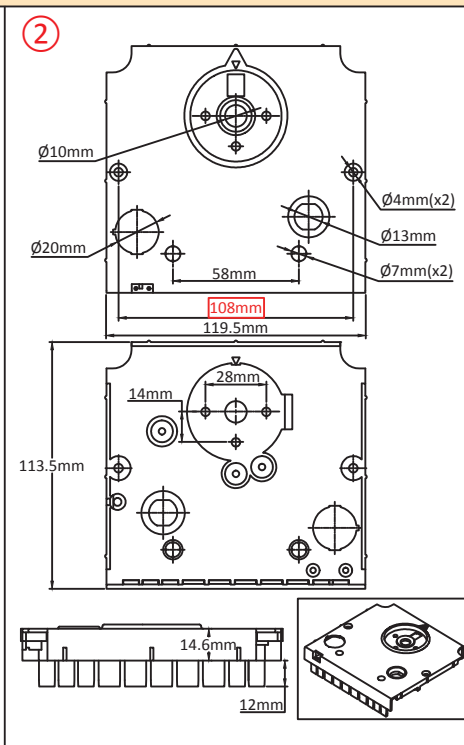
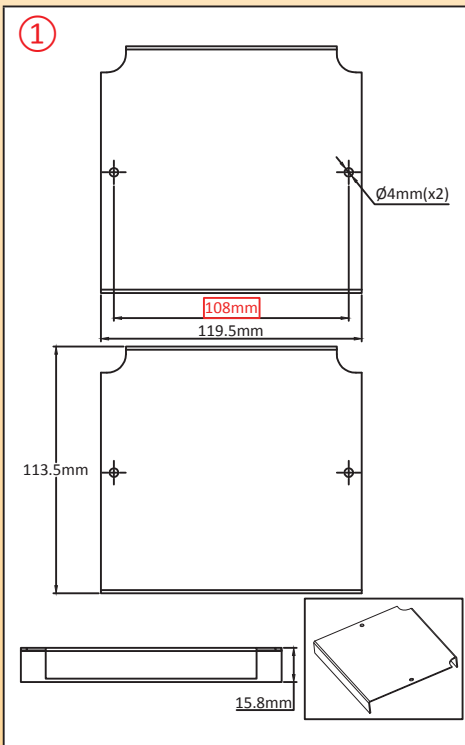
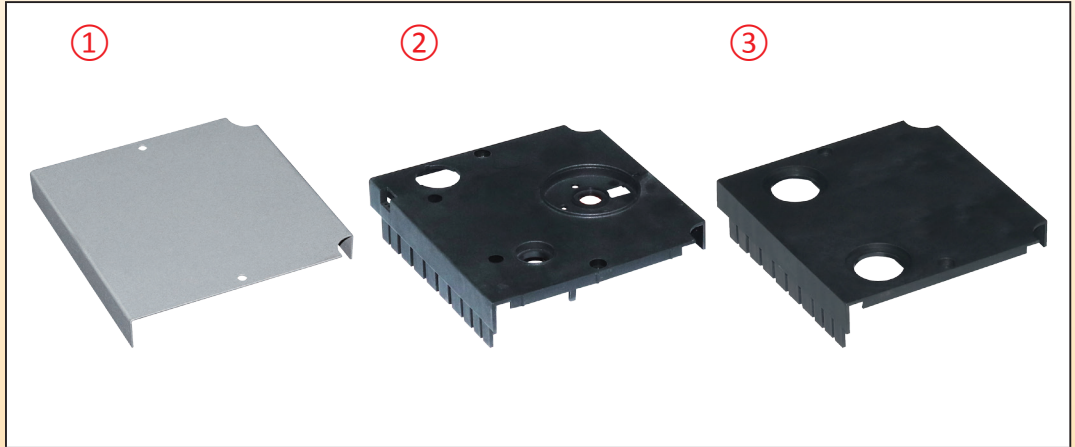

Aluminum board. For customer drilling and mounting.

PA66, for thermostat, with hole for fusible holder, on-off switch and 2 pilot lights. No studs for relays.

PA66, 2 holes for 22mm pilot lights, one hole for fusible holder. Studs for relays.

### Main references

①	6YFBCALF01
②	6YFBCPAF01
③	6YFBCPAF02

### Links

 Page (.pdf)	 Drawing 2D (.dwg)	 Drawing 3D (.stp)
--------------------	-----------------------------	-----------------------------

Because of permanent improvement of our products, drawings, descriptions, features used on these data sheets are for guidance only and can be modified without prior advice.

These mounting boards are provided with removable caps for non-used holes. Ask our engineering department for controls you would like to put on them.

Red dimensions inside rectangular frames on drawings are used for assembly on enclosures or on fittings.

## Internal mounting boards for enclosures with controls

Mounting style	Material	Type	Model
Assembly on enclosure with 2 mounting holes at 108 mm distance	PA66	5 mm elevated Internal board	<b>6YFC</b>

### Compatible with:

- |  |  |
|--|--|
| <input checked="" type="checkbox"/> Y3N1 | <input checked="" type="checkbox"/> Y3G1 |
| <input checked="" type="checkbox"/> Y3N2 | <input checked="" type="checkbox"/> Y3G2 |
| <input checked="" type="checkbox"/> Y3N3 | <input checked="" type="checkbox"/> Y309 |
| <input checked="" type="checkbox"/> Y3N4 | <input checked="" type="checkbox"/> Y3J1 |
| <input checked="" type="checkbox"/> Y3H2 | <input checked="" type="checkbox"/> Y3J2 |
| <input checked="" type="checkbox"/> Y3H3 | <input checked="" type="checkbox"/> Y310 |

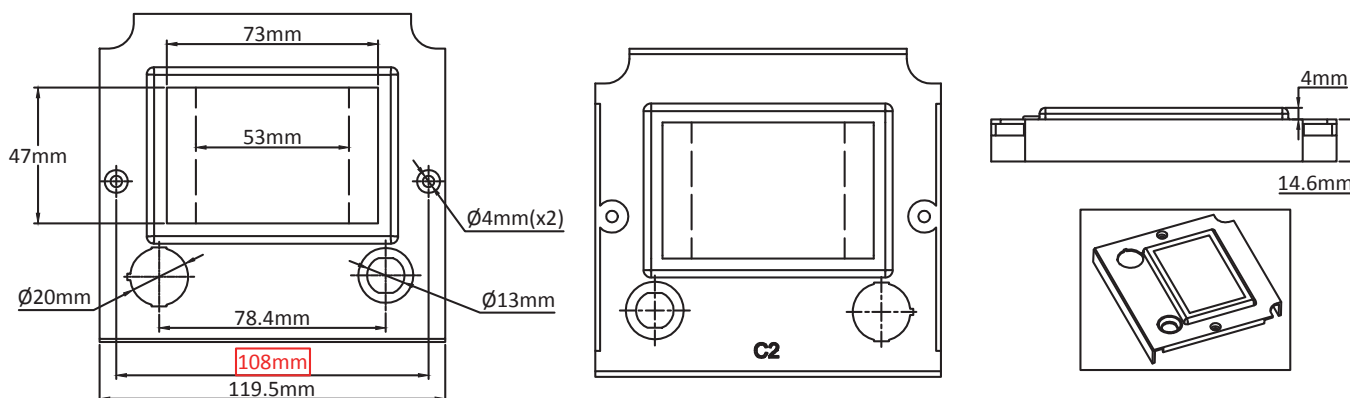
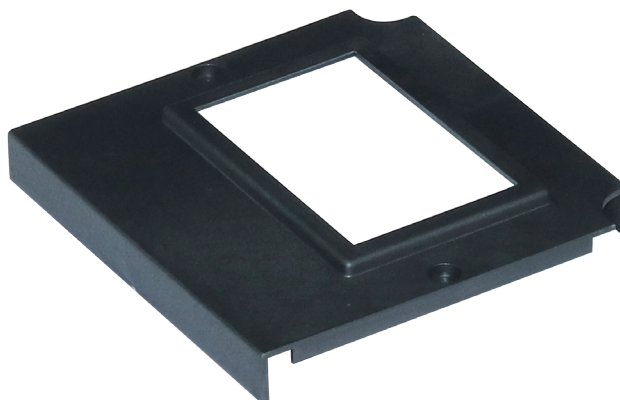

PA66, one rectangular hole 73x47mm. With two mobile caps for reduce and move hole to 53x47mm. Can be used for 2DNA and ground fault detection contactor. Hole for on-off switch and hole for fusible holder. No studs for relays or contactors. When used with 2DNA, fits flat cover enclosures.

### Main reference

6YFCCPAG01

### Links



Page  
(.pdf)



Drawing  
2D  
(.dwg)



Drawing  
3D  
(.stp)

These mounting boards are provided with removable caps for non-used holes. Ask our engineering department for controls you would like to put on them.

Red dimensions inside rectangular frames are used for assembly on enclosures or on fittings.

# Internal mounting boards for enclosures with controls

Mounting style	Material	Type	Model
<b>Assembly on enclosure with 2 mounting holes at 108 mm distance</b>	<b>PA66</b>	<b>15.5 mm elevated Internal board</b>	<b>6YFD</b>

Compatible with:	
<input checked="" type="checkbox"/> Y3N2	<input checked="" type="checkbox"/> Y3G2
<input checked="" type="checkbox"/> Y3N3	<input checked="" type="checkbox"/> Y309
<input checked="" type="checkbox"/> Y3N4	<input checked="" type="checkbox"/> Y3J2
<input checked="" type="checkbox"/> Y3H2	<input checked="" type="checkbox"/> Y310
<input checked="" type="checkbox"/> Y3H3	

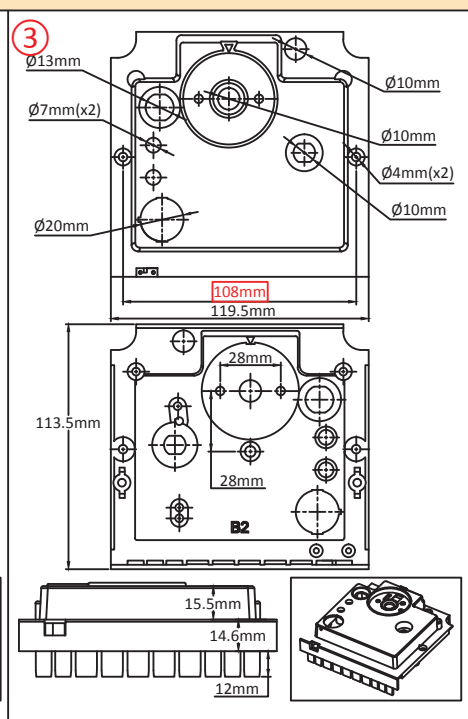
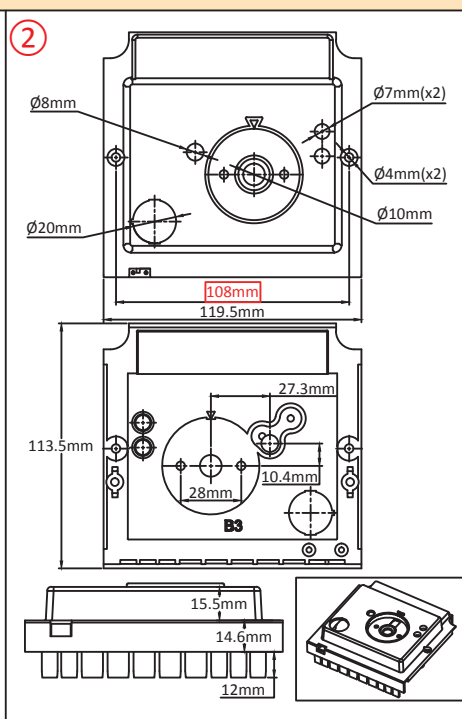
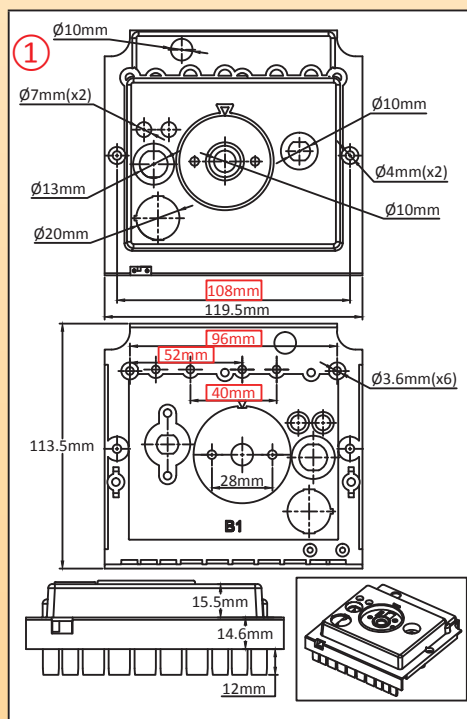
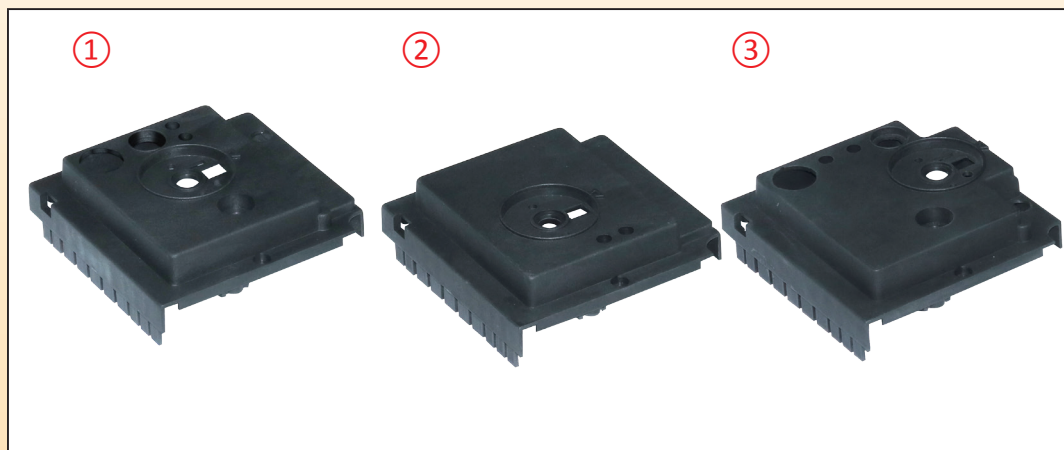

PA66, hole for single pole or 3 pole bulb and capillary thermostat. Hole for fuse holder. Hole for on-Off switch. 2 holes for manual reset. 2 holes for pilot lights. Studs for relays boards 3 and 6 relays

PA66, hole for 3 pole bulb and capillary thermostat and control. Manual reset 3 pole combination thermostat. No hole for fuse holder. No hole for on-Off switch. 2 holes for manual reset (must be drilled). 2 holes for pilot lights. No studs for relays boards.

PA66, hole for single pole commercial bulb and capillary thermostat (type K). Hole for fuse holder. Hole for On-Off switch. 3 holes for manual reset. 2 holes for pilot lights. Studs for relays boards 3 and 6 relays, holes for contactor

### Main references

<b>①</b>	6YFDCPAB06
<b>②</b>	6YFDCPAB08
<b>③</b>	6YFDCPAB07

### Links

 <p>Page (.pdf)</p>	 <p>Drawing 2D (.dwg)</p>	 <p>Drawing 3D (.stp)</p>	
--	---	--	--

These mounting boards are provided with removable caps for non-used holes. Ask our engineering department for controls you would like to put on them.

Red dimensions inside rectangular frames are used for assembly on enclosures or on fittings.

# Internal mounting boards for enclosures with controls

Mounting style	Material	Type	Model
<b>Assembly on enclosure with 2 mounting holes at 108 mm distance</b>	<b>PA66</b>	<b>19 mm elevated Internal board</b>	<b>6YFE</b>

Compatible with:	
<input checked="" type="checkbox"/> Y3N2	<input checked="" type="checkbox"/> Y3G2
<input checked="" type="checkbox"/> Y3N3	<input checked="" type="checkbox"/> Y309
<input checked="" type="checkbox"/> Y3N4	<input checked="" type="checkbox"/> Y3J2
<input checked="" type="checkbox"/> Y3H2	<input checked="" type="checkbox"/> Y310
<input checked="" type="checkbox"/> Y3H3	

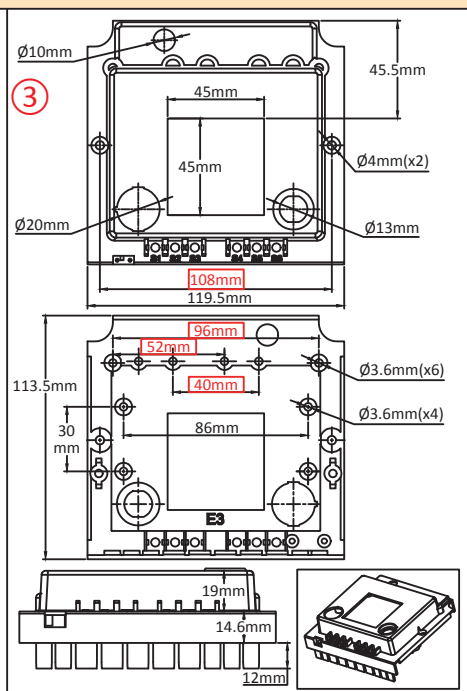
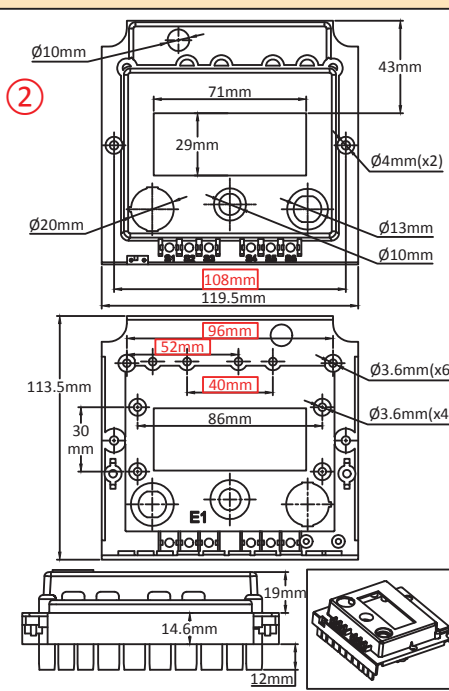
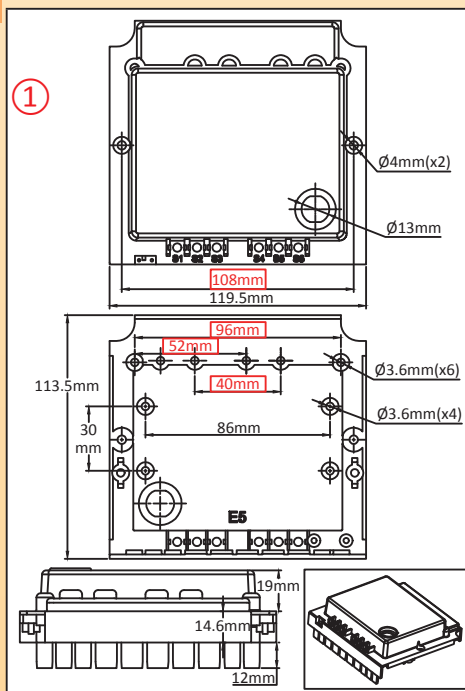
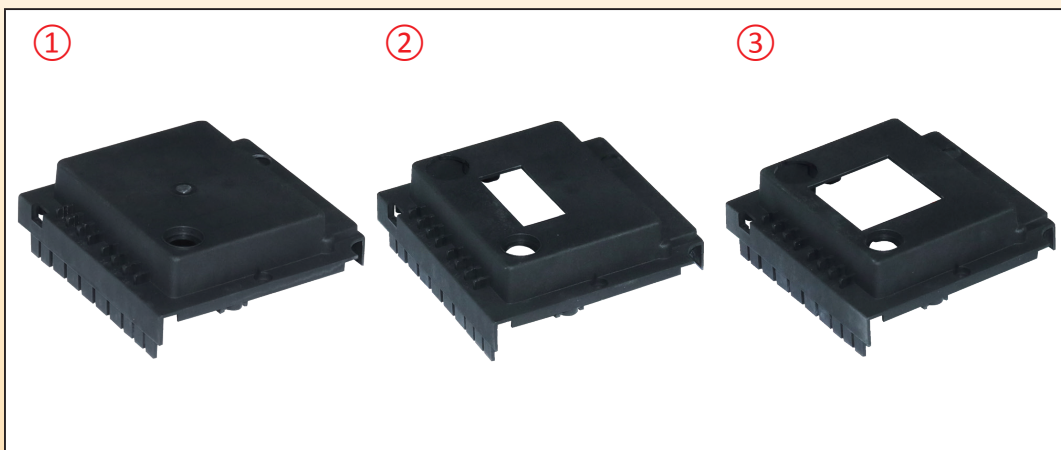

PA66, for customer drilling. Hole for fuse holder, hole for manual reset. Holes for 6 ways low voltage electronic connection block. Studs for relays boards 3 and 6 relays. 4 studs for customer electronic board.

PA66, hole 71x29mm for 78x35 electronic controller. Hole for fuse holder, hole for manual reset. Holes for 6 ways low voltage electronic connection block. Studs for relays boards 3 and 6 relays. 4 studs for customer electronic board.

PA66, hole 45x45mm for 48x48 electronic controller or two 45x22mm controllers. Hole for fuse holder, hole for manual reset. Holes for 6 ways low voltage electronic connection block. Studs for relays boards 3 and 6 relays. 4 studs for customer electronic board.

### Main references

①	6YFECBAB01
②	6YFECBAB03
③	6YFBCBAB04

### Links

Page (.pdf)	Drawing 2D (.dwg)	Drawing 3D (.stp)

These mounting boards are provided with removable caps for non-used holes. Ask our engineering department for controls you would like to put on them.

Red dimensions inside rectangular frames are used for assembly on enclosures or on fittings.

# Alphabetical list of subfamilies references



Sub families	Page No.	Sub families	Page No.	Sub families	Page No.
66JE	196	66UT	209	Y3E6	13, 14, 135
66JF	192	66XE	222	Y3E7	13, 14, 136
66JL	193	66XF	220	Y3E8	13, 14, 137
66JP	191	66YQ	214	Y3F1	6, 9, 121
66JR	194, 195	66YS	212	Y3F2	6, 10, 122
66KC	198	66YU	213	Y3F3	6, 10, 123
66KD	200	66Z1	216	Y3G1	15, 19, 159, 160
66KP	199	66Z2	216	Y3G2	15, 19, 161, 162
66NI	197	67XN	221	Y3H1	15, 17, 156
66NK	197	6YFB	223	Y3H2	15, 17, 157
66NL	197	6YFC	224	Y3H3	15, 17, 158
66NS	215	6YFD	225	Y3J1	15, 20, 165, 166
66NT	197	6YFE	226	Y3J2	15, 20, 167, 168
66Q1	201	6YRC	218	Y3K1	1, 2, 85
66Q2	202	6YRE	219	Y3K2	1, 2, 86
66Q3	202	6YRM	217	Y3L1	1, 2, 87
66Q4	203	BEJ	205	Y3L2	1, 2, 88
66R2	177	BEL	205	Y3L3	1, 2, 89
66R3	178	BEN	204	Y3L4	1, 3, 90
66R4	179	BEO	204	Y3M1	6, 11, 126, 127
66R5	180	BEP	206	Y3N1	6, 11, 128
66R6	177	BEQ	206	Y3N2	6, 11, 129
66R7	178	BER	206	Y3N3	6, 12, 130
66R8	179	BES	207	Y3N4	6, 12, 131
66R9	180	BET	207	Y3P1	15, 16, 147, 148
66RB	183	Y301	6, 7, 111	Y3P3	15, 16, 149, 150
66RC	184	Y302	6, 7, 112	Y3P4	15, 17, 151
66RD	185	Y303	15, 141, 142	Y3P5	15, 17, 152, 153
66RE	187	Y304	15, 16, 143, 144	Y3P6	15, 17, 154, 155
66RF	186	Y305	15, 16, 145, 146	Y3S3	1, 3, 91
66RG	188	Y306	6, 9, 118, 119	Y3S4	1, 3, 92
66RJ	173	Y307	6, 10, 124, 125	Y3S5	1, 3, 93
66RK	174	Y309	15, 19, 163, 164	Y3S6	1, 3, 94
66RO	175	Y310	15, 20, 169, 170	Y3S7	1, 4, 100
66RP	175	Y3A1	6, 107	Y3S8	1, 5, 101
66RQ	176	Y3A2	6, 108	Y3S9	1, 5, 102
66RR	176	Y3A3	6, 7, 109	Y3SA	1, 3, 95
66RU	173	Y3A4	6, 7, 110	Y3SB	1, 4, 96
66RV	174	Y3B1	6, 8, 116	Y3SC	1, 4, 97
66RW	181	Y3B2	6, 8, 117	Y3T8	1, 5, 103
66RY	182	Y3C1	6, 7, 113	Y3TA	1, 5, 104
66TNL4	210	Y3C2	6, 8, 114	Y3TB	1, 4, 98
66TNW3	211	Y3C3	6, 8, 115	Y3TC	1, 4, 99
66TNW8	208	Y3C4	6, 9, 120		
66TTL4	210	Y3C6	13, 132		
66TTW3	211	Y3C7	13, 133		
66TTW8	208	Y3C8	13, 14, 134		

Because of permanent improvement of our products, drawings, descriptions, features used on these data sheets are for guidance only and can be modified without prior advice

# Alphabetical list of products references used in this catalogue

References	Page	References	Page	References	Page	References	Page	References	Page	References	Page
66JEN50040H60000	196	66Q1S02235000000	201	66RQA7T****0000	176	66XE106L40T12000	222	Y30300001T000007	141	Y303500D12000007	142
66JEN80040H92000	196	66Q2S03235000000	201	66RQA7T****0005	176	66XE106L40T126RS	222	Y30300001T00000G	141	Y303500D1200000G	142
66JES50040H60000	196	66Q2PM1M25000000	202	66RQMDT****0000	176	66XE106L40T20000	222	Y30300001T500007	141	Y303500D12500007	142
66JES80040H92000	196	66Q3PM3M25000000	202	66RQMDT****0005	176	66XE106L40T206RS	222	Y30300001T50000G	141	Y303500D1250000G	142
66JFC32022500000	192	66Q3PM3M25000000	202	66RQMDT****0000	176	66XE106L40T21000	222	Y3030000A00000007	141	Y303500D1T000007	142
66JFC40022620000	192	66Q4SM31000000000	203	66RQMGV****0005	176	66XE106L40T216RS	222	Y3030000A0000000G	141	Y303500D1T00000G	142
66JFC44022620000	192	66R2A3T****0000	177	66RRA3T****0000	176	66XE106L40T45000	222	Y303000A12000007	141	Y303500D1T500007	142
66JFC58022760000	192	66R2A3T****0005	177	66RRA3T****0005	176	66XF344120N1U000	220	Y303000A1250000G	141	Y303500F1250000G	142
66JFC74022950000	192	66R2MDT****0000	177	66RRA7T****0000	176	66XE106L40T7000	222	Y303000A12500007	141	Y303500F00000007	142
66JLN32040500000	193	66R2MDT****0005	177	66RRA7T****0005	176	66XE106L40T776RS	222	Y303000A1250000G	141	Y303500F0000000G	142
66JLN58040500000	193	66R3A3T****0000	178	66RRMDT****0000	176	66XF2361120NU000	220	Y303000A1T000007	141	Y303500F12000007	142
66JLN70040600000	193	66R3A3T****0005	178	66RRMDT****0005	176	66XF2361120NU100	220	Y303000A1T00000G	141	Y303500F1200000G	142
66JLN90040770000	193	66R3MDT****0000	178	66RRMGT****0000	176	66XF3441120NU000	220	Y303000A1T500007	141	Y303500F12500007	142
66JLS32040500000	193	66R3MDT****0005	178	66RRMGT****0005	176	66XF3441120NU300	220	Y303000A1T50000G	141	Y303500F1250000G	142
66JLS58040500000	193	66R4A3T****0000	179	66RUA3T****0000	173	66XF3541120NU000	220	Y303000D00000007	141	Y303500F1T000007	142
66JLS70040600000	193	66R4A3T****0005	179	66RUA3T****0005	173	66XF3541120NU300	220	Y303000D0000000G	141	Y303500F1T00000G	142
66JLS90040770000	193	66R4MDT****0000	179	66RUA7T****0000	173	66XF3701120NU000	220	Y303000D12000007	141	Y303500F1T500007	142
66JLS32040500000	193	66R4MDT****0005	179	66RUA7T****0005	173	66XF3701120NU500	220	Y303000D1200000G	141	Y303500F1T50000G	142
66JLV58040500000	193	66R5A3T****0000	180	66RUMDT****0000	173	66XN000A40T10000	221	Y303000D12500007	141	Y303BA200000007	142
66JLV70040600000	193	66R5A3T****0005	180	66RUMDT****0005	173	66XN000A40T10000G	221	Y303000D1250000G	141	Y303BA20000000G	142
66JLV90040770000	193	66R5MDT****0000	180	66RUMGT****0000	173	66XN000A40T12000	221	Y303000D1T000007	141	Y303BA2012000007	142
66JPN32020500000	191	66R5MDT****0005	180	66RUMGT****0005	173	66XN000A40T12200	221	Y303000D1T00000G	141	Y303BA201200000G	142
66JPN40020620000	191	66R6A3T****0000	177	66RVA3T****0000	174	66XN000A40T14000	221	Y303000D1T500007	141	Y303BA2012500007	142
66JPN40020620000	191	66R6A3T****0005	177	66RVA3T****0005	174	66XN000A40T14000G	221	Y303000D1T50000G	141	Y303BA201250000G	142
66JPN58020760000	191	66R6MDT****0000	177	66RVA7T****0000	174	66XN000A40T12000	221	Y303000F00000007	141	Y303BA201T000007	142
66JPN74020950000	191	66R6MDT****0005	177	66RVA7T****0005	174	66XN000A40T20200	221	Y303000F0000000G	141	Y303BA201T00000G	142
66JPP32020500000	191	66R7A3T****0000	178	66RVMDT****0000	174	66XN000A40T21000	221	Y303000F12000007	141	Y303BA201T500007	142
66JPP40020620000	191	66R7A3T****0005	178	66RVMDT****0005	174	66XN000A40T21200	221	Y303000F1200000G	141	Y303BA201T50000G	142
66JPP44020620000	191	66R7MDT****0000	178	66RVMGT****0000	174	66XN000A40T45000	221	Y303000F12500007	141	Y303BA2A00000007	142
66JPP58020760000	191	66R7MDT****0005	178	66RVMGT****0005	174	66XN000A40T45200	221	Y303000F1250000G	141	Y303BA2A0000000G	142
66JPP74020950000	191	66R8A3T****0000	179	66RWA5T026000000	181	66XN000A40T77000	221	Y303000F1T000007	141	Y303BA2A12000007	142
66JPS32020500000	191	66R8A3T****0005	179	66RWA5T026000006	181	66XN000A40T77200	221	Y303000F1T00000G	141	Y303BA2A1200000G	142
66JPS40020620000	191	66R8MDT****0000	179	66RWA5T026000008	181	66YQC0411710000	214	Y303000F1T500007	141	Y303BA2A12500007	142
66JPS40020620000	191	66R8MDT****0005	179	66RWA5T026000008	181	66YQC0411710000G	214	Y303000F1T50000G	141	Y303BA2A1250000G	142
66JPS58020760000	191	66R9A3T****0000	180	66RYA5T026000000	182	66YQC03411710000	214	Y303450000000007	141	Y303BA2A1T000007	142
66JPS74020950000	191	66R9A3T****0005	180	66RYA5T026000006	182	66YQC3411710000	214	Y30345000000000G	141	Y303BA2A1T00000G	142
66JRN55020510000	194	66R9MDT****0000	180	66RYA5T026000008	182	66YSC112122****	212	Y303450012000007	142	Y303BA2A1T500007	142
66JRN65020610000	194	66R9MDT****0005	180	66RYA5T026000008	182	66YSC112122****	212	Y30345001200000G	142	Y303BA2A1T50000G	142
66JRN82020780000	194	66RBA1T000000000	183	66TOL42600000000	210	66YSC211212****	212	Y303450012500007	142	Y303BA2D00000007	142
66JRN87030810000	195	66RBA2T000000000	183	66TOL42600000005	210	66YSC211212****	212	Y30345001250000G	142	Y303BA2D0000000G	142
66JRS55020510000	194	66RBA3T000000000	183	66TNL42645072500	210	66YSM452122****	212	Y30345001T000007	142	Y303BA2D12000007	142
66JRS65020610000	194	66RBA5T000000000	183	66TNL42660072500	210	66YSM452122****	212	Y30345001T00000G	142	Y303BA2D1200000G	142
66JRS82020780000	194	66RBA7T000000000	183	66TNL426800072500	210	66YSM772122****	212	Y30345001T500007	142	Y303BA2D12500007	142
66JRS87030810000	195	66RBM0T000000000	183	66TNW300230A100K	211	66YSM772122****	212	Y30345001T50000G	142	Y303BA2D1250000G	142
66KD10000000000	200	66RBMGT000000000	183	66TNW300230A1B0K	211	66YUC112122****	213	Y3034500A00000007	141	Y303BA2D1T000007	142
66KD21000000000	200	66RCA3T000000000	184	66TNW300300A100K	211	66YUC112122****	213	Y3034500A0000000G	141	Y303BA2D1T00000G	142
66KD31000000000	200	66RCA5000000000	184	66TNW300300A1B0K	211	66YUC212122****	213	Y3034500A12000007	142	Y303BA2D1T500007	142
66KD41000000000	200	66RCA7000000000	184	66TNW300405A100K	211	66YUC212122****	213	Y3034500A1200000G	142	Y303BA2D1T50000G	142
66KD51000000000	200	66RCMD0000000000	184	66TNW300405A1B0K	211	66YUM452122****	213	Y3034500A12500007	142	Y303BA2F00000007	142
66KD61000000000	200	66RCMG0000000000	184	66TNW300600A100K	211	66YUM452122****	213	Y3034500A1250000G	142	Y303BA2F0000000G	142
66KE11000000000	198	66RDA1T000000000	185	66TNW300600A1B0K	211	66YUM772122****	213	Y3034500A1T000007	142	Y303BA2F12000007	142
66KE21000000000	198	66RDA2T000000000	185	66TNW800450A550K	208	66YUM772122****	213	Y3034500A1T00000G	142	Y303BA2F1200000G	142
66KG61000000000	199	66REA2T000000000	187	66TNW800600A550K	208	66Z1P60931010265	216	Y3034500A1T500007	142	Y303BA2F12500007	142
66KU11000000000	199	66REA3T000000000	187	66TNW800800A550K	208	66Z2P60952010265	216	Y3034500A1T50000G	142	Y303BA2F1250000G	142
66KU21000000000	199	66REA5T000000000	187	66TTL42645072500	210	6YRCB230216NF000	218	Y3034500D00000007	141	Y303BA2F1T000007	142
66KU31000000000	199	66REA7T000000000	187	66TTL42645072500	210	6YRCB230216PF000	218	Y3034500D0000000G	141	Y303BA2F1T00000G	142
66NIC01230H44000	197	66REM0T000000000	187	66TTL42660072500	210	6YRCB230316NF000	218	Y3034500D12000007	142	Y303BA2F1T500007	142
66NIC03430H44000	197	66REMGT000000000	187	66TTL42680072500	210	6YRCB230316PF000	218	Y3034500D1200000G	142	Y303BA2F1T50000G	142
66NIC10055H44000	197	66RFA1T000000000	186	66TTL42680072500	210	6YRCD230216PF000	218	Y3034500D12500007	142	Y303M4500000007	142
66NIC11280H52000	197	66RGA2T000000000	188	66TTL42680072500	210	6YRCD230216SF000	218	Y3034500D1250000G	142	Y303M450000000G	142
66NIC11465H50000	197	66RGA3T000000000	188	66TTW300230A100S	211	6YRCD230316PF000	218	Y3034500D1T000007	142	Y303M45012000007	142
66NIC20080H65000	197	66RGM0T000000000	188	66TTW300230A1B0S	211	6YRCD230316SF000	218	Y3034500D1T00000G	142	Y303M4501200000G	142
66NIC21280H85000	197	66RJA3T****0000	173	66TTW300300A100S	211	6YRCE230161NF000	218	Y3034500D1T500007	142	Y303M45012500007	142
66NIM45280H52000	197	66RJA3T****0005	173	66TTW300300A1B0S	211	6YRCE230161PF000	218	Y3034500D1T50000G	142	Y303M4501250000G	142
66NIM77280H85000	197	66RJA7T****0000	173	66TTW300450A100S	211	6YRCE230316NF000	218	Y3034500F00000007	141	Y303M4501T000007	142
66NKC01230H44000	197	66RJA7T****0005	173	66TTW300450A1B0S	211	6YRCE230316PF000	218	Y3034500F0000000G	141	Y303M4501T00000G	142
66NKC03430H44000	197	66RJM0T****0000	173	66TTW300600A100S	211	6YRCE230416PF000	219	Y30345012000007	142	Y303M4501T500007	142
66NKC10055H44000	197	66RJM0T****0005	173	66TTW300600A1B0S	211	6YRCE230416SF000	219	Y3034501200000G	142	Y303M4501T50000G	142
66NKC11280H52000	197	66RJMGT****0000	173	66TTW800450A550K	208	6YREC230516PF000	219	Y3034501T500007	142	Y303M45A00000007	142
66NKC11465H50000	197	66RJMGT****0005	173	66TTW800450A550S	208	6YREC230516SF000	219	Y3034501T50000G	142	Y303M45A0000000G	142
66NKC20080H65000	197	66RKA3T****0000	174	66TTW800600A550K	208	6YREC230616DF000	219	Y3034501T000007	142	Y303M45A12000007	142
66NKC21280H85000	197	66RKA3T****0005	174	66TTW800600A550S	208	6YREC230616PF000	219	Y3034501T00000G	142	Y303M45A1200000G	142
66NKM452											

# Alphabetical list of products references used in this catalogue

References	Page	References	Page	References	Page	References	Page	References	Page	References	Page
Y303M45F1T500007	142	Y304500A12500007	144	Y304M45F00000007	144	Y30550001T000007	146	Y305BA2D12000007	146	Y305M45F1T500007	146
Y303M45F1T50000G	142	Y304500A1250000G	144	Y304M45F0000000G	144	Y30550001T00000G	146	Y305BA2D1200000G	146	Y305M45F1T50000G	146
Y304000000000007	143	Y304500A1T000007	144	Y304M45F12000007	144	Y30550001T500007	146	Y305BA2D12500007	146	Y306000000000007	118
Y30400000000000G	143	Y304500A1T00000G	144	Y304M45F1200000G	144	Y30550001T50000G	146	Y305BA2D1250000G	146	Y30600001160000T	118
Y304000012000007	143	Y304500A1T500007	144	Y304M45F12500007	144	Y305500A00000007	146	Y305BA2D1T000007	146	Y30600001200000T	118
Y30400001200000G	143	Y304500A1T50000G	144	Y304M45F1250000G	144	Y305500A0000000G	146	Y305BA2D1T00000G	146	Y30600001200000G	118
Y304000012500007	143	Y304500D00000007	144	Y304M45F1T000007	144	Y305500A12000007	146	Y305BA2D1T500007	146	Y3060000200000T	118
Y30400001250000G	143	Y304500D0000000G	144	Y304M45F1T00000G	144	Y305500A1200000G	146	Y305BA2D1T50000G	146	Y3060000200000G	118
Y30400001T000007	143	Y304500D12000007	144	Y304M45F1T000007	144	Y305500A12500007	146	Y305BA2F00000007	146	Y306000A000000T	118
Y30400001T00000G	143	Y304500D1200000G	144	Y304M45F1T500007	144	Y305500A1250000G	146	Y305BA2F0000000G	146	Y306000A1160000T	118
Y30400001T500007	143	Y304500D12500007	144	Y305000000000007	145	Y305500A1T000007	146	Y305BA2F12000007	146	Y306000A1200000T	118
Y30400001T50000G	143	Y304500D1250000G	144	Y30500000000000G	145	Y305500A1T00000G	146	Y305BA2F1200000G	146	Y306000A2160000T	118
Y304000A00000007	143	Y304500D1T000007	144	Y3050000012000007	145	Y305500A1T500007	146	Y305BA2F12500007	146	Y306000A2200000T	118
Y304000A0000000G	143	Y304500D1T00000G	144	Y305000001200000G	145	Y305500A1T50000G	146	Y305BA2F1250000G	146	Y306000A2200000G	118
Y304000A12000007	143	Y304500D1T500007	144	Y3050000012500007	145	Y305500D00000007	146	Y305BA2F1T000007	146	Y306000D000000T	118
Y304000A1200000G	143	Y304500D1T50000G	144	Y305000001250000G	145	Y305500D0000000G	146	Y305BA2F1T00000G	146	Y306000D000000G	118
Y304000A12500007	143	Y304500F12500007	144	Y305000001T000007	145	Y305500D12000007	146	Y305BA2F1T500007	146	Y306000D1200000T	118
Y304000A1250000G	143	Y304500F1250000G	144	Y305000001T00000G	145	Y305500D1200000G	146	Y305BA2F1T50000G	146	Y306000D1200000G	118
Y304000A1T000007	143	Y304500F12000007	144	Y305000001T500007	145	Y305500D12500007	146	Y305BB2000000007	146	Y306000D200000T	118
Y304000A1T00000G	143	Y304500F1200000G	144	Y305000001T50000G	145	Y305500D1250000G	146	Y305BB200000000G	146	Y306000D200000G	118
Y304000A1T500007	143	Y304500F12500007	144	Y30500000A00000007	145	Y305500D1T000007	146	Y305BB201T000007	146	Y306000F000000T	118
Y304000A1T50000G	143	Y304500F1250000G	144	Y30500000A0000000G	145	Y305500D1T00000G	146	Y305BB201T00000G	146	Y306000F160000T	118
Y304000D00000007	143	Y304500F1T000007	144	Y3050000A12000007	145	Y305500D1T500007	146	Y305BB2012500007	146	Y306000F1200000T	118
Y304000D0000000G	143	Y304500F1T00000G	144	Y3050000A1200000G	145	Y305500D1T50000G	146	Y305BB201250000G	146	Y306000F1200000G	118
Y304000D12000007	143	Y304500F1T500007	144	Y3050000A12500007	145	Y305500F00000007	146	Y305BB201T000007	146	Y306000F2160000T	118
Y304000D1200000G	143	Y304500F1T50000G	144	Y3050000A1250000G	145	Y305500F0000000G	146	Y305BB201T00000G	146	Y306000F2200000T	118
Y304000D12500007	143	Y3048A2000000007	144	Y3050000A1T000007	145	Y305500F12000007	146	Y305BB201T500007	146	Y3064500000000T	118
Y304000D1250000G	143	Y3048A200000000G	144	Y3050000A1T00000G	145	Y305500F1200000G	146	Y305BB201T50000G	146	Y30645001160000T	118
Y304000D1T000007	143	Y3048A2012000007	144	Y3050000A1T500007	145	Y305500F12500007	146	Y305BB2A00000007	146	Y30645001200000T	119
Y304000D1T00000G	143	Y3048A201200000G	144	Y3050000A1T50000G	145	Y305500F1250000G	146	Y305BB2A0000000G	146	Y30645001200000G	119
Y304000D1T500007	143	Y3048A2012500007	144	Y3050000D00000007	145	Y305500F1T000007	146	Y305BB2A12000007	146	Y30645002200000T	119
Y304000D1T50000G	143	Y3048A201250000G	144	Y3050000D0000000G	145	Y305500F1T00000G	146	Y305BB2A1200000G	146	Y30645002200000G	119
Y304000F00000007	143	Y3048A201T000007	144	Y3050000D12000007	145	Y305500F1T500007	146	Y305BB2A12500007	146	Y3064500A0000000T	118
Y304000F0000000G	143	Y3048A201T00000G	144	Y3050000D1200000G	145	Y305500F1T50000G	146	Y305BB2A1250000G	146	Y3064500A1160000T	118
Y304000F12000007	143	Y3048A201T500007	144	Y3050000D12500007	145	Y305600000000007	146	Y305BB2A1T000007	146	Y3064500A1200000T	119
Y304000F1200000G	143	Y3048A201T50000G	144	Y3050000D1250000G	145	Y30560000000000G	146	Y305BB2A1T00000G	146	Y3064500A1200000G	119
Y304000F12500007	143	Y3048A2A00000007	144	Y3050000D1T000007	145	Y305600012000007	146	Y305BB2A1T500007	146	Y3064500A2200000T	119
Y304000F1250000G	143	Y3048A2A0000000G	144	Y3050000D1T00000G	145	Y30560001200000G	146	Y305BB2A1T50000G	146	Y3064500A2200000G	119
Y304000F1T000007	143	Y3048A2A12000007	144	Y3050000D1T500007	145	Y305600012500007	146	Y305BB2D00000007	146	Y3064500D000000T	118
Y304000F1T00000G	143	Y3048A2A1200000G	144	Y3050000D1T50000G	145	Y30560001250000G	146	Y305BB2D0000000G	146	Y3064500D1160000T	118
Y304000F1T500007	143	Y3048A2A12500007	144	Y3050000F00000007	145	Y30560001T000007	146	Y305BB2D12000007	146	Y3064500D1200000T	119
Y304000F1T50000G	143	Y3048A2A1250000G	144	Y3050000F0000000G	145	Y30560001T00000G	146	Y305BB2D1200000G	146	Y3064500D1200000G	119
Y304450000000007	143	Y3048A2A1T000007	144	Y3050000F12000007	145	Y30560001T500007	146	Y305BB2D12500007	146	Y3064500D2200000T	119
Y30445000000000G	143	Y3048A2A1T00000G	144	Y3050000F1200000G	145	Y30560001T50000G	146	Y305BB2D1250000G	146	Y3064500D2200000G	119
Y304450012000007	144	Y3048A2A1T500007	144	Y3050000F12500007	145	Y305600A00000007	146	Y305BB2D1T000007	146	Y3064500F0000000T	118
Y30445001200000G	144	Y3048A2A1T50000G	144	Y3050000F1250000G	145	Y305600A0000000G	146	Y305BB2D1T00000G	146	Y3064500F160000T	118
Y304450012500007	144	Y3048A2D00000007	144	Y3050000F1T000007	145	Y305600A12000007	146	Y305BB2D1T500007	146	Y3064500F1200000T	119
Y30445001250000G	144	Y3048A2D0000000G	144	Y3050000F1T00000G	145	Y305600A1200000G	146	Y305BB2D1T50000G	146	Y3064500F1200000G	119
Y30445001T000007	144	Y3048A2D12000007	144	Y3050000F1T500007	145	Y305600A12500007	146	Y305BB2F00000007	146	Y3064500F2200000T	119
Y30445001T00000G	144	Y3048A2D1200000G	144	Y3050000F1T50000G	145	Y305600A1250000G	146	Y305BB2F0000000G	146	Y3064500F2C00000T	119
Y30445001T500007	144	Y3048A2D12500007	144	Y305450000000007	145	Y305600A1T000007	146	Y305BB2F12000007	146	Y306500000000000T	119
Y30445001T50000G	144	Y3048A2D1250000G	144	Y30545000000000G	145	Y305600A1T00000G	146	Y305BB2F1200000G	146	Y306500001200000T	119
Y30445001T500007	144	Y3048A2D1T000007	144	Y30545000000000G	145	Y305600A1T500007	146	Y305BB2F12500007	146	Y306500001200000G	119
Y30445001T50000G	144	Y3048A2D1T00000G	144	Y30545000000000G	145	Y305600A1T50000G	146	Y305BB2F1250000G	146	Y306500001600000T	119
Y3044500A00000007	143	Y3048A2D1T500007	144	Y3054500012000007	145	Y305600A1T50000G	146	Y305BB2F1250000G	146	Y306500002160000T	119
Y3044500A0000000G	143	Y3048A2D1T50000G	144	Y305450001200000G	145	Y305600D00000007	146	Y305BB2F1T000007	146	Y306500002200000T	119
Y3044500A12000007	144	Y3048A2D1T500007	144	Y305450012500007	145	Y305600D0000000G	146	Y305BB2F1T00000G	146	Y306500002C00000T	119
Y3044500A1200000G	144	Y3048A2D1T50000G	144	Y30545001250000G	145	Y305600D12000007	146	Y305BB2F1T00000G	146	Y3065000A0000000T	119
Y3044500A12500007	144	Y3048A2F00000007	144	Y30545001T000007	146	Y305600D1200000G	146	Y305BB2F1T500007	146	Y3065000A0000000G	119
Y3044500A1250000G	144	Y3048A2F0000000G	144	Y30545001T00000G	146	Y305600D1200000G	146	Y305BB2F1T50000G	146	Y3065000A1200000T	119
Y3044500A1T000007	144	Y3048A2F12000007	144	Y30545001T500007	146	Y305600D12500007	146	Y305M45000000007	146	Y3065000A1600000T	119
Y3044500A1T00000G	144	Y3048A2F1200000G	144	Y30545001T50000G	146	Y305600D1250000G	146	Y305M4500000000G	146	Y3065000A1600000G	119
Y3044500A1T500007	144	Y3048A2F12500007	144	Y3054500A00000007	145	Y305600D1250000G	146	Y305M45012000007	146	Y3065000A2200000T	119
Y3044500A1T50000G	144	Y3048A2F1250000G	144	Y3054500A0000000G	145	Y305600D1T000007	146	Y305M4501200000G	146	Y3065000A2200000G	119
Y3044500A1T500007	144	Y3048A2F1T000007	144	Y3054500A0000000G	145	Y305600D1T00000G	146	Y305M45012500007	146	Y3065000A2C00000T	119
Y3044500A1T50000G	144	Y3048A2F1T00000G	144	Y3054500A12000007	145	Y305600D1T00000G	146	Y305M4501250000G	146	Y3065000D0000000T	119
Y3044500A00000007	143	Y3048A2F1T500007	144	Y3054500A1200000G	145	Y305600D1T500007	146	Y305M4501250000G	146	Y3065000D0000000G	119
Y3044500A0000000G	143	Y3048A2F1T50000G	144	Y3054500A1200000G	145	Y305600D1T50000G	146	Y305M4501250000G	146	Y3065000D1200000T	119

# Alphabetical list of products references used in this catalogue

References	Page	References	Page	References	Page	References	Page	References	Page	References	Page
Y306600F2200000T	119	Y307000D1T50000T	124	Y307BA2A1200000T	125	Y30945002T5J1007	164	Y309BC20125J1007	164	Y3105000220J1007	170
Y306600F2C00000T	119	Y307000D2200000T	124	Y307BA2A1250000T	125	Y30945002T5J100G	164	Y309BC20125J100G	164	Y3105000225J100G	170
Y306BA2000000000T	119	Y307000D2250000T	124	Y307BA2A1T00000T	125	Y3095000000J1007	164	Y309BC201T0J1007	164	Y3105000225J100G	170
Y306BA201160000T	119	Y307000D2T00000T	124	Y307BA2A1T50000T	125	Y3095000000J100G	164	Y309BC201T0J100G	164	Y3105000225J100G	170
Y306BA201200000T	119	Y307000D2T50000T	124	Y307BA2A2200000T	125	Y3095000120J1007	164	Y309BC201T5J1007	164	Y31050002T0J1007	170
Y306BA201260000T	119	Y307000F0000000T	124	Y307BA2D2250000T	125	Y3095000120J100G	164	Y309BC201T5J100G	164	Y31050002T0J100G	170
Y306BA202200000T	119	Y307000F1200000T	124	Y307BA2A2T00000T	125	Y3095000125J1007	164	Y309BC20220J1007	164	Y31050002T5J1007	170
Y306BA202260000T	119	Y307000F1250000T	124	Y307BA2A2T50000T	125	Y3095000125J100G	164	Y309BC20220J100G	164	Y31050002T5J100G	170
Y306BA2A0000000T	119	Y307000F1T00000T	124	Y307BA2D0000000T	125	Y30950001T0J1007	164	Y309BC20225J1007	164	Y3106000000J1007	170
Y306BA2A1160000T	119	Y307000F1T50000T	124	Y307BA2D1200000T	125	Y30950001T0J100G	164	Y309BC20225J100G	164	Y3106000000J100G	170
Y306BA2A1200000T	119	Y307000F2200000T	124	Y307BA2D1250000T	125	Y30950001T5J1007	164	Y309BC202T0J1007	164	Y3106000120J1007	170
Y306BA2A2160000T	119	Y307000F2250000T	124	Y307BA2D1T00000T	125	Y30950001T5J100G	164	Y309BC202T0J100G	164	Y3106000120J100G	170
Y306BA2A2200000T	119	Y307000F2T00000T	124	Y307BA2D1T50000T	125	Y3095000220J1007	164	Y309BC202T5J1007	164	Y3106000125J1007	170
Y306BA2A2C00000T	119	Y307000F2T50000T	124	Y307BA2D2200000T	125	Y3095000220J100G	164	Y309BC202T5J100G	164	Y3106000125J100G	170
Y306BA2D0000000T	119	Y30745000000000T	124	Y307BA2D2250000T	125	Y3095000225J1007	164	Y309M4500000J1007	164	Y31060001T0J1007	170
Y306BA2D1160000T	119	Y30745001200000T	124	Y307BA2D2T00000T	125	Y3095000225J100G	164	Y309M4500000J100G	164	Y31060001T0J100G	170
Y306BA2D1200000T	119	Y30745001250000T	125	Y307BA2D2T50000T	125	Y30950002T0J1007	164	Y309M450120J1007	164	Y31060001T5J1007	170
Y306BA2D2160000T	119	Y30745001T00000T	125	Y307BA2F0000000T	125	Y30950002T0J100G	164	Y309M450120J100G	164	Y31060001T5J100G	170
Y306BA2D2200000T	119	Y30745001T50000T	125	Y307BA2F1200000T	125	Y30950002T5J1007	164	Y309M450125J1007	164	Y310600020J1007	170
Y306BA2D2200000T	119	Y30745002200000T	125	Y307BA2F1250000T	125	Y30950002T5J100G	164	Y309M450125J100G	164	Y310600020J100G	170
Y306BA2D2C00000T	119	Y30745002250000T	125	Y307BA2F1T00000T	125	Y3095000000J1007	164	Y309M450125J100G	164	Y3106000225J100G	170
Y306BA2F160000T	119	Y30745002T00000T	125	Y307BA2F1T50000T	125	Y3096000000J100G	164	Y309M4501T0J1007	164	Y3106000225J100G	170
Y306BA2F1200000T	119	Y30745002T50000T	125	Y307BA2F2200000T	125	Y3096000000J100G	164	Y309M4501T0J100G	164	Y3106000225J100G	170
Y306BA2F2160000T	119	Y3074500A0000000T	124	Y307BA2F2250000T	125	Y3096000120J1007	164	Y309M4501T5J1007	164	Y3106000225J100G	170
Y306BA2F2200000T	119	Y3074500A1200000T	124	Y307BA2F2T00000T	125	Y3096000120J100G	164	Y309M4501T5J100G	164	Y31060002T0J100G	170
Y306BA2F2C00000T	119	Y3074500A1250000T	125	Y307BA2F2T50000T	125	Y3096000125J1007	164	Y309M450220J1007	164	Y31060002T5J1007	170
Y306BB2000000000T	119	Y3074500A1T00000T	125	Y307M4500000000T	125	Y30960001T0J1007	164	Y309M450225J1007	164	Y3107700000J1007	170
Y306BB201160000T	119	Y3074500A1T50000T	125	Y307M4501200000T	125	Y30960001T0J100G	164	Y309M450225J100G	164	Y3107700000J100G	170
Y306BB201200000T	119	Y3074500A2200000T	125	Y307M4501250000T	125	Y30960001T5J1007	164	Y309M4502T0J1007	164	Y3107700120J1007	170
Y306BB202160000T	119	Y3074500A2250000T	125	Y307M4501T00000T	125	Y30960001T5J100G	164	Y309M4502T0J100G	164	Y3107700120J100G	170
Y306BB202200000T	119	Y3074500A2T00000T	125	Y307M4501T50000T	125	Y3096000220J1007	164	Y309M4502T5J1007	164	Y3107700125J1007	170
Y306BB202C00000T	119	Y3074500A2T50000T	125	Y307M4502200000T	125	Y3096000220J100G	164	Y309M4502T5J100G	164	Y3107700125J100G	170
Y306BB2A00000000T	119	Y3074500D0000000T	124	Y307M4502250000T	125	Y3096000225J1007	164	Y309M700000J1007	164	Y31077001T0J1007	170
Y306BB2A1160000T	119	Y3074500D1200000T	125	Y307M4502T00000T	125	Y3096000225J100G	164	Y309M700000J100G	164	Y31077001T0J100G	170
Y306BB2A1200000T	119	Y3074500D1250000T	125	Y307M4502T50000T	125	Y30960002T0J1007	164	Y309M770120J1007	164	Y31077001T5J1007	170
Y306BB2A2160000T	119	Y3074500D1T00000T	125	Y307M45A0000000T	125	Y30960002T0J100G	164	Y309M770120J100G	164	Y31077001T5J100G	170
Y306BB2A2200000T	119	Y3074500D1T50000T	125	Y307M45A1200000T	125	Y30960002T5J1007	164	Y309M770125J1007	164	Y3107700220J1007	170
Y306BB2A2C00000T	119	Y3074500D2200000T	125	Y307M45A1250000T	125	Y30960002T5J100G	164	Y309M770125J100G	164	Y3107700220J100G	170
Y306BB2A20000000T	119	Y3074500D2250000T	125	Y307M45A1T00000T	125	Y30960002T5J100G	164	Y309M7701T0J1007	164	Y3107700225J1007	170
Y306BB2A2160000T	119	Y3074500D2T00000T	125	Y307M45A1T50000T	125	Y30960002T5J100G	164	Y309M7701T0J100G	164	Y3107700225J100G	170
Y306BB2A2200000T	119	Y3074500D2T50000T	125	Y307M45A2200000T	125	Y30960002T0J1007	164	Y309M7701T5J1007	164	Y3107700225J100G	170
Y306BB2D00000000T	119	Y3074500F0000000T	124	Y307M45A2250000T	125	Y3097700120J1007	164	Y309M7701T5J100G	164	Y31077002T0J1007	170
Y306BB2D1160000T	119	Y3074500F1200000T	125	Y307M45A2T00000T	125	Y3097700120J100G	164	Y309M7701T5J100G	164	Y31077002T0J1007	170
Y306BB2D1200000T	119	Y3074500F1250000T	125	Y307M45A2T50000T	125	Y3097700125J1007	164	Y309M770220J1007	164	Y31077002T0J1007	170
Y306BB2D2160000T	119	Y3074500F1T00000T	125	Y307M45A2T50000T	125	Y3097700125J100G	164	Y309M770225J1007	164	Y31077002T5J1007	170
Y306BB2D2200000T	119	Y3074500F1T50000T	125	Y307M45A2T50000T	125	Y30977001T0J1007	164	Y309M770225J100G	164	Y31077002T5J100G	170
Y306BB2D2C00000T	119	Y3074500F2200000T	125	Y307M45A2T50000T	125	Y30977001T0J100G	164	Y309M770225J100G	164	Y31077002T5J100G	170
Y306BB2D20000000T	119	Y3074500F2250000T	125	Y307M45A2T50000T	125	Y30977001T5J1007	164	Y309M7702T0J1007	164	Y31077002T5J100G	170
Y306BB2D2160000T	119	Y3074500F2T00000T	125	Y307M45A1T00000T	125	Y30977001T5J100G	164	Y309M7702T0J100G	164	Y31077002T5J100G	170
Y306BB2D2200000T	119	Y3074500F2T50000T	125	Y307M45A1T50000T	125	Y30977001T5J100G	164	Y309M7702T5J1007	164	Y31077002T5J100G	170
Y306BB2D2C00000T	119	Y3074500F2T50000T	125	Y307M45A1T50000T	125	Y30977001T5J100G	164	Y309M7702T5J100G	164	Y31077002T5J100G	170
Y306BB2D00000000T	119	Y3074500D2200000T	125	Y307M45A1T50000T	125	Y3097700000J1007	164	Y309M7702T5J100G	164	Y31077002T5J100G	170
Y306BB2D1160000T	119	Y3074500D2250000T	125	Y307M45A1T50000T	125	Y3097700000J100G	164	Y309M7702T5J100G	164	Y31077002T5J100G	170
Y306BB2D1200000T	119	Y3074500D2T00000T	125	Y307M45A1T50000T	125	Y3097700000J100G	164	Y309M7702T5J100G	164	Y31077002T5J100G	170
Y306BB2D1200000T	119	Y3074500D2T50000T	125	Y307M45A1T50000T	125	Y3097700000J100G	164	Y309M7702T5J100G	164	Y31077002T5J100G	170
Y306BB2D2160000T	119	Y3074500D2T50000T	125	Y307M45A2200000T	125	Y3097700120J1007	164	Y309M7702T5J100G	164	Y31077002T5J100G	170
Y306BB2D2200000T	119	Y3074500D2T50000T	125	Y307M45A2250000T	125	Y3097700120J100G	164	Y309M7702T5J100G	164	Y31077002T5J100G	170
Y306BB2D2C00000T	119	Y3074500D2T50000T	125	Y307M45A2250000T	125	Y3097700120J100G	164	Y309M7702T5J100G	164	Y31077002T5J100G	170
Y306BB2A00000000T	119	Y3074500D1200000T	125	Y307M45A2T00000T	125	Y3097700125J1007	164	Y309M7702T5J100G	164	Y31077002T5J100G	170
Y306BB2A1160000T	119	Y3074500D1250000T	125	Y307M45A2T00000T	125	Y3097700125J100G	164	Y309M7702T5J100G	164	Y31077002T5J100G	170
Y306BB2A1200000T	119	Y3074500D1T00000T	125	Y307M45A2T00000T	125	Y3097700125J100G	164	Y309M7702T5J100G	164	Y31077002T5J100G	170
Y306BB2A2160000T	119	Y3074500D1T50000T	125	Y307M45A2T50000T	125	Y30977001T0J1007	164	Y309M7702T5J100G	164	Y31077002T5J100G	170
Y306BB2A2200000T	119	Y3074500D1T50000T	125	Y307M45A2T50000T	125	Y30977001T0J100G	164	Y309M7702T5J100G	164	Y31077002T5J100G	170
Y306BB2A2C00000T	119	Y3074500D2200000T	125	Y307M45A1250000T	125	Y30977001T5J1007	164	Y309M7702T5J100G	164	Y31077002T5J100G	170
Y306BB2A20000000T	119	Y3074500D2250000T	125	Y307M45A1T00000T	125	Y30977001T5J100G	164	Y309M7702T5J100G	164	Y31077002T5J100G	170
Y306BB2A2160000T	119	Y3074500D2T00000T	125	Y307M45A1T50000T	125	Y30977001T5J100G	164	Y309M7702T5J100G	164	Y31077002T5J100G	170
Y306BB2A2200000T	119	Y3074500D2T50000T	125	Y307M45A1T50000T	125	Y30977001T5J100G	164	Y309M7702T5J100G	164	Y31077002T5J100G	170
Y306BB2A2C00000T	119	Y3074500D2T50000T	125	Y307M45A1T50000T	125	Y30977001T5J100G	164	Y309M7702T5J100G	164	Y31077002T5J100G	170
Y306BB2D00000000T	119	Y3074500D2T50000T	125	Y307M45A1T50000T</							



# Alphabetical list of products references used in this catalogue

References	Page	References	Page	References	Page	References	Page	References	Page	References	Page
Y3108C202T5J1007	170	Y3C200010000100T	114	Y3C6520022BH40YU	132	Y3C8110022B000WU	134	Y3E8060022BH40UT	137	Y3G14500120J1007	160
Y3108C202T5J100G	170	Y3C20001000E100T	114	Y3C6520022BH40ZU	132	Y3C8110022B000XU	134	Y3E8060022BH40VT	137	Y3G14500120J100G	160
Y310M450000J1007	170	Y3C20001000H200T	114	Y3C6550022B000YU	132	Y3C8110022B000YU	134	Y3E8060022BH40WT	137	Y3G14500125J1007	160
Y310M450000J100G	170	Y3C200011120100T	114	Y3C6550022B000VU	132	Y3C8110022B000ZU	134	Y3E8060022BH40XT	137	Y3G14500125J100G	160
Y310M450120J1007	170	Y3C20001112E100T	114	Y3C6550022B000WU	132	Y3C8110022BH40U	134	Y3E8060022BH40YT	137	Y3G145001T0J1007	160
Y310M450120J100G	170	Y3C20001112H200T	114	Y3C6550022B000XU	132	Y3C8110022BH40VU	134	Y3E8060022BH40ZT	137	Y3G145001T0J100G	160
Y310M450125J1007	170	Y3C200011250100T	114	Y3C6550022B000YU	132	Y3C8110022BH40WU	134	Y3E8070022B000UT	137	Y3G145001T5J1007	160
Y310M450125J100G	170	Y3C20001125E100T	114	Y3C6550022B000ZU	132	Y3C8110022BH40YU	134	Y3E8070022B000VT	137	Y3G145001T5J100G	160
Y310M4501T0J1007	170	Y3C20001125H200T	114	Y3C6550022BH40U	132	Y3C8110022BH40VU	134	Y3E8070022B000WT	137	Y3G14500220J1007	160
Y310M4501T0J100G	170	Y3C200012A00100T	114	Y3C6550022BH40VU	132	Y3C8110022BH40ZU	134	Y3E8070022B000XT	137	Y3G14500220J100G	160
Y310M4501T5J1007	170	Y3C200012A0E100T	114	Y3C6550022BH40WU	132	Y3E6450022B000VU	135	Y3E8070022B000YT	137	Y3G14500225J1007	160
Y310M4501T5J100G	170	Y3C200012A0H200T	114	Y3C6550022BH40XU	132	Y3E6450022B000WT	135	Y3E8070022B000ZT	137	Y3G14500225J100G	160
Y310M450220J1007	170	Y3C3000000E200T	115	Y3C6550022BH40YU	132	Y3E6450022B000WU	135	Y3E8070022B000UT	137	Y3G14500225J1007	160
Y310M450220J100G	170	Y3C30000120E200T	115	Y3C6550022BH40ZU	132	Y3E6450022B000XT	135	Y3E8070022B000VT	137	Y3G14500225J100G	160
Y310M450225J1007	170	Y3C30000125E200T	115	Y3C7460022B000U	133	Y3E6450022B000YU	135	Y3E8070022B000WT	137	Y3G1450025J1007	160
Y310M450225J100G	170	Y3C3000F00E200T	115	Y3C7460022B000VU	133	Y3E6450022B000ZU	135	Y3E8070022B000XT	137	Y3G1450025J100G	160
Y310M4502T0J1007	170	Y3C3000F120E200T	115	Y3C7460022BH40U	133	Y3E6450022BH40VU	135	Y3E8070022B000YT	137	Y3G15000000J1007	160
Y310M4502T0J100G	170	Y3C3000F125E200T	115	Y3C7460022BH40VU	133	Y3E6450022BH40WU	135	Y3E8070022B000ZT	137	Y3G15000000J100G	160
Y310M4502T5J1007	170	Y3C450000000000T	120	Y3C7490022B000U	133	Y3E6450022BH40YT	135	Y3E8080022B000UT	137	Y3G15000010J1007	160
Y310M4502T5J100G	170	Y3C450001160000T	120	Y3C7490022B000VU	133	Y3E6450022BH40ZT	135	Y3E8080022B000VT	137	Y3G15000010J100G	160
Y310M770000J1007	170	Y3C450001200000T	120	Y3C7490022BH40U	133	Y3E6450022B0000T	135	Y3E8080022B000WT	137	Y3G15000025J1007	160
Y310M770000J100G	170	Y3C450001250000T	120	Y3C7490022BH40VU	133	Y3E6450022B0000T	135	Y3E8080022B000XT	137	Y3G15000025J100G	160
Y310M770120J1007	170	Y3C450002200000T	120	Y3C7490022BH40YT	133	Y3E6450022B0000T	135	Y3E8080022B000ZT	137	Y3G150000T0J1007	160
Y310M770120J100G	170	Y3C450002C00000T	120	Y3C7510022B000U	133	Y3E6480022B0000T	135	Y3E8080022B000UT	137	Y3G150000T0J100G	160
Y310M770125J1007	170	Y3C450002D50000T	120	Y3C7510022BH40U	133	Y3E6480022B0000T	135	Y3E8080022B000VT	137	Y3G150000T5J1007	160
Y310M770125J100G	170	Y3C450002D50000T	120	Y3C7510022BH40VU	133	Y3E6480022B0000T	135	Y3E8080022B000WT	137	Y3G150000T5J100G	160
Y310M7701T0J1007	170	Y3C4500A0000000T	120	Y3C7530022B000U	133	Y3E6480022B0000T	135	Y3E8080022B000XT	137	Y3G150000T5J100G	160
Y310M7701T0J100G	170	Y3C4500A1160000T	120	Y3C7530022B000VU	133	Y3E6480022B0000T	135	Y3E8080022B000YT	137	Y3G150000T5J100G	160
Y310M7701T5J1007	170	Y3C4500A1200000T	120	Y3C7530022BH40U	133	Y3E6480022B0000T	135	Y3E8080022B000ZT	137	Y3G150000T5J100G	160
Y310M7701T5J100G	170	Y3C4500A1200000T	120	Y3C7530022BH40VU	133	Y3E6480022B0000T	135	Y3E8080022B000UT	137	Y3G150000T5J100G	160
Y310M7701T5J1007	170	Y3C4500A1250000T	120	Y3C7530022BH40YU	133	Y3E6480022B0000T	135	Y3E8080022B000VT	137	Y3G150000T5J100G	160
Y310M7701T5J100G	170	Y3C4500A2200000T	120	Y3C7560022B000U	133	Y3E6480022B0000T	135	Y3E8080022B000WT	137	Y3G150000T5J100G	160
Y310M770220J1007	170	Y3C4500A2C00000T	120	Y3C7560022B000VU	133	Y3E6480022B0000T	135	Y3E8080022B000XT	137	Y3G150000T5J100G	160
Y310M770220J100G	170	Y3C4500A2C00000T	120	Y3C7560022BH40U	133	Y3E6480022B0000T	135	Y3E8080022B000YT	137	Y3G150000T5J100G	160
Y310M770225J1007	170	Y3C4500A2D50000T	120	Y3C7560022BH40VU	133	Y3E6480022B0000T	135	Y3E8080022B000ZT	137	Y3G150000T5J100G	160
Y310M770225J100G	170	Y3C4500A2D50000T	120	Y3C7560022BH40YU	133	Y3E6480022B0000T	135	Y3E8080022B000UT	137	Y3G150000T5J100G	160
Y310M7702T0J1007	170	Y3C4500D0000000T	120	Y3C8060022B000U	134	Y3E6500022B0000T	135	Y3E8080022B000VT	137	Y3G150000T5J100G	160
Y310M7702T0J100G	170	Y3C4500D1160000T	120	Y3C8060022B000VU	134	Y3E6500022B0000T	135	Y3E8080022B000WT	137	Y3G150000T5J100G	160
Y310M7702T5J1007	170	Y3C4500D1200000T	120	Y3C8060022B000YU	134	Y3E6500022B0000T	135	Y3E8080022B000XT	137	Y3G150000T5J100G	160
Y310M7702T5J100G	170	Y3C4500D1250000T	120	Y3C8060022B000ZU	134	Y3E6500022B0000T	135	Y3E8080022B000YT	137	Y3G150000T5J100G	160
Y3A100001E10000T	107	Y3C4500D2200000T	120	Y3C8060022B000YU	134	Y3E6500022B0000T	135	Y3E8080022B000ZT	137	Y3G150000T5J100G	160
Y3A100001E1F100T	107	Y3C4500D2C00000T	120	Y3C8060022B000ZU	134	Y3E6500022B0000T	135	Y3E8080022B000UT	137	Y3G150000T5J100G	160
Y3A100001E20000T	107	Y3C4500D2C50000T	120	Y3C8060022BH40U	134	Y3E6500022B0000T	135	Y3E8080022B000VT	137	Y3G150000T5J100G	160
Y3A100001E2F100T	107	Y3C4500D2D50000T	120	Y3C8060022BH40VU	134	Y3E6500022B0000T	135	Y3E8080022B000WT	137	Y3G150000T5J100G	160
Y3A100001E30000T	107	Y3C4500F0000000T	120	Y3C8060022BH40WU	134	Y3E6500022B0000T	135	Y3E8080022B000XT	137	Y3G150000T5J100G	160
Y3A100001E3F100T	107	Y3C4500F1160000T	120	Y3C8060022BH40XU	134	Y3E6500022B0000T	135	Y3E8080022B000YT	137	Y3G150000T5J100G	160
Y3A108001E10000T	107	Y3C4500F1200000T	120	Y3C8060022BH40YU	134	Y3E6500022B0000T	135	Y3E8080022B000ZT	137	Y3G150000T5J100G	160
Y3A108001E1F100T	107	Y3C4500F1250000T	120	Y3C8060022BH40VU	134	Y3E6500022B0000T	135	Y3E8080022B000UT	137	Y3G150000T5J100G	160
Y3A108001E20000T	107	Y3C4500F2200000T	120	Y3C8070022B000U	134	Y3E6500022B0000T	135	Y3E8080022B000VT	137	Y3G150000T5J100G	160
Y3A108001E2F100T	107	Y3C4500F2C00000T	120	Y3C8070022B000VU	134	Y3E6500022B0000T	135	Y3E8080022B000WT	137	Y3G150000T5J100G	160
Y3A108001E30000T	107	Y3C4500F2C50000T	120	Y3C8070022B000YU	134	Y3E6500022B0000T	135	Y3E8080022B000XT	137	Y3G150000T5J100G	160
Y3A108001E3F100T	107	Y3C4500F2D50000T	120	Y3C8070022B000ZU	134	Y3E6500022B0000T	135	Y3E8080022B000YT	137	Y3G150000T5J100G	160
Y3A121001E10000T	107	Y3C6450022B000U	132	Y3C8070022B000YU	134	Y3E6500022B0000T	135	Y3E8080022B000ZT	137	Y3G150000T5J100G	160
Y3A121001E1F100T	107	Y3C6450022B000VU	132	Y3C8070022BH40U	134	Y3E6500022B0000T	135	Y3E8080022B000UT	137	Y3G150000T5J100G	160
Y3A121001E20000T	107	Y3C6450022B000WU	132	Y3C8070022BH40VU	134	Y3E6500022B0000T	135	Y3E8080022B000VT	137	Y3G150000T5J100G	160
Y3A121001E2F100T	107	Y3C6450022B000XU	132	Y3C8070022BH40YU	134	Y3E6500022B0000T	135	Y3E8080022B000WT	137	Y3G150000T5J100G	160
Y3A121001E30000T	107	Y3C6450022B000YU	132	Y3C8070022BH40WU	134	Y3E6500022B0000T	135	Y3E8080022B000XT	137	Y3G150000T5J100G	160
Y3A121001E3F100T	107	Y3C6450022B000ZU	132	Y3C8070022BH40XU	134	Y3E6500022B0000T	135	Y3E8080022B000YT	137	Y3G150000T5J100G	160
Y3A200001E10000T	108	Y3C6450022BH40U	132	Y3C8080022B000U	134	Y3E6500022B0000T	135	Y3E8080022B000ZT	137	Y3G150000T5J100G	160
Y3A200001E1F100T	108	Y3C6450022BH40VU	132	Y3C8080022B000VU	134	Y3E6500022B0000T	135	Y3E8080022B000UT	137	Y3G150000T5J100G	160
Y3A200001E20000T	108	Y3C6450022BH40WU	132	Y3C8080022B000YU	134	Y3E6500022B0000T	135	Y3E8080022B000VT	137	Y3G150000T5J100G	160
Y3A200001E2F100T	108	Y3C6450022BH40XU	132	Y3C8080022B000ZU	134	Y3E6500022B0000T	135	Y3E8080022B000WT	137	Y3G150000T5J100G	160
Y3A200001E30000T	108	Y3C6450022BH40YU	132	Y3C8080022B000YU	134	Y3E6500022B0000T	135	Y3E8080022B000XT	137	Y3G150000T5J100G	160
Y3A200001E3F100T	108	Y3C6450022BH40VU	132	Y3C8080022B000YU	134	Y3E6500022B0000T	135	Y3E8080022B000YT	137	Y3G150000T5J100G	160
Y3A200001E60000T	108	Y3C6450022BH40WU	132	Y3C8080022B000ZU	134	Y3E6500022B0000T	135	Y3E8080022B000ZT	137	Y3G150000T5J100G	160
Y3A200001E6F100T	108	Y3C6450022BH40XU	132	Y3C8080022B000YU	134	Y3E6500022B0000T	135	Y3E8080022B000UT	137	Y3G150000T5J100G	160
Y3A208001E10000T	108	Y3C6480022B000U	132	Y3C8080022B000VU	134	Y3E6500022B0000T	135	Y3E8080022B000VT	137	Y3G150000T5J100G	160
Y3A208001E1F100T	108	Y3C6480022B000VU	132	Y3C8080022B000YU	134	Y3E6500022B0000T	135	Y3E8080022B000WT	137	Y3G150000T5J100G	160
Y3A208001E20000T	108	Y3C6480022B000WU	132	Y3C8080022B000YU	134	Y3E6500022B0000T	135	Y3E8080022B000XT	137	Y3G150000T	



# Alphabetical list of products references used in this catalogue

References	Page	References	Page	References	Page	References	Page	References	Page	References	Page
Y3J160001T5J1007	166	Y3J1M4502T0J1007	166	Y3J27700120J1007	168	Y3J2M7701T5J1007	168	Y3M1500A220000T	126	Y3N100001200000T	128
Y3J160001T5J100G	166	Y3J1M4502T0J100G	166	Y3J27700120J100G	168	Y3J2M7701T5J100G	168	Y3M1500A225000T	126	Y3N10000120J100T	128
Y3J16000220J1007	166	Y3J1M4502T5J1007	166	Y3J27700125J1007	168	Y3J2M770220J1007	168	Y3M1500A2T0000T	126	Y3N100001250000T	128
Y3J16000220J100G	166	Y3J1M4502T5J100G	166	Y3J27700125J100G	168	Y3J2M770220J100G	168	Y3M1500A2T5000T	126	Y3N10000125J100T	128
Y3J16000225J1007	166	Y3J1M770000J1007	166	Y3J277001T0J1007	168	Y3J2M770225J1007	168	Y3M1500D000000T	126	Y3N100001T00000T	128
Y3J16000225J100G	166	Y3J1M770000J100G	166	Y3J277001T0J100G	168	Y3J2M770225J100G	168	Y3M1500D120000T	126	Y3N100001T0J100T	128
Y3J160002T0J1007	166	Y3J1M770120J1007	166	Y3J277001T5J1007	168	Y3J2M7702T0J1007	168	Y3M1500D125000T	126	Y3N100001T50000T	128
Y3J160002T0J100G	166	Y3J1M770120J100G	166	Y3J277001T5J100G	168	Y3J2M7702T0J100G	168	Y3M1500D1T0000T	126	Y3N100001T5J100T	128
Y3J160002T5J1007	166	Y3J1M770125J1007	166	Y3J27700220J1007	168	Y3J2M7702T5J1007	168	Y3M1500D1T5000T	126	Y3N100002200000T	128
Y3J160002T5J100G	166	Y3J1M770125J100G	166	Y3J27700220J100G	168	Y3J2M7702T5J100G	168	Y3M1500D220000T	126	Y3N10000220J100T	128
Y3J1770000J1007	166	Y3J1M7701T0J1007	166	Y3J27700225J1007	168	Y3J2M7702T5J100G	85	Y3M1500D225000T	126	Y3N100002250000T	128
Y3J1770000J100G	166	Y3J1M7701T0J100G	166	Y3J27700225J100G	168	Y3K1000100000009	85	Y3M1500D2T0000T	126	Y3N10000225J100T	128
Y3J17700120J1007	166	Y3J1M7701T5J1007	166	Y3J277002T0J1007	168	Y3K1000100001008	85	Y3M1500D2T5000T	126	Y3N100002T00000T	128
Y3J17700120J100G	166	Y3J1M7701T5J100G	166	Y3J277002T0J100G	168	Y3K1000100001009	85	Y3M1500F000000T	126	Y3N100002T0J100T	128
Y3J17700125J1007	166	Y3J1M770220J1007	166	Y3J277002T5J1007	168	Y3K10001000E1008	85	Y3M1500F120000T	126	Y3N100002T50000T	128
Y3J17700125J100G	166	Y3J1M770220J100G	166	Y3J277002T5J100G	168	Y3K10001000E1009	85	Y3M1500F125000T	126	Y3N100002T5J100T	128
Y3J177001T0J1007	166	Y3J1M770225J1007	166	Y3J2BA20000J1007	168	Y3K1000112000008	85	Y3M1500F1T0000T	126	Y3N145000000000T	128
Y3J177001T0J100G	166	Y3J1M770225J100G	166	Y3J2BA20000J100G	168	Y3K1000112000009	85	Y3M1500F1T5000T	126	Y3N1450000J100T	128
Y3J177001T5J1007	166	Y3J1M7702T0J1007	166	Y3J2BA20120J1007	168	Y3K1000112001008	85	Y3M1500F220000T	126	Y3N145001200000T	128
Y3J177001T5J100G	166	Y3J1M7702T0J100G	166	Y3J2BA20120J100G	168	Y3K1000112001009	85	Y3M1500F225000T	126	Y3N14500120J100T	128
Y3J17700220J1007	166	Y3J1M7702T5J1007	166	Y3J2BA20125J1007	168	Y3K10001120E1008	85	Y3M1500F2T0000T	126	Y3N14500125J100T	128
Y3J17700220J100G	166	Y3J1M7702T5J100G	166	Y3J2BA20125J100G	168	Y3K1000100000008	86	Y3M160000000000T	126	Y3N145001T00000T	128
Y3J17700225J1007	166	Y3J2000000J1007	168	Y3J2BA201T0J1007	168	Y3K2000100000009	86	Y3M160001200000T	127	Y3N145001T50000T	128
Y3J17700225J100G	166	Y3J2000000J100G	168	Y3J2BA201T0J100G	168	Y3K20001000E2008	86	Y3M160001250000T	127	Y3N145001T5J100T	128
Y3J177002T0J1007	166	Y3J20000120J1007	168	Y3J2BA201T5J1007	168	Y3K20001000E2009	86	Y3M160001T0000T	127	Y3N145001T5J100T	128
Y3J177002T0J100G	166	Y3J20000120J100G	168	Y3J2BA201T5J100G	168	Y3K2000112000008	86	Y3M160001T5000T	127	Y3N145001T5J100T	128
Y3J177002T5J1007	166	Y3J20000125J1007	168	Y3J2BA20220J1007	168	Y3K2000112000009	86	Y3M160001T5000T	127	Y3N145002200000T	128
Y3J177002T5J100G	166	Y3J20000125J100G	168	Y3J2BA20220J100G	168	Y3K2000112000009	86	Y3M16000220000T	127	Y3N14500220J100T	128
Y3J1BA20000J1007	166	Y3J200001T0J1007	168	Y3J2BA20225J1007	168	Y3K20001120E2008	86	Y3M16000225000T	127	Y3N145002250000T	128
Y3J1BA20000J100G	166	Y3J200001T0J100G	168	Y3J2BA20225J100G	168	Y3K20001120E2009	86	Y3M160002T0000T	127	Y3N14500225J100T	128
Y3J1BA20120J1007	166	Y3J200001T5J1007	168	Y3J2BA202T0J1007	168	Y3K2000112500008	86	Y3M160002T5000T	127	Y3N145002T00000T	128
Y3J1BA20120J100G	166	Y3J200001T5J100G	168	Y3J2BA202T0J100G	168	Y3K2000112500009	86	Y3M1600A000000T	126	Y3N145002T0J100T	128
Y3J1BA20125J1007	166	Y3J20000220J1007	168	Y3J2BA202T5J1007	168	Y3K20001125E2008	86	Y3M1600A100000T	126	Y3N145002T50000T	128
Y3J1BA20125J100G	166	Y3J20000220J100G	168	Y3J2BA202T5J100G	168	Y3K20001125E2009	86	Y3M1600A125000T	127	Y3N145002T5J100T	128
Y3J1BA201T0J1007	166	Y3J20000225J1007	168	Y3J2BB20000J1007	168	Y3L1000000000008	87	Y3M1600A1T0000T	127	Y3N150000000000T	128
Y3J1BA201T0J100G	166	Y3J20000225J100G	168	Y3J2BB20000J100G	168	Y3L1000000000009	87	Y3M1600A1T5000T	127	Y3N1500000J100T	128
Y3J1BA201T5J1007	166	Y3J200002T0J1007	168	Y3J2BB20120J1007	168	Y3L1000120000008	87	Y3M1600A220000T	127	Y3N150001200000T	128
Y3J1BA201T5J100G	166	Y3J200002T0J100G	168	Y3J2BB20120J100G	168	Y3L1000120000009	87	Y3M1600A225000T	127	Y3N15000120J100T	128
Y3J1BA20220J1007	166	Y3J200002T5J1007	168	Y3J2BB20125J1007	168	Y3L1210000000008	87	Y3M1600A2T0000T	127	Y3N150001250000T	128
Y3J1BA20220J100G	166	Y3J200002T5J100G	168	Y3J2BB20125J100G	168	Y3L1210120000008	87	Y3M1600A2T5000T	127	Y3N15000125J100T	128
Y3J1BA20225J1007	166	Y3J24500000J1007	168	Y3J2BB201T0J1007	168	Y3L1210120000009	87	Y3M1600D000000T	126	Y3N150001T00000T	128
Y3J1BA20225J100G	166	Y3J24500000J100G	168	Y3J2BB201T0J100G	168	Y3L1210120000009	87	Y3M1600D120000T	127	Y3N150001T0J100T	128
Y3J1BA202T0J1007	166	Y3J245000120J1007	168	Y3J2BB201T5J1007	168	Y3L1265000000008	87	Y3M1600D125000T	127	Y3N150001T50000T	128
Y3J1BA202T0J100G	166	Y3J245000120J100G	168	Y3J2BB201T5J100G	168	Y3L1265000000009	87	Y3M1600D1T0000T	127	Y3N150001T5J100T	128
Y3J1BA202T5J1007	166	Y3J24500125J1007	168	Y3J2BB20220J1007	168	Y3L1265120000008	87	Y3M1600D1T5000T	127	Y3N150002200000T	128
Y3J1BA202T5J100G	166	Y3J24500125J100G	168	Y3J2BB20220J100G	168	Y3L1265120000009	87	Y3M1600D220000T	127	Y3N15000220J100T	128
Y3J1BB20000J1007	166	Y3J245001T0J1007	168	Y3J2BB20225J1007	168	Y3L1335000000008	87	Y3M1600D225000T	127	Y3N150002250000T	128
Y3J1BB20000J100G	166	Y3J245001T0J100G	168	Y3J2BB20225J100G	168	Y3L1335000000009	87	Y3M1600D2T0000T	127	Y3N15000225J100T	128
Y3J1BB20120J1007	166	Y3J245001T5J1007	168	Y3J2BB202T0J1007	168	Y3L1335120000008	87	Y3M1600D2T5000T	127	Y3N150002T00000T	128
Y3J1BB20120J100G	166	Y3J245001T5J100G	168	Y3J2BB202T0J100G	168	Y3L1335120000009	87	Y3M1600F000000T	126	Y3N150002T0J100T	128
Y3J1BB20125J1007	166	Y3J24500220J1007	168	Y3J2BB202T5J1007	168	Y3L2175000000008	88	Y3M1600F100000T	127	Y3N150002T50000T	128
Y3J1BB20125J100G	166	Y3J24500220J100G	168	Y3J2BB202T5J100G	168	Y3L2175000000009	88	Y3M1600F125000T	127	Y3N150002T5J100T	128
Y3J1BB201T0J1007	166	Y3J24500225J1007	168	Y3J2BC20000J1007	168	Y3L2175120000008	88	Y3M1600F1T0000T	127	Y3N200000000000T	129
Y3J1BB201T0J100G	166	Y3J24500225J100G	168	Y3J2BC20000J100G	168	Y3L2175120000009	88	Y3M1600F1T5000T	127	Y3N2000000J100T	129
Y3J1BB201T5J1007	166	Y3J245002T0J1007	168	Y3J2BC20120J1007	168	Y3L2230000000008	88	Y3M1600F220000T	127	Y3N200001200000T	129
Y3J1BB201T5J100G	166	Y3J245002T0J100G	168	Y3J2BC20120J100G	168	Y3L2230000000009	88	Y3M1600F225000T	127	Y3N20000120J100T	129
Y3J1BB20220J1007	166	Y3J245002T5J1007	168	Y3J2BC20125J1007	168	Y3L2230120000008	88	Y3M1600F2T0000T	127	Y3N200001250000T	129
Y3J1BB20220J100G	166	Y3J245002T5J100G	168	Y3J2BC20125J100G	168	Y3L2230120000009	88	Y3M1600F2T5000T	127	Y3N20000125J100T	129
Y3J1BB20225J1007	166	Y3J25000000J1007	168	Y3J2BC201T0J1007	168	Y3L3000000000008	89	Y3M177000000000T	127	Y3N200001T00000T	129
Y3J1BB20225J100G	166	Y3J25000000J100G	168	Y3J2BC201T0J100G	168	Y3L3000000000009	89	Y3M17700120000T	127	Y3N200001T0J100T	129
Y3J1BB202T0J1007	166	Y3J25000120J1007	168	Y3J2BC201T5J1007	168	Y3L3000120000008	89	Y3M17700125000T	127	Y3N200001T50000T	129
Y3J1BB202T0J100G	166	Y3J25000120J100G	168	Y3J2BC201T5J100G	168	Y3L3000120000009	89	Y3M177001T0000T	127	Y3N200001T5J100T	129
Y3J1BB202T5J1007	166	Y3J25000125J1007	168	Y3J2BC20220J1007	168	Y3L3450000000008	89	Y3M177001T5000T	127	Y3N200002200000T	129
Y3J1BB202T5J100G	166	Y3J25000125J100G	168	Y3J2BC20220J100G	168	Y3L3450000000009	89	Y3M17700220000T	127	Y3N20000220J100T	129
Y3J1BC20000J1007	166	Y3J250001T0J1007	168	Y3J2BC20225J1007	168	Y3L3450120000008	89	Y3M17700225000T	127	Y3N200002250000T	129
Y3J1BC20000J100G	166	Y3J250001T0J100G	168	Y3J2BC20225J100G	168	Y3L3450120000009	89	Y3M177002T0000T	127	Y3N20000225J100T	129
Y3J1BC20120J1007	166	Y3J250001T5J1007	168	Y3J2BC202T0J1007	168	Y3L3500000000008	89	Y3M177002T5000T	127	Y3N200002T00000T	129
Y3J1BC20120J100G	166	Y3J250001T5J100G	168	Y3J2BC202T0J100G	168	Y3L3500000000009	89	Y3M1770A000000T	127	Y3N200002T0J100T	129
Y3J1BC20125J1007	166	Y3J25000220J1007	168	Y3J2BC202T5J1007	168	Y3L3500120000008	89	Y3M1770A120000T	127	Y3N200002T50000T	129
Y3J1BC20125J100G	166	Y3J25000220J100G	168	Y3J2BC202T5							





# Alphabetical list of products references used in this catalogue

References	Page	References	Page	References	Page	References	Page	References	Page	References	Page
Y3S3500D000G1008	91	Y3S56000120G1009	93	Y3S7450D120G1008	100	Y3S7770A120G1009	100	Y3SA000A000G1008	95	Y3SB406D000G1009	96
Y3S3500D000G1009	91	Y3S56000125G1008	93	Y3S7450D120G1009	100	Y3S7770A125G1008	100	Y3SA000A000G1009	95	Y3SB406D120G1008	96
Y3S3500D120G1008	91	Y3S56000125G1009	93	Y3S7450D125G1008	100	Y3S7770A125G1009	100	Y3SA000A120G1008	95	Y3SB406D120G1009	96
Y3S3500D120G1009	91	Y3S5600A000G1008	93	Y3S7450D125G1009	100	Y3S7770A2C0G1008	100	Y3SA000A120G1009	95	Y3SB406D125G1008	96
Y3S4000000G1008	92	Y3S5600A000G1009	93	Y3S7450D2C0G1008	100	Y3S7770A2C0G1009	100	Y3SA000A125G1008	95	Y3SB406D125G1009	96
Y3S4000000G1009	92	Y3S5600A120G1008	93	Y3S7450D2C0G1009	100	Y3S7770A2C5G1008	100	Y3SA000A125G1009	95	Y3SC7000000G1008	97
Y3S40000120G1008	92	Y3S5600A120G1009	93	Y3S7450D2C5G1008	100	Y3S7770A2C5G1009	100	Y3SA000D000G1008	95	Y3SC7000000G1009	97
Y3S40000120G1009	92	Y3S5600A125G1008	93	Y3S7450D2C5G1009	100	Y3S7770D0C0G1008	100	Y3SA000D000G1009	95	Y3SC7000120G1008	97
Y3S4000A000G1008	92	Y3S5600A125G1009	93	Y3S7500000G1008	100	Y3S7770D116G1009	100	Y3SA000D120G1008	95	Y3SC7000120G1009	97
Y3S4000A120G1008	92	Y3S5600D000G1009	93	Y3S75000116G1008	100	Y3S7770D116G1009	100	Y3SA000D125G1008	95	Y3SC7000125G1009	97
Y3S4000A120G1009	92	Y3S5600D120G1008	93	Y3S75000116G1009	100	Y3S7770D120G1008	100	Y3SA000D125G1009	95	Y3SC700A000G1008	97
Y3S4000D000G1008	92	Y3S5600D120G1009	93	Y3S750002C0G1008	100	Y3S7770D120G1009	100	Y3SA4500000G1008	95	Y3SC700A000G1009	97
Y3S4000D000G1009	92	Y3S5600D125G1008	93	Y3S750002C0G1009	100	Y3S7770D125G1008	100	Y3SA4500000G1009	95	Y3SC700A120G1008	97
Y3S4000D120G1008	92	Y3S5600D125G1009	93	Y3S75000125G1008	100	Y3S7770D125G1009	100	Y3SA4500120G1008	95	Y3SC700A120G1009	97
Y3S4000D120G1009	92	Y3S64060000G1008	94	Y3S75000125G1009	100	Y3S7770D2C0G1008	100	Y3SA4500120G1009	95	Y3SC700A125G1008	97
Y3S44500000G1008	92	Y3S64060000G1009	94	Y3S750002C0G1008	100	Y3S7770D2C0G1009	100	Y3SA4500125G1008	95	Y3SC700A125G1009	97
Y3S44500000G1009	92	Y3S64060120G1008	94	Y3S750002C0G1009	100	Y3S7770D2C5G1008	100	Y3SA4500125G1009	95	Y3SC700D000G1008	97
Y3S44500120G1008	92	Y3S64060120G1009	94	Y3S750002C5G1008	100	Y3S7770D2C5G1009	100	Y3SA450A000G1008	95	Y3SC700D000G1009	97
Y3S44500120G1009	92	Y3S6406A120G1008	94	Y3S750002C5G1009	100	Y3S84060000G1008	101	Y3SA450A000G1009	95	Y3SC700D120G1008	97
Y3S4450A000G1008	92	Y3S6406A120G1009	94	Y3S7500A000G1008	100	Y3S84060000G1009	101	Y3SA450A120G1008	95	Y3SC700D120G1009	97
Y3S4450A000G1009	92	Y3S6406A000G1008	94	Y3S7500A000G1009	100	Y3S8406116G1008	101	Y3SA450A120G1009	95	Y3SC700D125G1008	97
Y3S4450A120G1008	92	Y3S6406A000G1009	94	Y3S7500A116G1008	100	Y3S8406116G1009	101	Y3SA450A125G1008	95	Y3SC700D125G1009	97
Y3S4450A120G1009	92	Y3S6406A120G1008	94	Y3S7500A116G1009	100	Y3S8406120G1008	101	Y3SA450A125G1009	95	Y3SC700D125G1008	97
Y3S4450D000G1008	92	Y3S6406A120G1009	94	Y3S7500A120G1008	100	Y3S8406120G1009	101	Y3SA450D000G1008	95	Y3SC700D125G1009	97
Y3S4450D000G1009	92	Y3S6406A125G1008	94	Y3S7500A120G1009	100	Y3S8406125G1008	101	Y3SA450D000G1009	95	Y3SC700A120G1008	97
Y3S4450D120G1008	92	Y3S6406A125G1009	94	Y3S7500A125G1008	100	Y3S8406125G1009	101	Y3SA450D120G1008	95	Y3SC700A120G1009	97
Y3S4450D120G1009	92	Y3S6406D000G1008	94	Y3S7500A125G1009	100	Y3S84062C0G1008	101	Y3SA450D120G1009	95	Y3SC700A125G1008	97
Y3S4500000G1008	92	Y3S6406D000G1009	94	Y3S7500A2C0G1008	100	Y3S84062C0G1009	101	Y3SA450D125G1008	95	Y3SC700A125G1009	97
Y3S4500000G1009	92	Y3S6406D120G1008	94	Y3S7500A2C0G1009	100	Y3S84062C5G1008	101	Y3SA450D125G1009	95	Y3SC700A200G1008	97
Y3S4500000G1008	92	Y3S6406D120G1009	94	Y3S7500A2C5G1008	100	Y3S84062C5G1009	101	Y3SA450D200G1008	95	Y3SC700A200G1009	97
Y3S4500000G1009	92	Y3S6406D125G1008	94	Y3S7500A2C5G1009	100	Y3S8406A116G1008	101	Y3SA450D200G1009	95	Y3SC700A25G1008	97
Y3S4500A000G1008	92	Y3S6406D125G1009	94	Y3S7500A2C5G1009	100	Y3S8406A116G1009	101	Y3SA450D25G1008	95	Y3SC700A25G1009	97
Y3S4500A000G1009	92	Y3S7000000G1008	100	Y3S7500A2C5G1009	100	Y3S8406A116G1009	101	Y3SA450D25G1009	95	Y3SC700D000G1008	97
Y3S4500A120G1008	92	Y3S7000000G1009	100	Y3S7500D000G1008	100	Y3S8406A116G1009	101	Y3SA450D25G1009	95	Y3SC700D000G1009	97
Y3S4500A120G1009	92	Y3S70000116G1008	100	Y3S7500D000G1009	100	Y3S8406A120G1008	101	Y3SA450D25G1009	95	Y3SC700D120G1008	97
Y3S4500A120G1008	92	Y3S70000116G1009	100	Y3S7500D120G1008	100	Y3S8406A120G1009	101	Y3SA450D25G1009	95	Y3SC700D120G1009	97
Y3S4500D000G1008	92	Y3S70000120G1008	100	Y3S7500D120G1009	100	Y3S8406A125G1008	101	Y3SA5000000G1008	95	Y3SC700D120G1009	97
Y3S4500D000G1009	92	Y3S70000120G1009	100	Y3S7500D125G1008	100	Y3S8406A125G1009	101	Y3SA5000000G1009	95	Y3SC700D125G1008	97
Y3S4500D120G1008	92	Y3S70000125G1008	100	Y3S7500D125G1009	100	Y3S8406A2C0G1008	101	Y3SA5000000G1009	95	Y3SC700D125G1009	97
Y3S4500D120G1009	92	Y3S700002C0G1008	100	Y3S7500D125G1009	100	Y3S8406A2C0G1009	101	Y3SA5000000G1009	95	Y3SC700A000G1008	97
Y3S5000000G1008	93	Y3S700002C0G1009	100	Y3S7500D2C0G1008	100	Y3S8406A2C5G1008	101	Y3SA5000000G1009	95	Y3SC700A000G1009	97
Y3S5000000G1009	93	Y3S700002C5G1008	100	Y3S7500D2C0G1009	100	Y3S8406A2C5G1009	101	Y3SA5000120G1008	95	Y3SC700A120G1008	97
Y3S50000120G1008	93	Y3S700002C5G1009	100	Y3S7500D2C5G1008	100	Y3S8406A2C5G1009	101	Y3SA5000120G1009	95	Y3SC700A120G1009	97
Y3S50000120G1009	93	Y3S700002C5G1009	100	Y3S7500D2C5G1009	100	Y3S8406A2C5G1009	101	Y3SA5000125G1008	95	Y3SC700A120G1009	97
Y3S5000A000G1008	93	Y3S7000A000G1008	100	Y3S7500D2C5G1009	100	Y3S8406A2C5G1009	101	Y3SA5000125G1009	95	Y3SC700A200G1008	97
Y3S5000A000G1009	93	Y3S7000A000G1009	100	Y3S7500D2C5G1009	100	Y3S8406A2C5G1009	101	Y3SA5000125G1009	95	Y3SC700A200G1009	97
Y3S5000A120G1008	93	Y3S7000A116G1008	100	Y3S7500D2C5G1009	100	Y3S8406A2C5G1009	101	Y3SA5000200G1008	95	Y3SC700A200G1009	97
Y3S5000A120G1009	93	Y3S7000A116G1009	100	Y3S7500D2C5G1009	100	Y3S8406A2C5G1009	101	Y3SA5000200G1009	95	Y3SC700A25G1008	97
Y3S5000A125G1008	93	Y3S7000A120G1008	100	Y3S7500D2C5G1009	100	Y3S8406A2C5G1009	101	Y3SA5000200G1009	95	Y3SC700A25G1009	97
Y3S5000A125G1009	93	Y3S7000A120G1009	100	Y3S7500D2C5G1009	100	Y3S8406A2C5G1009	101	Y3SA500025G1008	95	Y3SC700A25G1009	97
Y3S5000A125G1008	93	Y3S7000A125G1008	100	Y3S7500D2C5G1009	100	Y3S8406A2C5G1009	101	Y3SA500025G1009	95	Y3SC700D000G1008	97
Y3S5000A125G1009	93	Y3S7000A125G1009	100	Y3S7500D2C5G1009	100	Y3S8406A2C5G1009	101	Y3SA500025G1009	95	Y3SC700D000G1009	97
Y3S5000D000G1008	93	Y3S7000A125G1008	100	Y3S7500D2C5G1009	100	Y3S8406A2C5G1009	101	Y3SA500025G1009	95	Y3SC700D120G1008	97
Y3S5000D000G1009	93	Y3S7000A125G1009	100	Y3S7500D2C5G1009	100	Y3S8406A2C5G1009	101	Y3SA500025G1009	95	Y3SC700D120G1009	97
Y3S5000D120G1008	93	Y3S7000A2C0G1008	100	Y3S7500D2C5G1009	100	Y3S8406A2C5G1009	101	Y3SA500025G1009	95	Y3SC700D125G1008	97
Y3S5000D120G1009	93	Y3S7000A2C0G1009	100	Y3S7500D2C5G1009	100	Y3S8406A2C5G1009	101	Y3SA500025G1009	95	Y3SC700D125G1009	97
Y3S5000D125G1008	93	Y3S7000A2C5G1008	100	Y3S7500D2C5G1009	100	Y3S8406A2C5G1009	101	Y3SA500025G1009	95	Y3SC700D125G1008	97
Y3S5000D125G1009	93	Y3S7000A2C5G1009	100	Y3S7500D2C5G1009	100	Y3S8406A2C5G1009	101	Y3SA500025G1009	95	Y3SC700D125G1009	97
Y3S54500000G1008	93	Y3S7000D000G1008	100	Y3S7500D2C5G1009	100	Y3S8406A2C5G1009	101	Y3SA500025G1009	95	Y3SC700D125G1008	97
Y3S54500000G1009	93	Y3S7000D000G1009	100	Y3S7500D2C5G1009	100	Y3S8406A2C5G1009	101	Y3SA500025G1009	95	Y3SC700D125G1009	97
Y3S54500120G1008	93	Y3S7000D116G1008	100	Y3S7500D2C5G1009	100	Y3S8406A2C5G1009	101	Y3SA500025G1009	95	Y3SC700D125G1008	97
Y3S54500120G1009	93	Y3S7000D116G1009	100	Y3S7500D2C5G1009	100	Y3S8406A2C5G1009	101	Y3SA500025G1009	95	Y3SC700D125G1009	97
Y3S5450A000G1008	93	Y3S7000D116G1009	100	Y3S7500D2C5G1009	100	Y3S8406A2C5G1009	101	Y3SA500025G1009	95	Y3SC700D125G1008	97
Y3S5450A000G1009	93	Y3S7000D120G1008	100	Y3S7500D2C5G1009	100	Y3S8406A2C5G1009	101	Y3SA500025G1009	95	Y3SC700D125G1009	97
Y3S5450A120G1008	93	Y3S7000D120G1009	100	Y3S7500D2C5G1009	100	Y3S8406A2C5G1009	101	Y3SA500025G1009	95	Y3SC700D125G1008	97
Y3S5450A120G1009	93	Y3S7000D125G1008	100	Y3S7500D2C5G1009	100	Y3S8406A2C5G1009	101	Y3SA500025G1009	95	Y3SC700D125G1009	97
Y3S5450A125G1008	93	Y3S7000D125G1009	100	Y3S7500D2C5G1009	100	Y3S8406A2C5G1009	101	Y3SA500025G1009	95	Y3SC700D125G1008	97
Y3S5450D000G1008	93	Y3S7000D125G1009	100	Y3S7500D2C5G1009	100	Y3S8406A2C5G1009	101	Y3SA500025G1009	95	Y3SC700D125G1009	97
Y3S5450D000G1009	93	Y3S745000116G1008	100	Y3S7500D2C5G1009	100	Y3S8406A2C5G1009	101	Y3SA500025G1009	95	Y3SC700D125G1008	97
Y3S5450D120G1008	93	Y3S74500116G1009	100	Y3S7500D2C5G1009	100	Y3S8406A2C5G1009	101	Y3SA500025G1009	95	Y3SC700D125G1009	97
Y3S5450D120G1009	93	Y3S74500120G1008	100	Y3S7500D2C5G1009	100	Y3S8406A2C5G100					



# JPC

## New products 2015

30





Thermostat with plastic enclosure, **pigtail bulb**  
 Thermostat with **extra flat** plastic enclosure, with pilot light, ambient or distant temperature measurement, 1 to 3 cable glands  
 Thermostat with **extra flat** plastic enclosure, with pilot light and **rod temperature sensor**  
 Combination of thermostat and manual reset limiter, plastic enclosure, with pilot light, rod or capillary temperature sensor  
 Dia. 10 mm cartridge thermostat with 1/2" or M14x1.5 fitting, calibration from 50 to 150°C  
 Miniature temperature limiter, for explosive gas atmospheres (ATEX and IECEx), calibration from 40 to 150°C  
 Over-molded disc thermostat on heat tracing cable  
 Rotary switch for thermostat shaft.  
 Bulb and capillary thermostat, range 60-500°C  
 Epoxy potted **waterproof manual reset** disc thermostat  
 Wood stove damper bulb and capillary thermostat  
**Elevated connection blocks** 2 x 2.5mm<sup>2</sup>, 3 x 2.5mm<sup>2</sup>, 5 x 2.5mm<sup>2</sup> and 6 x 2.5mm<sup>2</sup>  
 Various enclosures for immersion heaters  
 Heat tracing cable **end boots** with **silicone gel filling**  
 Flexible **silicone enclosures** thermostats and sensors of **heating pads**

The professional solution: **an extended, rational and consistent range of products**

Technical catalogue for R&D department

**JPC** JPC sas, 2 voie Gallo Romaine, ZAC de la Bonne Rencontre, 77860 Quincy Voisins, France  
 Tel: +33(0)1 60048644 Fax: +33(0)1 60048444 E-Mail: info@jpcfrance.fr Web: www.jpcfrance.fr



# JPC

## New products 2016

31





Thermostats for incorporation, **400 and 500°C**,  
 IPx4, IPx5, **IPx6** thermostats,  
**Electronic** thermostats and limiters,  
**Corrosive baths** thermostats, housings and sensors,  
**15A 250V** Flow switches,  
**900°C** Ceramic connection blocks,  
 Breakable **glass bulb** fire detection link

The professional solution: **an extended, rational and consistent range of products**

Technical catalogue for R&D department

**JPC** JPC sas, 2 voie Gallo Romaine, ZAC de la Bonne Rencontre, 77860 Quincy Voisins, France  
 Tel: +33(0)1 60048644 Fax: +33(0)1 60048444 E-Mail: info@jpcfrance.fr Web: www.jpcfrance.fr



# JPC

## 2017-2018 New products

32





Flow switch, 1/4" male, full stainless steel, with 15A 230V rating  
 Flow switch, 3/4" female, plastic body, fixed setting, for large series  
 Electronic wall thermostat, IP69K ingress protection  
 Electronic controller with digital display, wall mounting, IP69K ingress protection  
 300 DaN and 150 DaN glass bulb fire detection links  
 Eutectic alloy miniature fire detection links (robotic assembly)  
 Heat tracing connection boxes for 2 and 3 ways, with and without thermostat  
 Two directions tilt switch, 16A 250V, for electric heaters  
 Level switch with built-in 16A 230V relay and indicator lamp  
 Miniature terminal blocks in PA66, 3, 4, 6, 8 poles 2.5mm<sup>2</sup>.  
 3 and 5 poles 2.5mm<sup>2</sup> round ceramic terminal blocks  
 M16 ceramic cable entry for cables up to 10mm diameter  
 M24 cable gland in PA66.  
 Titanium pockets for immersion heaters and sensors

The professional solution: **an extended, rational and consistent range of products**

Technical catalogue for R&D department

**JPC** JPC sas, 2 voie Gallo Romaine, ZAC de la Bonne Rencontre, 77860 Quincy Voisins, France  
 Tel: +33(0)1 60048644 Fax: +33(0)1 60048444 E-Mail: info@jpcfrance.fr Web: www.jpcfrance.fr

# Other catalogues



**JPC** 1

### ELECTROMECHANICAL THERMOSTATS

for incorporation

These thermostats are also available incorporated inside various boxes, housing and cabinets. See Y3 to Y8 catalogues. Explosion proof versions are described on Y9 catalogue.

The professional solution: an extended, rational, and consistent range of products.

Technical catalogue for R&D department

JPC sas, 2 voie Gallo Romaine, ZAC de la Bonne Rencontre, 77860 Quincy Voisins, France. Tel: +33(0)1 60046644 Fax: +33(0)1 60048444 E-Mail: info@jpcfrance.fr Web: www.jpcfrance.fr

**JPC** 2

### THERMOSTAT WITH INGRESS PROTECTION HOUSINGS

Connection boxes for heating elements, Electrical junction boxes Types Y9, Y2, Y3, Y4, Y5

For industrial and high end applications: See our catalogue Y6, Y7, Y8. For explosion proof applications: See our catalogue Y9.

For incorporation see our "Thermostats for incorporation" catalogue

The professional solution: an extended, rational, and consistent range of products.

Technical catalogue for R&D department

JPC sas, 2 voie Gallo Romaine, ZAC de la Bonne Rencontre, 77860 Quincy Voisins, France. Tel: +33(0)1 60046644 Fax: +33(0)1 60048444 E-Mail: info@jpcfrance.fr Web: www.jpcfrance.fr

**JPC** 3

### INDUSTRIAL ELECTRONIC AND THERMOSTAT CONTROLS

electronic controllers, thermostatic control boxes, sub-assemblies and accessories for temperature control in electro-thermal equipment V6-V7-Y8 series

Heat tracing, Immersion heaters, Air heaters, Flexible surface heating elements, Fan

The professional solution: an extended, rational, and consistent range of products.

Technical catalogue for R&D department

JPC sas, 2 voie Gallo Romaine, ZAC de la Bonne Rencontre, 77860 Quincy Voisins, France. Tel: +33(0)1 60046644 Fax: +33(0)1 60048444 E-Mail: info@jpcfrance.fr Web: www.jpcfrance.fr

**JPC** 4

### EXPLOSION PROOF THERMOSTATS

Types Y9

For industrial and high end applications in non-hazardous area: See our catalogue Y6, Y7, Y8. For standard applications with ingress protection housing, in non-hazardous area: see our catalogue Y3. For incorporation in non-hazardous area see our "Thermostats for incorporation" catalogue.

The professional solution: an extended, rational, and consistent range of products.

Technical catalogue for R&D department

JPC sas, 2 voie Gallo Romaine, ZAC de la Bonne Rencontre, 77860 Quincy Voisins, France. Tel: +33(0)1 60046644 Fax: +33(0)1 60048444 E-Mail: info@jpcfrance.fr Web: www.jpcfrance.fr

**JPC** 5

### PRESSURE SWITCHES

Air switches  
Positive Pressure switches  
Vacuum pressure switches  
Differential pressure switches

Elastomer membrane types, medium pressure range (20 to 4500 mbar)

The professional solution: an extended, rational, and consistent range of products.

Technical catalogue for R&D department

JPC sas, 2 voie Gallo Romaine, ZAC de la Bonne Rencontre, 77860 Quincy Voisins, France. Tel: +33(0)1 60046644 Fax: +33(0)1 60048444 E-Mail: info@jpcfrance.fr Web: www.jpcfrance.fr

**JPC** 6

### FLOW SWITCHES AND COMBINATION CONTROLS

The professional solution: an extended, rational, and consistent range of products.

Technical catalogue for R&D department

JPC sas, 2 voie Gallo Romaine, ZAC de la Bonne Rencontre, 77860 Quincy Voisins, France. Tel: +33(0)1 60046644 Fax: +33(0)1 60048444 E-Mail: info@jpcfrance.fr Web: www.jpcfrance.fr

**JPC** 7

### FLOAT LEVEL SWITCHES

Vertical and horizontal models  
For OEM applications

The professional solution: an extended, rational, and consistent range of products.

Technical catalogue for R&D department

JPC sas, 2 voie Gallo Romaine, ZAC de la Bonne Rencontre, 77860 Quincy Voisins, France. Tel: +33(0)1 60046644 Fax: +33(0)1 60048444 E-Mail: info@jpcfrance.fr Web: www.jpcfrance.fr

**JPC** 8

### HUMIDISTATS

Electronic humidity controls

The professional solution: an extended, rational, and consistent range of products.

Technical catalogue for R&D department

JPC sas, 2 voie Gallo Romaine, ZAC de la Bonne Rencontre, 77860 Quincy Voisins, France. Tel: +33(0)1 60046644 Fax: +33(0)1 60048444 E-Mail: info@jpcfrance.fr Web: www.jpcfrance.fr

**JPC** 9

### FIRE DETECTION FUSIBLE LINKS

A fusible link is a mechanical part that breaks at a preset temperature; they are used in fire detection systems to open or close door, dampers, vents etc... if ambient temperature rise upon a certain value.

The professional solution: an extended, rational, and consistent range of products.

Technical catalogue for R&D department

JPC sas, 2 voie Gallo Romaine, ZAC de la Bonne Rencontre, 77860 Quincy Voisins, France. Tel: +33(0)1 60046644 Fax: +33(0)1 60048444 E-Mail: info@jpcfrance.fr Web: www.jpcfrance.fr

**JPC** 10

### CERAMIC CONNECTION BLOCKS and Special connectors

The professional solution: an extended, rational, and consistent range of products.

Technical catalogue for R&D department

JPC sas, 2 voie Gallo Romaine, ZAC de la Bonne Rencontre, 77860 Quincy Voisins, France. Tel: +33(0)1 60046644 Fax: +33(0)1 60048444 E-Mail: info@jpcfrance.fr Web: www.jpcfrance.fr

**JPC** 11

### Enclosures and accessories for immersion heaters and temperature sensors

- PA66, PP, PVDF, stainless steel enclosures
- Hot forged brass fittings, deep drawn stainless steel fittings
- Stainless steel, titanium pockets and probes
- PA66 connection blocks

The professional solution: an extended, rational, and consistent range of products.

Technical catalogue for R & D department

JPC sas, 2 voie Gallo Romaine, ZAC de la Bonne Rencontre, 77860 Quincy Voisins, France. Tel: +33(0)1 60046644 Fax: +33(0)1 60048444 E-Mail: info@jpcfrance.fr Web: www.jpcfrance.fr

**JPC** 12

### Heat tracing accessories

- Adjustable or fixed setting anti-freeze waterproof thermostats
- Waterproof or DIN rail mounting electronic thermostats
- Connection boxes and control boxes
- Heat tracing cables termination by silicone boots, gel filled boots, and over-molding
- Heating wires net mounting strips

The professional solution: an extended, rational, and consistent range of products.

Technical catalogue for R & D department

JPC sas, 2 voie Gallo Romaine, ZAC de la Bonne Rencontre, 77860 Quincy Voisins, France. Tel: +33(0)1 60046644 Fax: +33(0)1 60048444 E-Mail: info@jpcfrance.fr Web: www.jpcfrance.fr



JPC sas, 2 voie Gallo Romaine, ZAC de la Bonne Rencontre, 77860 Quincy Voisins, France  
Tel: +33(0)1 60046644 Fax: +33(0)1 60048444 E-Mail: info@jpcfrance.fr Web: www.jpcfrance.fr





# ✓ Enclosures and accessories for immersion heaters and temperature sensors