

# Boîtier moyen pour thermoplongeur ou capteur de température. En acier inoxydable AISI 304 ou AISI 316

En raison de l'évolution technique constante de nos produits, les plans, dessins, photos et caractéristiques repris dans les pages techniques sont communiqués sans engagement et peuvent être modifiés sans préavis

Taille(mm)	Volume(cm <sup>3</sup> )	Matière	Degrés de protection		Modèle
<b>105 × 105 × 102</b>	<b>757</b>	<b>acier inoxydable</b>	<b>IP69K</b>	<b>IK7</b>	<b>Y3S5</b>

Utilisable pour
<input type="checkbox"/> Capteur de température
<input checked="" type="checkbox"/> Thermoplongeur
<input checked="" type="checkbox"/> Résistance à ailettes
<input checked="" type="checkbox"/> Thermostat
<input type="checkbox"/> Détecteur de niveau
<input checked="" type="checkbox"/> Carte électronique

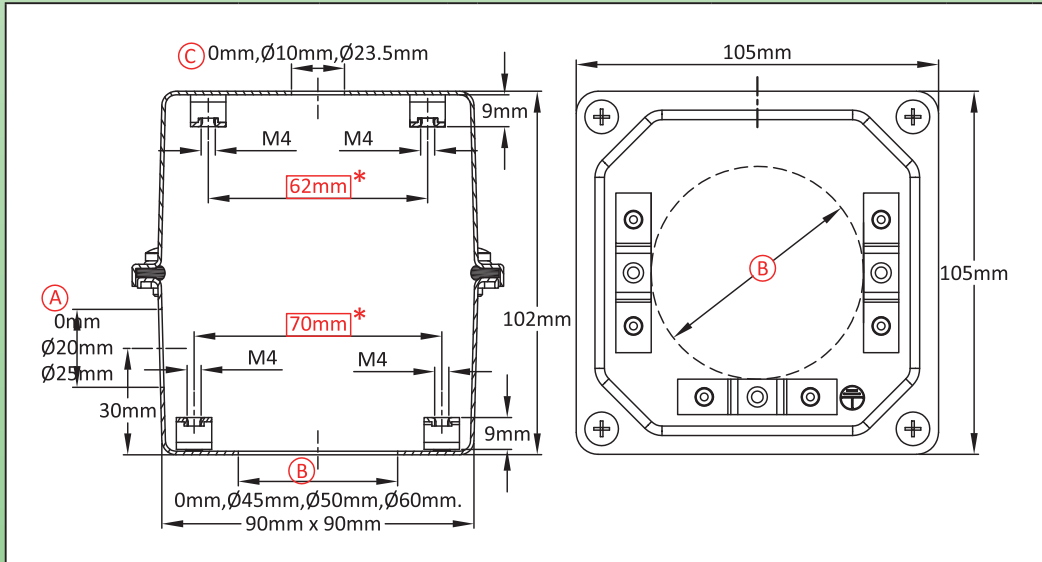
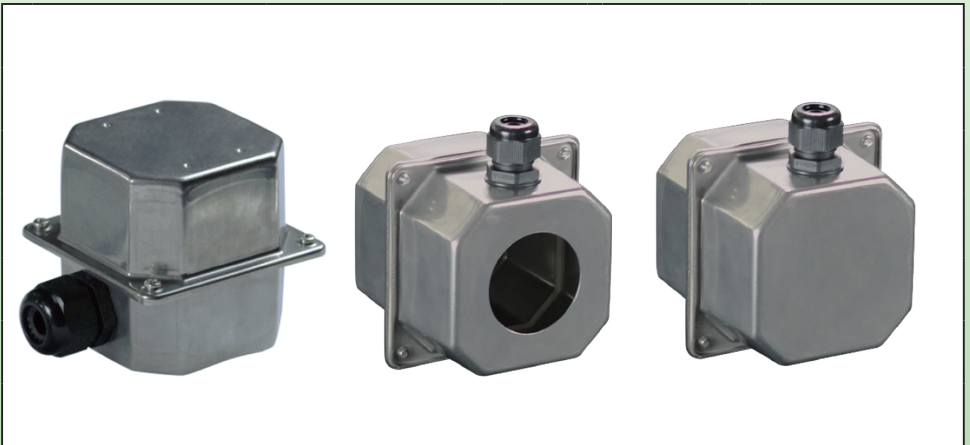

### Liens

Page (.pdf)

Plan 2D (.dwg)

Plan 3D (.stp)

### Références principales

(A) (mm)	(B) (mm)	(C) (mm)	304	316	(A) (mm)	(B) (mm)	(C) (mm)	304	316	(A) (mm)	(B) (mm)	(C) (mm)	304	316
0	0	0	Y3S5000000G1008	Y3S5000000G1009	20	0	0	Y3S50000120G1008	Y3S50000120G1009	25	0	0	Y3S50000125G1008	Y3S50000125G1009
0	0	10	Y3S5000A000G1008	Y3S5000A000G1009	20	0	10	Y3S5000A120G1008	Y3S5000A120G1009	25	0	10	Y3S5000A125G1008	Y3S5000A125G1009
0	0	23.5	Y3S5000D000G1008	Y3S5000D000G1009	20	0	23.5	Y3S5000D120G1008	Y3S5000D120G1009	25	0	23.5	Y3S5000D125G1008	Y3S5000D125G1009
0	45	0	Y3S5450000G1008	Y3S5450000G1009	20	45	0	Y3S54500120G1008	Y3S54500120G1009	25	45	0	Y3S54500125G1008	Y3S54500125G1009
0	45	10	Y3S5450A000G1008	Y3S5450A000G1009	20	45	10	Y3S5450A120G1008	Y3S5450A120G1009	25	45	10	Y3S5450A125G1008	Y3S5450A125G1009
0	45	23.5	Y3S5450D000G1008	Y3S5450D000G1009	20	45	23.5	Y3S5450D120G1008	Y3S5450D120G1009	25	45	23.5	Y3S5450D125G1008	Y3S5450D125G1009
0	50	0	Y3S5500000G1008	Y3S5500000G1009	20	50	0	Y3S55000120G1008	Y3S55000120G1009	25	50	0	Y3S55000125G1008	Y3S55000125G1009
0	50	10	Y3S5500A000G1008	Y3S5500A000G1009	20	50	10	Y3S5500A120G1008	Y3S5500A120G1009	25	50	10	Y3S5500A125G1008	Y3S5500A125G1009
0	50	23.5	Y3S5500D000G1008	Y3S5500D000G1009	20	50	23.5	Y3S5500D120G1008	Y3S5500D120G1009	25	50	23.5	Y3S5500D125G1008	Y3S5500D125G1009
0	60	0	Y3S5600000G1008	Y3S5600000G1009	20	60	0	Y3S56000120G1008	Y3S56000120G1009	25	60	0	Y3S56000125G1008	Y3S56000125G1009
0	60	10	Y3S5600A000G1008	Y3S5600A000G1009	20	60	10	Y3S5600A120G1008	Y3S5600A120G1009	25	60	10	Y3S5600A125G1008	Y3S5600A125G1009
0	60	23.5	Y3S5600D000G1008	Y3S5600D000G1009	20	60	23.5	Y3S5600D120G1008	Y3S5600D120G1009	25	60	23.5	Y3S5600D125G1008	Y3S5600D125G1009

Presse étoupe non inclus dans les références ci-dessus. Nous consulter si vous les souhaitez.  
Les dimensions encadrées en rouge sont celles prévues pour le montage des accessoires.